

NOTICE TO BIDDERS

NOTICE IS HEREBY GIVEN, that the Undersigned, on behalf of the Essex County Board of Supervisors, will accept sealed bids at the Office of the Purchasing Agent until 2:00 P.M. on March 27, 2019 for CAMPSITE ROAD OVER THE HUDSON RIVER BRIDGE REPLACEMENT.

The bids shall be opened publicly and read aloud on March 27, 2019 at 2:00 P.M. at the Office of the Purchasing Agent, 7551 Court Street, Elizabethtown, New York 12932.

Please contact the Purchasing Office at (518) 873-3330 for additional information concerning the bidding. Plans, specifications, standard proposals and drawings for the proposed work may be obtained at the above address or on the County's website at: <https://www.co.essex.ny.us/bidders/publicbids.aspx>.

All bids submitted in response to this notice shall be marked "SEALED BID – CAMPSITE ROAD BRIDGE REPLACEMENT" clearly on the outside of the envelope with the bidder's name and address.

Essex County affirmatively states that in regard to any contract entered into pursuant to these instructions, without regard to race, color, sex, religion, age, national origin, disability, sexual preference or Vietnam Era veteran status, disadvantaged and minority or women-owned business enterprises will be afforded equal opportunity to submit bids in response hereto.

Dated: March 4, 2019

Linda M. Wolf, CPA
Purchasing Agent
Essex County Government Center
7551 Court Street – PO Box 217
Elizabethtown, New York 12932
(518) 873-3332

PROJECT MANUAL

for

Campsite Road over the Hudson River

Bridge Replacement

BIN 3302040

PIN 1760.68

D#:035560



ESSEX COUNTY DEPARTMENT OF PUBLIC WORKS

8053 U.S. Route 9

ELIZABETHTOWN, NEW YORK 12932

TELEPHONE: 518-873-6326

CHRIS GARROW, SUPERINTENDENT OF PUBLIC WORKS

March 2019

PREPARED BY:



Creighton Manning Engineering, LLP

2 Winners Circle

Albany, New York 12205

Ph: (518) 446-0396

TABLE OF CONTENTS

I. GENERAL BID INFORMATION

A. Notice to Bidders	I-1
B. Instruction to Bidders.....	I-3
1.) General Note	I-3
2.) Definition of Terms.....	I-3
3.) Qualification of Bidders.....	I-5
4.) Examination of Contract Documents and Site.....	I-5
5.) Availability of Lands for Work.....	I-7
6.) Interpretations and Addenda	I-7
7.) Bid Security	I-7
8.) Contract Times.....	I-7
9.) Liquidated Damages	I-8
10.) Substitute and or “Equal Items”.....	I-8
11.) Subcontractors, Suppliers and Others	I-8
12.) Bid Form	I-8
13.) Disqualification.....	I-9
14.) Submission of Bids	I-10
15.) Modification and Withdrawal of Bids	I-10
16.) Opening of Bids	I-10
17.) Bids to Remain Subject to Acceptances	I-10
18.) Award of Contract.....	I-10
19.) Contract Security	I-11
20.) Signing of Agreement.....	I-11
21.) Sales and Use Taxes.....	I-11
22.) Retainage	I-11
23.) Laws and Regulations	I-11
24.) Coordination with Others.....	I-12
25.) Non Collusive Bidding Certificate.....	I-12
26.) Basis of Award.....	I-12
27.) Notice of Special Conditions	I-12
28.) Control of Work.....	I-12
29.) Control of Materials.....	I-13
30.) Insurance Requirements.....	I-13
31.) Payment Procedures.....	I-19
32.) Official Copies of this Bid.....	I-19

II. BID DOCUMENTS (Return with Bid)

1.) Title Page	II-1
2.) Bid Form	II-3
3.) Resolution of Board of Directors.....	II-7
4.) Non-Interruption of Work Agreement.....	II-9
5.) Bid	II-11
6.) Bid Security (Bond).....	II-34
7.) Acknowledgement of Receipt of Addenda.....	II-36

8.) Requirements Regarding Lobbying Activities on Federal Aid Contracts	II-38
9.) Non-Collusive Bidding Certification.....	II-42
10.) Disadvantaged Business Enterprise Utilization Goals	II-48
11.) Certification for Federal Aid Contracts	II-50
12.) Iran Divestment Act.....	II-52
13.) Certification of Experience	II-53
14.) Essex County Vendor Responsibility Questionnaire	
15.) W-9 Form	

III. AGREEMENT

Agreement	III-1
Certification of Attorney.....	III-7
Affidavit of Workmen’s Compensations	III-9
Construction & Material Payment Bonds & Guarantees.....	III-11
Labor & Materials Payment Bond	III-13
Insurance Certificate	III-15
NYS Uniform Contracting Questionnaire	III-16
Addendum A & B	III-16
Appendix A – Standard Clauses for New York State Contracts (7 Pages)	

IV. SPECIAL NOTES

Special Notes Listing	IV-1
-----------------------------	------

V. SPECIFICATIONS

A. Specifications.....	V-1
B. Definitions.....	V-1
C. Special Specifications	V-3

VI. FEDERAL & STATE LABOR REQUIREMENTS FOR PUBLIC WORK

- A. Federal Rates
- B. New York State Prevailing Wage Rates

VII. REQUIRED CONTRACT PROVISIONS FOR FEDERAL AID PROJECTS

A. Equal Opportunity Requirements for Federal Aid Project	VII-2
B. Goals for Minority Participation in the Construction Industry.....	VII-3
C. Required Contract Provisions for Federal Aid Projects.....	VII-4

VIII. ESSEX COUNTY DOCUMENTS

- A. Essex County Supplementary Terms and Conditions
- B. Appendix D – Standard Clauses for Essex County Contracts
- C. Essex County DPW Change Order
- D. Index to Information for Bidders

- E. Index to General Clauses
- F. Index to Standard Special Clauses Road and Bridge Construction Contracts
- G. Non-Bidder Response

APPENDICES

- Appendix A – Utility Work Agreements
- Appendix B – Right-Of-Way Clearance Certificate
- Appendix C – Environmental Permits
- Appendix D – Soil Boring Logs

I. GENERAL BID INFORMATION

A. NOTICE TO BIDDERS

Notice is hereby given the Essex County will accept sealed bids for:

**Campsite Road over the Hudson River – Bridge Replacement; B.I.N. 3302040; PIN 1760.68,
Town of Newcomb, Essex County, New York (BIN 3302040)**

Contract will be awarded based upon the lowest qualified bid.

Contract Documents, including Invitation to Bidders, Instructions to Bidders, Wage Rates, Bid Documents, Agreement, Special Notes, Specifications, Contract Drawings and any Addenda, may be examined at no expense at the office of Creighton Manning Engineering, 2 Winners Circle, Albany, NY 12205 or at the Office of the Essex County Purchasing Agent, 7551 Court Street, Elizabethtown, NY 12932.

Bids documents may be obtained for no charge online from Essex County Bids/RFPs website.

<https://www.co.essex.ny.us/bidders/publicbids.aspx>

Each bid must be accompanied by security in an amount not less than five percent (5%) of the amount of the bid in the form and subject to the conditions provided in the Instructions to Bidders. No bidder may withdraw his bid within forty-five (45) days after the actual date of opening thereof.

The attention of Bidders is particularly called to the requirements as to conditions of employment to be observed and minimum wage rates to be paid under this Contract.

Bids to be considered must be received in a sealed envelope at the office of Linda Wolf, Purchasing Agent, Essex County Purchasing Department, 7551 Court St, Elizabethtown, NY 12932 by **2:00 PM, local time, on March 27, 2019** at which time and place they will be publicly opened and read aloud. Bids received after the above noted time will not be accepted. All sealed envelopes should be clearly labeled "**BID FOR CAMPSITE ROAD OVER THE HUDSON RIVER – BRIDGE REPLACEMENT.**" The sealed bids shall include the completed Bid Form, Non-Collusive Bidding Certification (as required by chapter 956 of the Laws of New York State), and Bid Bond.

The Bidder to whom the Contract is awarded will be required to furnish Performance, Payment and Guarantee Bonds from an acceptable Surety Company for an amount not less than 100% of the accepted bid.

Essex County reserves the right to consider the bids for forty-five (45) days after receipt before awarding any Contract, and to waive any informalities in, and to reject, any and all bids or to accept the one that in its judgment will be for the best interest of the County. All bids are subject to final review and approval by the Essex County Purchasing Agent before any award of contract may be made. Receipt of bids by the County shall not be construed as authority to bind the County.

Owners Contact

Linda Wolf, Purchasing Agent
Essex County Purchasing Department
Phone: (518) 873-3332
Email: lwolf@co.essex.ny.us

Engineers Contact

Alex Brown, PE
Creighton Manning Engineering, LLP
Phone: (518) 446-0396
Email: abrown@cmellp.com

No questions or inquiries regarding this bid will be accepted within three (3) business days prior to the bid opening.

(This page intentionally left blank)

B. INSTRUCTION TO BIDDERS

1. General Note

In general, the New York State Department of Transportation Office of Engineering *Standard Specifications* shall apply, except where modified in these specifications. The NYSDOT Standard Specifications are available at <https://www.dot.ny.gov/main/business-center/engineering/specifications>. The CONTRACTOR should note that the Project Plans are dimensioned in US Customary Units only, and that all Payment Items will be measured and paid in standard US Customary Units. Further direction is provided under SPECIAL NOTES. Where reference is made to New York State, State Department of Transportation, Commissioner, etc., the appropriate Essex County Department, Bureau or Official shall be substituted.

The Essex County Purchasing Agent or its authorized representative shall make the final interpretations of any irregularities, ambiguities or questions arising out of these specifications and the New York State Department of Transportation *Standard Specifications* used on this project.

Under this contract the New York State Department of Transportation Office of Engineering *Standard Specifications* and addenda are amended as follows:

References to the County's representative and County personnel shall hereinafter be made as the "Engineer".

2. Definition of Terms

Under Section 101-02 Definition and Terms

- 2.1 Page 22, Chief Engineer
Delete the stated definition. This term where used in the specifications or contract documents shall mean "Essex County" or its authorized representative.
- 2.2 Page 22, Commissioner
Delete the stated definition. This term where used in the specifications or contract documents shall mean "Essex County".
- 2.3 Page 22, Comptroller
Delete the stated definition. This term where used in the specifications or contract documents shall mean "Essex County".
- 2.4 Page 24, Department
Delete the stated definition. This term where used in the specifications or contract documents shall mean "Essex County" and may also be used to mean "Essex County" or its authorized representative except as noted.
- 2.5 Page 24, Departmental Geotechnical Engineer
Delete the stated definition. "Essex County " or its authorized representative shall be responsible and is in charge of all engineering and construction work on this contract except as noted.
- 2.6 Page 24, Departmental Engineering Geologist
Delete the stated definition and substitute the same definition as above for Note 5.

- 2.7 Page 24, Engineer or Engineer-In-Charge
Delete the words "Department of Transportation" and substitute "Essex County Department of Public Works ". Also delete the words "Regional Director" and substitute "Essex County Department of Public Works Superintendent" except as noted.
- 2.8 Page 25, Final Agreement
Delete "State of New York, Department of Transportation" and substitute "Essex County".
- 2.9 Page 25, Inspector
Delete "The Department of Transportation" and substitute "The authorized representative of the "Essex County Department of Public Works" except as noted.
- 2.10 Page 26, Materials Bureau
Delete the word "Bureau" and the stated definition and substitute "Essex County Department of Public Works has the responsibility in the quality assurance for materials to be used on the contract except as noted".
- 2.11 Page 28, Regional Director
Delete the stated definition and substitute: "When used, means the Essex County Department of Public Works Superintendent".
- 2.12 Page 29 State
Delete the stated definition and substitute: "When used, means the "Essex County Department of Public Works, represented by the "Essex County Department of Public Works Superintendent" except as noted.

Under Section 102 - Bidding Requirements and Conditions

- 2.13 Page 30, Subsection 102-01, Location of Regional Offices
Delete entire subsection -- not applicable.
- 2.14 Page 35, Subsection 102-06, Bid Deposit
Delete from the 2nd and 3rd lines the words "State of New York," and substitute "Essex County".

Under subsequent sections of this document:

- A. The term "Owner" means the **Essex County**, and being the governmental unit whose name is given on the Contract Document cover.
- B. The term "Engineer" means **Creighton Manning Engineering, LLP** and or any duly authorized representative of this firm or the **Essex County Department of Public Works**.
- C. The term "Bidder" shall mean any party or parties submitting in proper form a Proposal to perform the work specified hereinafter.
- D. The term "Contractor" shall mean the successful Bidder selected by the Owner to contract to perform the work - or their heirs, executors, successors, administrators or assigns.

- E. The term "Work" is used to designate the work, equipment, materials and things required to be done, furnished or performed by the Contractor under the Specifications attached hereafter.
- F. Where the NYSDOT is mentioned in any capacity (including, but not limited to, Department, State, Commissioner of Transportation, DOT, DCES or Directors(s) of its subdivisions) as an approving authority with regard to materials, fabrication, inspections or other approvals, the approving authority shall be changed to the Owner. This change shall be made in all of the documents relating to this contract.

3. Qualifications of Bidders

To demonstrate qualifications to perform the Work, each BIDDER must be prepared to submit within five days after Bid opening upon Owner's request detailed written evidence such as financial data, previous experience present commitments and other such data as may be called for below (or in the Supplementary Instructions). Each Bid must contain evidence of BIDDER's qualification to do business in the state where the Project is located or covenant to obtain such qualification prior to award of the contract.

4. Examination of Contract Documents and Site

- 4.1 It is the responsibility of each BIDDER before submitting a Bid:
 - 4.1.2 To examine thoroughly the Contract Documents and other related data identified in the bidding Documents (including "technical" data referred to below);
 - 4.1.3 To visit the site to become familiar with and satisfy BIDDER as to the general, local and site conditions that may affect cost, progress, performance, or furnishing of the Work;
 - 4.1.4. To consider federal, state, and local Laws and Regulations that may affect cost, progress, performance or furnishing of the Work;
 - 4.1.5. To promptly notify Engineer of all conflicts, errors, ambiguities or discrepancies which BIDDER has discovered in or between the Contract documents and such other related documents.
- 4.2 Reference is made to the Supplemental Information Available to Bidders, Special Notes and Appendices for identification of:
 - 4.2.1 Those reports of explorations and tests of subsurface conditions at or contiguous to the site which have been utilized by Engineer in preparation of the Contract Documents. BIDDER may rely upon the general accuracy of the "technical data" contained in such reports but not upon other data, interpretations, opinions or information contained in such reports or otherwise relating to the subsurface conditions at the site, nor upon the completeness thereof for the purposes of bidding or construction.
 - 4.2.2 Those drawings of physical conditions in or relating to existing surface and subsurface structures (except Underground Facilities) which are at or contiguous to the site that have been utilized by Engineer in preparation of the Contract Documents. BIDDER may rely upon the general accuracy of the "technical data" contained in such drawings but not upon other data, interpretations, opinions, or information shown or indicated in such drawings

or otherwise relating to such structures, not upon the completeness thereof for the purposes of bidding or construction.

Copies of such reports and drawings will be made available by Owner to any BIDDER on request. Those reports and drawings are not part of the Contract Documents, but the “technical data” contained therein upon which BIDDER is entitled to rely upon. BIDDER is responsible for any interpretation or conclusion drawn from any “technical data” or any such data, interpretations, opinions, or information.

- 4.3 Information and data shown or indicated in the Contract Documents with respect to existing Underground Facilities at or contiguous to the site is based upon information and data furnished to Owner and Engineer by Owners of such Underground Facilities or others, and the Owner and Engineer do not assume responsibility for the accuracy or completeness thereof unless it is expressly provided otherwise.
- 4.4 Provisions concerning responsibilities for the adequacy of data furnished to prospective BIDDERS with respect to subsurface conditions, other physical conditions and Underground Facilities, and possible changes in the Contract Documents due to differing or unanticipated conditions appears in Paragraphs 4.2 and 4.3 of the Instruction to Bidders.
- 4.5 Before submitting a Bid each BIDDER will be responsible to obtain such additional or supplementary examinations, investigations, explorations, tests, studies, and data concerning conditions (surface, subsurface, and Underground Facilities) at or contiguous to the site or otherwise, which may affect cost, progress, performance or furnishing of the Work or which relate to any aspect of the means, methods, techniques, sequences or procedures of construction to be employed by BIDDER and safety precautions and programs incident thereto or performing and furnishing the Work in accordance with the time, price, and other terms and conditions of the Contract Documents.
- 4.6 On request, OWNER will provide each BIDDER access to the site to conduct such examinations, investigations, explorations, tests, and studies as each BIDDER deems necessary for submission of a Bid. BIDDER must fill all holes and clean up and restore the site to its former conditions upon completion of such explorations, investigations, tests, and studies.
- 4.7 Reference is made to the Special Notes for the identification of the general nature of work that is to be performed at the site by Owner or others (such as utilities and other prime contractors) that relates to the work for which a Bid is to be submitted. On request, OWNER will provide to each BIDDER for examination access to or copies of Contract Documents (other than portions thereof related to price) for such work.
- 4.8 The submission of a Bid will constitute an incontrovertible representation by BIDDER that BIDDER has complied with every requirement of this Article 4, that without exception of the Bid is premised upon performing and furnishing the Work required by the Contract Documents and applying the specific means, methods, techniques, sequences, or procedures for construction (if any) that may be shown or indicated or expressly required by the Contract Documents, the BIDDER has given Engineer written notice of all conflicts, errors, ambiguities and discrepancies that BIDDER has discovered in the Contract Documents are generally sufficient to indicate and convey understanding of all terms and conditions for performing and furnishing the Work.

- 4.9 The provisions of 1-4.1 through 4.8, inclusive, do not apply to Asbestos, Polychlorinated biphenyls (PCBs), Petroleum, Hazardous Waste, or Radioactive Material covered by Paragraph 4.5 of the Instruction to Bidders.

5 Availability of Lands for Work, etc.

The lands upon which the Work is to be performed, rights-of-way and easements for access thereto and other lands designated for use by Contractor in performing the Work are identified in the Contract Documents. All additional land and access thereto required for temporary construction facilities, construction equipment, or storage of materials and equipment to be incorporated in the Work are to be obtained and paid for by CONTRACTOR. Easements for permanent structures or permanent changes in existing facilities are to be obtained and paid for by OWNER unless otherwise provided in the Contract Documents.

6 Interpretations and Addenda.

- 6.1 All questions about the meaning or intent of the bidding Documents are to be directed to Engineer. Interpretations or clarifications considered necessary by Engineer in response to such questions will be issued by Addenda mailed or delivered to all parties recorded by Engineer as having received the Bidding Documents. Questions received less than five (5) business days prior to the date for opening of Bids may not be answered. Only questions answered by formal written Addenda will be binding. Oral and other interpretations or clarifications will be without legal effect.
- 6.2 Addenda may also be issued to modify the Bidding Documents as deemed advisable by OWNER or ENGINEER.

7 Bid Security

- 7.1 Each bid must be accompanied by Bid security made payable to OWNER in an amount of five percent of BIDDER's maximum Bid Price and in the form of a certified or bank check or a Bid Bond (on form attached, if a form is prescribed) issued by a surety.
- 7.2 The Bid security of Successful BIDDER will be retained until such BIDDER has executed the Agreement, furnished the required contract security, and met the other conditions of the Notice of Award, whereupon the Bid security will be returned. If the Successful BIDDER fails to execute and deliver the Agreement and furnish the required contract security within fifteen days after the Notice of Award, OWNER may annul the Notice of Award and the Bid security of that BIDDER will be forfeited. The Bid security of other BIDDERS whom OWNER believes to have a reasonable chance of receiving the award may be retained by OWNER until the earlier of the seventh day after the Effective Date of the Agreement or the thirty-sixth day after the Bid opening, whereupon Bid security furnished by such BIDDERS will be returned. Bid security with Bids which are not competitive will be returned within seven days after the Bid opening.

8 Contract Times

The number of days within which, or the dates by which, the Work is to be substantially completed and also completed and ready for final payment as set forth in Article 3 of the Agreement and as set forth herein.

The Work will be substantially completed with the new bridge open to traffic by **November 20, 2019**, and completed and ready for final payment by **June 30, 2020**.

9 Liquidated Damages.

Provisions for liquidated damages, if any, are set forth in Article 3 of the Agreement.

10 Substitute and “Or-Equal” Items.

The Contract, if awarded, will be on the basis of materials and equipment described in the Drawings or specified in the Specifications without consideration of possible substitute or “or-equal” items. Whenever it is indicated in the Drawings or specified in the Specifications that a substitute or “or-equal” item of material or equipment may be furnished or used by Contractor if acceptable to Engineer, application for such acceptance will not be considered by ENGINEER until after the Effective Date of the Agreement.

11 Subcontractors, Suppliers, and Others

- 11.1 If the identity of certain Subcontractors, Suppliers and other person and organizations (including those who are to furnished the principal items of material and equipment) are requested to be submitted to OWNER in advance of a specified date prior to the Effective Date of the Agreement, apparent Successful BIDDER, and any other BIDDER so requested, shall within five days after Bid opening submit to OWNER a list of all such Subcontractors, Suppliers, and other persons and organizations proposed for those portions of the Work for which such identification is required. Such list shall be accompanied by an experience statement with pertinent information regarding similar projects and other evidence of qualification for each such Subcontractor Supplier, person, or organization if requested by OWNER. An OWNER or ENGINEER who after due investigation has reasonable objection to any proposed Subcontractor, Supplier, other person, or organization, may before the Notice of Award is given request apparent Successful BIDDER to submit an acceptable substitute without an increase in Bid Price.

If apparent Successful BIDDER declines to make any such substitution, OWNER may award the contract to the next lower BIDDER that proposes to use acceptable Subcontractors, Suppliers, and other persons and organizations. The declining to make requested substitutions will not constitute grounds for sacrificing the Bid security of any BIDDER. Any subcontractors, Supplier, other person or organization listed and to whom OWNER or ENGINEER does not make written objection prior to the giving of the Notice of Award will be deemed acceptable to OWNER and ENGINEER subject to revocation of such acceptance after the Effective Date of the Agreement.

- 11.2 In contracts where the Contract Price is on the basis of Cost-of-the-Work Plus a Fee, apparent Successful BIDDER prior to the Notice of Award, shall identify in Writing to OWNER those portions of the Work that Such BIDDER proposes to subcontract and after the Notice of Award may only subcontract other portions of the Work with OWNER’s written consent.
- 11.3 No CONTRACTOR shall be required to employ any Subcontractor, Supplier, other person or organization against who CONTRACTOR has reasonable objection.

12 Bid Form

- 12.1 The Bid Form is included with the Bidding Documents; additional copies may be obtained from Engineer (or the issuing Office).
- 12.2 All blanks on the Bid Form must be completed by printing in black ink or by typewriter.
- 12.3 Bids by corporations must be executed in the corporate name by the president or a vice-president (or other corporate officer accompanied by evidence of authority to sign) and the corporate seal must be affixed and attested by the secretary or an assistant secretary. The corporate address and state of incorporation must be shown below the signature.
- 12.4 Bids by partnerships must be executed in the partnership name and signed by a partner, whose title must appear under the signature and the official address of the partnership must be shown below the signature.
- 12.5 All names must be typed or printed in black ink below the signature.
- 12.6 The Bid shall contain an acknowledgement of receipt of all Addenda (the numbers of which must be filled in on the Bid Form).
- 12.7 The address and telephone number for communications regarding the Bid must be shown.
- 12.8 Evidence of authority to conduct business as an out-of-state corporation in the state where the Work is to be performed shall be provided in accordance with Paragraph 3 above. State contractor license number, if any, must also be shown.

13 Disqualification

- 13.1 The Owner reserves the right to refuse to issue a Bid Form to a prospective BIDDER should such BIDDER be in default for any of the following reasons:
 - (a) Failure to comply with any prequalification regulations of the Owner, if such regulations are cited, or otherwise included, in the Proposal as a requirement for bidding.
 - (b) Failure to pay, or satisfactorily settle, all bills due for labor and materials on former contracts in force (with the Owner) at the time the Owner issues the Proposal to a prospective BIDDER.
 - (c) Contractor default under previous contracts with the Owner.
 - (d) Unsatisfactory work on previous contracts with the Owner.
- 13.2 Bids received from BIDDERS who have previously failed to complete contracts within the time required, or who have previously performed similar work in an unsatisfactory manner, may be rejected. A bid may be rejected if the BIDDER cannot show that he has the necessary ability, plant and equipment to commence the work at the time prescribed and thereafter to prosecute and complete the work at the rate or within the time specified. A bid may be rejected if the BIDDER is already obligated for the performance of other work which would delay the commencement, prosecution or completion of the Work.
- 13.3 The Owner reserves the right to reject any bid if the evidence submitted by, or investigation of, such BIDDER fails to satisfy the Owner that such BIDDER is properly qualified to carry out the obligations of the Contract and to complete the work contemplated therein.
- 13.4 Bids shall be considered irregular for the following reasons:

- (a) If the bid is on a form other than that furnished by the Owner, or, if the Owner's form is altered, or, if any part of the Bid Form is detached.
- (b) If there are unauthorized additions, conditional or alternate pay items, or irregularities of any kind which make the bid incomplete, indefinite, or otherwise ambiguous.
- (c) If the bid is not accompanied by the bid security specified by the Owner.

14 Submission of Bids.

Bids shall be submitted at the time and place indicated in the Advertisement of Notice to BIDDER and shall be enclosed in an opaque sealed envelope, marked with the Project title (and, if applicable, the designated portion of the Project for which the Bid is submitted) and name and address of BIDDER and accompanied by the Bid security and other required documents. If the Bid is sent through the mail or other delivery system, the sealed envelope shall be enclosed in a separate envelope with the notation "BID ENCLOSED" on the face of it.

15 Modification and Withdrawal of Bids

- 15.1 Bids may be modified or withdrawn by an appropriate document duly executed (in the manner that a Bid must be executed) and delivered to the place where Bids are to be submitted at any time prior to the opening of Bids.
- 15.2 If, within twenty-four hours after Bids are opened, any BIDDER files a duly signed, written notice with Owner and promptly thereafter demonstrates to the reasonable satisfaction of OWNER that there was a material and substantial mistake in the preparation of its Bid, that BIDDER may withdraw its Bid and bid security will be returned. Thereafter, that BIDDER will be disqualified from further bidding on the Work to be provided under the Contract Documents.

16 Opening of Bids

Bids will be opened and (unless obviously non-responsive) read aloud publicly at the place where Bids are to be submitted. An abstract of the amounts of the base Bids and major alternates (if any) will be made available to BIDDERS after the opening of Bids.

17 Bids to Remain Subject to Acceptance

All Bids will remain subject to acceptance for forty-five (45) days after the day of the Bid opening, but Owner may, in its sole discretion, release any Bid and return the Bid security prior to that date.

18 Award of Contract.

- 18.1 OWNER reserves the right to reject any or all Bids, including without limitation, the rights to reject any or all nonconforming, non-responsive, unbalanced, or conditional Bids and to reject the Bid of any BIDDER if OWNER believes that it would not be in the best interest of the Project to make an award to that BIDDER, whether because the Bid is not responsible or the BIDDER is unqualified or of doubtful financial ability or fails to meet any other pertinent standard or criteria established by OWNER. OWNER also reserves the right to waive all informalities not involving price, time, or changes in the Work and to negotiate contract terms with the Successful BIDDER. Discrepancies between words and figures will be resolved in favor of the words.

- 18.2 In evaluating Bids, OWNER will consider the qualifications of BIDDERS, whether or not the Bids comply with the prescribed requirements, and such alternates, unit prices and other data, as may be requested in the Bid Form or prior to the Notice of Award.
- 18.3 OWNER may consider the qualifications and experience of Subcontractors, Suppliers, and other persons and organizations proposed for those portions of the Work as to which the identity of Subcontractors, Suppliers, and other persons and organizations must be submitted as provided Article 11 of in the Instruction to Bidders. OWNER also may consider the operating costs, maintenance requirements, performance data and guarantees of major item of materials and equipment proposed for incorporation in the Work when such data is required to be submitted prior to the Notice of Award.
- 18.4 Owner may conduct such investigations as OWNER deems necessary to assist in the evaluation of any Bid and to establish the responsibility, qualifications, and financial ability of BIDDERS, proposed Subcontractors, Suppliers, and other persons and organizations to perform and furnish the Work in accordance with the Contract Documents to OWNER's satisfaction within the prescribed time.
- 18.5 If the contract is to be awarded, it will be awarded to lowest BIDDER whose evaluation by OWNER indicates to OWNER that the award will be in the best interests of the Project.
- 18.6 If the contract is to be awarded, OWNER will give Successful BIDDER a Notice of Award within forty-five (45) days after the day of the Bid opening.

19 Contract Security.

A Bid Security in the amount of 5% of the maximum Bid amount is required by the Contractor as part of the Bid. When the Successful BIDDER delivers the executed Agreement to OWNER, it must be accompanied by the required performance and payment Bonds.

20 Signing of Agreement

When OWNER gives a Notice of Award to the Successful BIDDER, it will be accompanied by the required number of unsigned counterparts of the Agreement with all other written Contract Documents attached. Within fifteen days thereafter CONTRACTOR shall sign and deliver the required number of counterparts of the Agreement and attached documents to OWNER with the required Bonds. Within ten days thereafter OWNER shall deliver one fully signed counterpart to CONTRACTOR. Each counterpart is to be accompanied by a complete set of the Drawings with appropriate identification.

21 Sales and Use Taxes

OWNER is exempt from New York State Sales and Use Taxes on materials and equipment to be incorporated in the Work. Said taxes should not be included in the Contract Price.

22 Retainage.

The Contract will not withhold retainage.

23 Laws and Regulations

All applicable State laws, municipal ordinances, and the rules and regulations of all authorities having jurisdiction over construction of the project shall apply to the contract throughout, they will be deemed to be included in the contract the same as though therein written out in full.

24 Coordination With Others

Insofar as possible the contractor, in carrying out his work, must employ such methods or means as will not cause any interruption of or interference with the work of any other Contractor, or operations of the Town of Newcomb unless otherwise indicated in the Special Notes or detailed Specifications.

25 Non-Collusive Bidding Certificate

All Contractors bidding under the provisions of the specifications are subject to provisions of Section 103 of the General Municipal Law of the state of New York. A signed non-collusive certification is required to be submitted with each bid in the form specified with the bid documents.

26 Basis of Award

The contract will, at the discretion of the County, be awarded on the basis of competitive bids to the lowest responsible eligible bidder based on the Base Bid.

27 Notice of Special Conditions

The contractor's attention is particularly called to those parts of the contract documents and specifications which deal with the following:

- A. Insurance requirements – Chapter 1-Item 30
- B. NYS Department of Transportation Special Conditions included in Chapter IV - Special Notes.
- C. Various Revised and Special Specifications, - Chapter V.
- D. Prevailing wage rates required by N.Y.S. Labor Law – Chapter VI.
- E. Subsurface Investigation Report – available upon request
- F. Environmental Regulation Standard Clauses and Permits, Section Chapter IV and Appendix B.
- G. Required Contract Provisions, Federal Aid Construction Contracts, Chapter VII.

28 Control of Work

28.1 Authority Of Engineer

The Essex County Department of Public Works Superintendent will be represented by an Engineer provided by the County, who will observe the work done under the Contract during construction. The Engineer shall inspect work performed, review materials to be used, and to stop and reject work and materials found to be not in accordance with the plans and specifications. The Engineer's authority shall cover all phases of the work. In the event that questions should arise concerning the interpretation or changes of plans and specifications or to the acceptability of the work, the Contractor shall submit any questions, in writing, to the Engineer. These questions shall be forwarded to the Essex County Department of Public Works along with the Engineer's recommendations.

The Engineer may place on the job other personnel who shall observe the work as direct representatives. Their authority shall consist of observing the work under the Contract, rejecting any defective material used and temporarily suspending any work improperly performed. They will not have any authority to make changes or alterations in the plans and specifications, nor be permitted to act as foremen for the Contractor.

Any work done or materials used without suitable observation by the Engineer or an authorized representative may be ordered removed and replaced at the Contractor's expense.

29 Control of Materials

All certificates of acceptability of materials required by the specifications shall be supplied by the Contractor at no expense to the sponsor. The Engineer shall have the right to approve of the laboratories or fabricators, which will issue the certificates.

The cost of the inspection by the Engineer of any unapproved plants shall be borne by the Contractor. This shall include, but not be limited to, plants employed to provide mobile concrete, precast concrete units and steel reinforcement.

The inspections and certifications for any steel or precast concrete items are to be in compliance with all the requirements of the contract plans, specifications and the Steel / Precast Concrete Construction Manuals. Particular items of importance to be checked for each unit fabricated are:

- all dimensions;
- all testing of materials

The NYSDOT Regional Materials Engineer shall be responsible for all Asphalt and Concrete plant inspection. The NYSDOT Geotechnical Engineer shall provide approval for all stockpiles and sources for granular material. In the event NYSDOT employees are unavailable, the Sponsor will provide testing in all plants. The Contractor shall provide all on-site testing as required by specifications, the Sponsor shall provide all other on-site testing as required

30 Insurance Requirements

The Contractor shall procure, at its own sole cost and expense, and shall maintain in force at all times during the term of this contract including any extensions or renewals until Contract Final Acceptance, the policies of insurance covering all operations under the contract whether performed by it or its subcontractors as herein below set forth, written by companies authorized by the New York State Insurance Department to issue insurance in the State of New York and that have an A.M. Best Company rating of (A -) or better or approved by the Department. The Department may, at its sole discretion, permit the placement of policies with a non-authorized carrier or carriers upon request by the Contractor accompanied by the documentation required by 11 NYCRR §27.0 *et seq.*; provided that nothing herein shall be construed to require the Department to accept insurance placed with a non-authorized carrier under any circumstances. The Contractor shall deliver to the Department evidence of such policies as the Department deems necessary to verify that the required insurance is in effect.

A. Conditions Applicable to Insurance. All policies of insurance required by this agreement must meet the following requirements:

1. Coverage Types and Policy Limits. The types of coverage and policy limits required from the Contractor are specified in Paragraph B *Insurance Requirements* below. General liability insurance shall apply separately on a per-job or per-project basis.

2. Policy Forms. Except as may be otherwise specifically provided herein or agreed in writing by the Department, policies must be written on an **occurrence** basis. In the event that occurrence-based coverage is not commercially available, claims-made policy forms will be considered provided that, at minimum, it includes provisions that allow for (a) reporting circumstances or incidents that may give rise to future claims and (b) an extended reporting period of not less than three (3) years with respect to events that occurred but were not reported during the term of the policy. ***Insurance policies that remove or restrict blanket contractual liability located in the “insured contract” definition (as stated in Section V, Number 9, Item f in the ISO CGL policy) or that remove or modify the “insured contract” exception to the employers liability exclusion so as to limit coverage for claims that arise out of contract work, or that do not cover the additional insured for claims involving injury to employees of the named insured or subcontractors, are not acceptable.*** Policy forms must be provided to the Department upon request.

3. Certificates of Insurance/Notices. Contractor shall provide a Certificate or Certificates of Insurance, in a form satisfactory to the County, before commencing any work under this contract. Certificates or transmittal correspondence shall reference the project identification number (PIN) and local project number listed in this proposal. Certificates shall be provided to the Owner as required in the Section III (Agreement) of this contract manual.

Name and address of Certificate Holder:

**Essex County
PO BOX 217
Elizabethtown, NY 12932**

Unless otherwise agreed, policies shall be written so as to require that the policy will not be (i) canceled, (ii) materially changed or (iii) permitted to expire or lapse for any reason except upon ten (10) days' prior written notice to the Owner by Certified Mail, Return Receipt Requested at the address stated above. In addition, if required by the Owner, the Contractor shall deliver to the Owner within ten (10) days of such request a copy of any or all policies of insurance not previously provided, certified by the insurance carrier as true and complete. Certificates of Insurance shall:

- a. Be in the form provided by the Department.. The ACORD 25 Certificate must be accompanied by an ACORD 855 “New York Construction Addendum” completed to indicate information about the liability insurance.
- b. Be signed by an authorized representative of the insurance carrier or producer.
- c. Disclose any deductible, self-insured retention, aggregate limit.
- d. Refer to this Contract by number on the face of the certificate

If at any time during the term of this contract, it shall come to the attention of the Department that required insurance is not in effect or that adequate proof of insurance has not been provided, the Department may, at its option:

- a. Direct the Contractor to suspend work and not re-enter the premises with no additional payment or extension of time due on account thereof, or
- b. May withhold further contract payments in accordance with Article 8 *No Payment Due to Contractor's Non-Compliance* of the contract agreement, or
- c. Treat such failure as a breach or default of the contract.

4. **Additional Insureds.** All insurance policies required by these specifications, except workers' compensation and professional liability shall be endorsed to provide coverage to **"The State of New York/New York State Department of Transportation, any municipality in which the work is being performed, any public benefit corporation, railroad, or public utility whose property or facilities are affected by the work, and any consultants, consultant inspecting engineering, or inspector and their agents or employees working for or on the project"** with respect to any claim arising from the Contractor's Work under this contract or as a result of the Contractor's activities. The endorsement shall be effected by endorsement of the applicable policy using ISO form CG 20 10 11 85, CG 20 37 07 04, CG 20 33 07 98 when used in combination with CG 20 37 07 04, or CG 20 33 10 01 or a form(s) that provides equivalent coverage.

ADDITIONAL INSURED PARTIES:

Essex County

Town of Newcomb

The State of New York and the Commissioner of Transportation and all employees of the Commissioner of Transportation

The People of the State of New York

Creighton Manning Engineering, LLP

NYSEG

Frontier Communications

5. **Primary Coverage.** The liability and protective liability insurance policies shall provide primary and non-contributory coverage to the Department for any claim arising from the Contractor's Work under this contract, or as a result of the Contractor's activities.

6. **Waiver of Subrogation.** As to every type and form of insurance coverage required from the Contractor, there shall be no right of subrogation against **the State of New York/New York State Department of Transportation, its agents or employees.** To the extent that any of Contractor's policies of insurance prohibit such a waiver of subrogation, Contractor shall secure the necessary permission to make this waiver.

7. **Policy Renewal/Expiration.** At least ten (10) calendar days prior to the expiration of any policy required by this contract, evidence of renewal or replacement policies of insurance with terms no less favorable to the Department than the expiring policies shall be delivered to the Department in the manner required for service of notice in Paragraph A.3. *Certificates of Insurance/Notices above.*

8. **Self-Insured Retention/Deductibles.** Contractors utilizing self-insurance programs are required to provide a description of the program for Department approval. Collateralized deductible and self-insured retention programs administered by a third party may be approved. Except as may be specifically provided in the Contract Documents of a particular project,

Contractor or third-party-administered insurance deductible shall be limited to the amount of the bid deposit or \$100,000.00, whichever is less. Security is not required if it is otherwise provided to an administrator for an approved risk management program. The Department will not accept a self-insured retention program without security being posted to assure payment of both the self-insured retention limit and the cost of adjusting claims. The Contractor shall be solely responsible for all claim expense and loss payments within any permitted deductible or self-insured retention. If the Contractor's deductible in a self-administered program exceeds the amount of the bid deposit, the Contractor shall furnish an irrevocable Letter of Credit as collateral to guarantee its obligations. Such Letter of Credit or other collateral as may be approved by Department must be issued by a guarantor or surety with an AM Best Company rating of (A -) or better. If, at any time during the term of this agreement, the Department, in its sole discretion, determines that the Contractor is not paying its deductible, it may require the Contractor to collateralize all or any part of the deductible or self-insured retention on any or all policies of insurance or, upon failure to promptly do so, the same may be withheld from payments due the Contractor.

9. Waiver of Indemnities. The Contractor waives any right of action it and/or its insurance carrier might have against the Department (including its employees, officers, commissioners, or agents) for any loss that is covered by a policy of insurance that is required by this contract. The Contractor waives any right of action it and/or its insurance carrier might have against the Department (including its employees, officers, commissioners, or agents) for any loss, whether or not such loss is insured.

10. Subcontractor's Liability Insurance. In the event that any portion of the work described in this contract is performed by an approved subcontractor, the insurance requirements of this Article shall be incorporated into the subcontract agreement. Subcontractor insurance requirements shall include the requirements for Workers' Compensation, Commercial General Liability, and, if applicable, Commercial Auto and/or Professional Liability. Excess or umbrella insurance is not required for subcontractors. Contractor shall require that Certificates of Insurance, meeting the requirements of the Department are provided to the Department documenting the insurance coverage for each and every subcontractor employed by them to do work under this contract.

B. Insurance Requirements. The types of insurance and minimum policy limits shall be as follows:

1. Workers' Compensation and Disability Insurance. As required by State Finance Law §142, the Contractor shall maintain in force workers' compensation insurance upon forms required by or acceptable to the Workers Compensation Board for all of Contractor's employees. Contractor shall also maintain disability insurance as required by the Disability Benefits Law of the State of New York.

2. Commercial General Liability Insurance. The Contractor shall maintain an occurrence form commercial general liability policy or policies insuring against liability arising from premises (including loss of use thereof), personal injury or death, advertising injury, liability insured under an insured contract (including the tort liability of another assumed in a business contract) occurring on or in any way related to the premises or occasioned by reason of the operations of Contractor. Such coverage shall be written on an ISO occurrence form (ISO Form CG 00 01 12 07 or a policy form providing equivalent coverage) in an amount of not less than \$1,000,000.00 per occurrence and not less than \$2,000,000.00 aggregate. Unless otherwise provided, the policy or policies of insurance providing the liability coverage shall include:

- a. Coverage for contractual liability assumed by the Contractor insured under an insured contract (including the tort liability of another assumed in a business contract).
- b. All insurance policies required by these specifications except workers' compensation and professional liability shall be endorsed to provide coverage to **“the State of New York/New York State Department of Transportation, any municipality in which the work is being performed, any public benefit corporation, railroad, or public utility whose property or facilities are affected by the work, and any consultants, consultant inspecting engineering, or inspector and their agents or employees working for or on the project”** using ISO form CG 20 10 11 85, CG 20 37 07 04, CG 20 33 07 98 when used in combination with CG 20 37 07 04, or CG 20 33 10 01 or a policy form or forms providing equivalent coverage.
- c. Products-Completed Operations Coverage, as provided in the General Liability Policy, or in certain instances through ISO form CG 26 11 09 99 or suitable equivalent.
- d. Where contract work will be performed by unregistered off-road equipment, Contractor shall provide documentation of a blanket Pollution Liability policy, or an endorsement to cover short-term pollution events, ISO form CG 04 33 10 01 or equivalent.
- e. Coverage for claims for bodily injury asserted by an employee of an additional insured and any Employer Liability Exclusion which may otherwise operate to exclude such coverage shall be voided in this respect.
- f. Explosion, Collapse and Underground Hazards coverage (“XCU”) (*for contracts that call for the performance of excavating, underground work, and/or the use of blasting equipment*).

3. Commercial Automobile Insurance including liability and required coverage for New York (applicable to any project where automobiles or other vehicles will be employed to complete the work). In the event that automobiles are used in connection with Contractor's business or operations with the Department, the Contractor shall maintain a commercial or other automobile policy or policies insuring against liability for bodily injury, death, or damage to property and other mandatory coverages, relating to the use, operation, loading or unloading of any of Contractor's automobiles (including owned, hired and non-owned vehicles) on and around the project. This should be ISO form CA 00 01 10 01, CA 00 01 01 87 or a policy form providing equivalent coverage along with mandatory New York endorsements. Coverage shall be in an amount of not less than \$1,000,000.00 each accident.

4. Umbrella or Excess Liability Insurance. The Contractor shall maintain an occurrence form umbrella liability policy or policies insuring against liability arising from premises (including loss of use thereof), operations, independent Contractors, products-completed operations, personal injury and advertising injury, and liability insured under an insured contract (including the tort liability of another assumed in a business contract) occurring on or in any way related to the premises or occasioned by reason of the operations of Contractor or arising from automobile liability as described above. Such coverage shall be written on an ISO occurrence form CU 00 01 12 07 or a policy form providing equivalent coverage. In the event that umbrella coverage is unavailable, equivalent excess coverage may be substituted. The minimum required limits for the umbrella/excess coverage shall be sufficient to provide a total of not less than \$5,000,000.00 per occurrence/ aggregate.

5. Special Protective and Highway Liability Policy. The Contractor shall maintain, separate and apart from its umbrella policy, a policy issued to and covering the liability of the People of the State of New York, The State of New York, the Commissioner of Transportation, all employees of the Department of Transportation both officially and personally, any municipality in which the work is being performed, any public benefit corporation, railroad, or public utility whose property or facilities are affected by the work, or any consultant inspecting engineer or inspector working for or on the project, and their agents or employees, against damages that the insureds may be held legally liable to pay for property damage, personal injuries, or death that is caused by any occurrence that takes place within any location where work is to be or is being performed by Contractor, including at the location of any of the work. This should be ISO form CG 00 14 12 or a policy form providing equivalent coverage along with mandatory New York endorsements. Coverage shall be in an amount of not less than \$1,000,000.00 per occurrence and at least \$2,000,000.00 for each aggregate limit.

6. Contractor's Risks. The Contractor shall be responsible for obtaining any insurance it deems necessary to cover its own risks, including without limitation: (a) business interruption, such as gross earnings, extra expense, or similar coverage, (b) personal property, and/or (c) automobile physical damage and/or theft. In no event shall the Department be liable for any damage to, or loss of, personal property, or damage to, or loss of, an automobile that is covered by a policy of insurance that is required by this agreement, even if such loss is caused by the negligence of the Department.

7. Professional Liability/ Errors and Omissions. *(applicable to professional services requiring the signature, stamp or certification of a licensed professional, including, without limitation, erection plans, demolition plans, containment plans, coffer dams, and temporary sheeting.)* The Contractor shall maintain at its own expense or shall require to be maintained, such insurance as is customary to compensate Department for any claims or losses that occur because of Contractor's errors, omissions malpractice or breach of professional obligations. Such policy or policies may be written on a claims-made form so long as coverage is maintained to be in effect to cover claims arising from the performance of services under this contract. Said coverage may be subject to a deductible or self-insured retention level of no more than \$250,000.00 subject to approval by Department, such approval not to be unreasonably withheld, except that it is also agreed that Department may withhold payment for services rendered under this contract in the event, and to the extent of any deductible in the event that a claim is asserted. Such coverage shall be written on a claims-made basis (or a policy form providing equivalent coverage) in an amount of no less than \$1,000,000.00 per claim and not less than \$1,000,000.00 in the aggregate.

8. Railroad Protective Liability Insurance. *(Applicable to any Work Affecting Railroads as described in §105-09.)* The Contractor shall maintain at its own expense railroad protective liability policy of insurance in the name of the affected railroad and with limits of coverage as specified in the Special Notes on Railroad Insurance, or if no limits of coverage are specified, the limits shall be not less than \$5,000,000.00 combined Bodily Injury Liability and/or Property Damage for each occurrence with a \$10,000,000.00 Aggregate Limit applying separately to each annual period. Said policy shall be subject to the approval of the railroad and comply with 23 CFR 646 Subpart A.

9. Marine Protection & Indemnity. *(applicable to any Work performed on a navigable waterway using barges or other watercraft).* Anytime the activity involves work on navigable water or the work is connected to water related activities, Marine Protection & Indemnity and Hull and Machinery coverage is required. Hull and Machinery coverage shall be provided for the total value of the watercraft or equipment. The Contractor shall obtain Protective and Indemnity Liability insurance for all marine operations under the Agreement, with a minimum (\$1,000,000) limit. The policy shall be endorsed to add the Department as an Additional Insured.

10. Pollution Liability Insurance. *(applicable where the Contractor will employ mobile equipment or tanks or facilities for fueling vehicles or equipment on-site).* The Contractor shall procure and maintain, either through an endorsement to a commercial general liability policy or through a separate policy, insurance protecting Contractor and the Department from the liability and financial loss relating to Contractor's contamination of soil and the accidental release of petroleum products, chemicals and/or toxic gases from broken pipelines, utilities and stationary and mobile fuel tanks that can result from Contractor's operations. Such coverage shall be written on policy form providing coverage for contamination both on and off the leased premises and shall provide coverage in an amount of not less than \$1,000,000. per occurrence and not less than \$1,000,000, aggregate.

11. Builders' Risks Policy. *(applicable to projects that call for the construction of any "Structure" or building, including, but not limited to pump stations and in connection with such projects, as part of a project valued at \$10,000,000 or more and then only to the extent of the value associated with such construction).* The Contractor shall procure and maintain a Builder's Risk policy in a form such as ISO form CP 00 20 10 90 or a policy form providing equivalent coverage, covering the perils insured under and including the special causes of loss form, including collapse. Subject to the allowances stated in Paragraph A. 8. *Self-Insured Retention/Deductibles*, above, the deductible not to exceed the amount of the bid deposit or \$100,000., whichever is less, covering the total value of work performed and equipment, supplies and materials at the location of the Work as well as at any off-site storage locations. Policy shall cover the structures and buildings, supplies and materials at the location of the Work as well as at any off-site storage locations. Sub-limits for loss caused by Flood and Earthquake are acceptable. The policy shall cover the cost of removing debris, including demolition as may be legally necessary by the operation of any law, ordinance or regulation, and for loss or damage to any owned, borrowed, leased or rented capital equipment, tools, including tools of their agents and employees, staging towers and forms, and property of Department held in their care, custody and/or control. Such policy shall name the Contractor as insured, and The People of the State of New York and Subcontractors as additional insureds.

31 Payment Procedures

CONTRACTOR shall submit Application for Payment in accordance with the NYSDOT Standard Specifications and will be processed by ENGINEER.

Progress Payments; OWNER shall make progress payments on account of the Contract Price on the basis of CONTRACTOR's Applications for Payment as recommended by ENGINEER, each month during construction. Such payments will be measured by the values set forth in the CONTRACTOR's Bid Schedule.

Final Payment. Upon final completion and acceptance of the Work in accordance with the NYSDOT Standard Specifications, OWNER shall pay the remainder of the Contract Price as recommended by ENGINEER as provided in the NYSDOT Standard Specifications.

32 Official Copies of this Bid

If you have obtained this Bid from a different source, you are encouraged to contact the Engineer to receive an official copy. You may not receive addenda or important information regarding this Bid if you are not registered with the Engineer as having a copy of this Bid.

BID PROPOSAL

FOR THE

CAMPSITE ROAD over the HUDSON RIVER

Bridge Replacement

BIN 3302040

PIN 1760.68; D035560

IN THE

**Town of Newcomb
Essex County, New York**

March 27, 2019

**Submitted in accordance with the Highway Law and the Standard
Specifications officially finalized and adopted on
January 01, 2019**

SUBMITTED BY:

(This Page Intentionally Left Blank)

BID FORM

PROJECT IDENTIFICATION: Campsite Road over the Hudson River Bridge Replacement;
BIN 3302040; PIN 1760.68

CONTRACT IDENTIFICATION AND NUMBER: PIN 1760.68

THIS BID IS SUBMITTED TO: Linda Wolf, Purchasing Agent,
Essex County Department of Purchasing,
7551 Court St, Elizabethtown
New York, 12932

Name and Address of Owner: Essex County Department of Purchasing
7551 Court St, Elizabethtown, NY 12932

1. The undersigned BIDDER proposes and agrees, if this Bid is accepted, to enter into an agreement with OWNER in the form included in the Contract Documents to perform and furnish all Work as specified or indicated in the Contract Documents for the Bid Price and within the Bid Times indicated in this Bid and in accordance with the other terms and conditions of the Contract Documents.
2. BIDDER accepts all of the terms and conditions of the Advertisement or Invitation to Bid and Instructions to Bidders, including without limitation those dealing with the disposition of Bid security. This Bid will remain subject to acceptance for forty-five (45) days after the day of Bid opening. BIDDER will sign and deliver the required number of counterparts of the Agreement with the Bonds and other documents required by the Bidding Requirements within fifteen days after the date of OWNER's Notice of Award.
3. In submitting this Bid, BIDDER represents as more fully set forth in the Agreement, that:
 - (a) BIDDER has examined and carefully studied the Bidding Documents and the following Addenda receipt of all which is hereby acknowledged: (List Addenda by Addendum Number and Date)

 - (b) BIDDER has visited the site and become familiar with and is satisfied as to the general, local, and site conditions that may affect cost, progress, performance, and furnishing of the Work.
 - (c) BIDDER is familiar with and is satisfied as to all federal, state, and local Laws and Regulations that may affect cost, progress, performance, and furnishing of the Work.
 - (d) BIDDER has carefully studied all reports of explorations and tests of subsurface conditions at or contiguous to the site and all drawings of physical conditions in or relating to existing surface or subsurface structures at or contiguous to the site (except underground facilities).

- (e) BIDDER is aware of the general nature of Work to be performed by OWNER and others at the site that relates to Work for which this Bid is submitted as indicated in the Contract Documents.
 - (f) BIDDER has correlated the information known to BIDDER, information and observation obtained from visits to the site, reports and drawings identified in the Contract Documents and all additional examinations, investigations, explorations, tests, studies, and data with the Contract Documents.
 - (g) BIDDER has given ENGINEER written notice of all conflicts, errors, ambiguities or discrepancies that BIDDER has discovered in the Contract Documents and the written resolution thereof by ENGINEER is acceptable to BIDDER, and the Contract Documents are generally sufficient to indicate and convey understanding of all terms and conditions for performing and furnishing the Work for which this Bid is submitted.
 - (h) This Bid is genuine and not made in the interest of or on behalf of any undisclosed person, firm, or corporation and is not submitted in conformity with any agreement or rules of any group, association, organization, or corporation; BIDDER has not directly or indirectly induced or solicited any other BIDDER to submit a false or sham Bid; BIDDER has not solicited or induced any person, firm or corporation to refrain from bidding; and BIDDER has not sought by collusion to obtain for itself any advantage over any other BIDDER or over OWNER.
4. BIDDER will complete the Work in accordance with the prices listed in the Bid Schedule.
5. The BIDDER further understands and agrees that he is to furnish and provide for the respective item price bid, all necessary material, machinery, implements, tools, labor, services and other items of whatever nature, and to do and perform all the work necessary under the aforesaid conditions, to complete the improvement of the aforementioned project in accordance with the plans and specifications for said improvement, which plans and specifications it is agreed are a part of this proposal, and to accept in full compensation therefore the amount of the summation of the products of the approximate quantities multiplied by the unit prices bid. This summation will hereinafter be referred to as the gross sum bid.
6. The BIDDER further agrees to accept the aforesaid unit bid prices as compensation for any additions or deductions caused by variation in quantities due to more accurate measurement, and for use in the computation of the value of the work performed for monthly estimates.
7. The BIDDER further agrees that at any time during the progress of the work the OWNER adds, alters or omits portions of the work he shall so perform such work and accept compensation in accordance with the NYSDOT Standard Specifications.
8. BIDDER agrees that the Work will be substantially completed and ready for final payment in accordance with the NYSDOT Standard Specifications on or before the dates or within the number of calendar days indicated in the Agreement.
- BIDDER accepts the provisions of the Agreement as to liquidated damages in the event of failure to complete the Work within the times specified in the Agreement.
9. The following documents are attached to and made a condition of this Bid:

- (a) Certified Copy of Resolution of Board of Directors (Page II-7)
- (b) Non-Interruption of Work Agreement (Page II-9)
- (c) Bid Schedule with Unit Bid Prices (Page II-13 thru II-30)
- (d) Required Bid (Security) Bond in the form of _____
- (e) Acknowledgement of Receipt of Addenda (Page II-35)
- (f) Disclosure of Lobbying Activities
- (g) Non-Collusive Bidding Certification and Bidder Information
- (h) Disadvantaged Business Enterprise Utilization Goals
- (i) Certification for Federal Aid Contracts
- (j) A tabulation of Subcontractors, Suppliers, and other persons and organizations required to be identified in this Bid (See Section 11 of the Invitation to Bidders)
- (k) Iran Divestment Act Acknowledgement

10. Communications concerning this Bid shall be addressed to: _____

The address of BIDDER indicated below.

11. Terms used in this Bid which are defined in the NYSDOT Standard Specifications will have the meanings indicated in the NYSDOT Standard Specifications except as noted.

SUBMITTED ON _____ 2019

State Contractor License No. _____

If BIDDER is:

An Individual

By _____ (SEAL)
(Individual's Name)

doing business as _____

Business address:

Phone No.: _____

A Partnership

By _____ (SEAL)
(Individual's Name)

(General partner)

Business address: _____

Phone No.: _____

A Corporation

By _____ (SEAL)
(Corporation Name)

(State of incorporation)

By _____ (SEAL)
(Name of person authorized to sign)

(Title)

Business address: _____

Phone No.: _____

(V) Date of Qualification to do business is _____

A Joint Venture

By _____ (SEAL)
(Name)

(Address)

By _____ (SEAL)
(Name)

(Address)

Phone Number and Address for receipt of official communications:

(Each joint venture firm must sign. The manner of signing for each individual, partnership and corporation that is a party to the joint venture should be in the manner indicated above.)

**CERTIFIED COPY OF RESOLUTION OF
BOARD OF DIRECTORS OF**

(NAME OF CORPORATION)

“RESOLVED that _____,
(Person Authorized to Sign) (Title)

of _____ authorized to sign and submit the Bid of this corporation
(NAME OF CORPORATION)

for the following Project:

and to include in such bid the certification as to non-collusion, and for any inaccuracies or misstatements in such certification this corporate Bidder shall be liable under the penalties of perjury.

The foregoing is a true and correct copy of the resolution adopted by

(NAME OF CORPORATION)

at a meeting of its Board of Directors held on the _____ day of _____ 2019.

By _____

Title _____

(SEAL)

The above form must be completed if the Bidder is a Corporation.

(This Page Intentionally Left Blank)

NON-INTERRUPTION OF WORK AGREEMENT

By submission of this Bid for: Essex County Department of Public Works
Campsite Road over the Hudson River – Bridge Replacement

the BIDDER agrees that if this bid is accepted, he will not intentionally engage in any course of conduct or activity, or employ for the purposes of performing the public work, any subcontractors, employees, labor or materials which will or may result in the interruption of the performance of the public work due to labor strife or unrest by workmen employed by the BIDDER or by any of the trades working in or about the public works and/or premises where the work is being performed.

Firm: _____

By: _____
(Signature)

(Typed)

Title: _____

Date: _____

(This Page Intentionally Left Blank)

BID FOR CONSTRUCTION OF
Campsite Road over the Hudson River
Bridge Replacement
(BIN 3302040)

TO THE COUNTY OF ESSEX:

Pursuant to and in compliance with your Advertisement of Invitation to Bids and the Instructions to Bidders relating thereto, the undersigned hereby offers to furnish all plant, labor, materials, supplies, equipment and other facilities and things necessary or proper for or incidental to the construction and completion of Campsite Road over the Hudson River – Bridge Replacement, required by and in strict accordance with the applicable provisions of all Contract Documents for the following unit and lump sum prices:

(This Page Intentionally Left Blank)

Brought Forward \$ _____.

ITEMIZED BID FORM							
ITEM DESCRIPTION	QTY	UNIT	UNIT PRICE IN WORDS			UNIT PRICE (NUMERALS)	TOTAL (NUMERALS)
201.06	CLEARING AND GRUBBING	1	LS	_____ Dollars	_____ Cents	\$ _____.	\$ _____.
202.120001	REMOVING EXISTING SUPERSTRUCTURES	1	LS	_____ Dollars	_____ Cents	\$ _____.	\$ _____.
202.19	REMOVAL OF SUBSTRUCTURES	278	CY	_____ Dollars	_____ Cents	\$ _____.	\$ _____.
203.01920007	WETLAND RESTORATION	166	CY	_____ Dollars	_____ Cents	\$ _____.	\$ _____.

Brought Forward \$_____.

ITEMIZED BID FORM							
ITEM DESCRIPTION	QTY	UNIT	UNIT PRICE IN WORDS			UNIT PRICE (NUMERALS)	TOTAL (NUMERALS)
203.02	UNCLASSIFIED EXCAVATION AND DISPOSAL	678	CY	_____ Dollars	_____ Cents	\$_____.	\$_____.
203.03	EMBANKMENT IN PLACE	708	CY	_____ Dollars	_____ Cents	\$_____.	\$_____.
203.21	SELECT STRUCTURE FILL	335	CY	_____ Dollars	_____ Cents	\$_____.	\$_____.
206.01	STRUCTURE EXCAVATION	1500	CY	_____ Dollars	_____ Cents	\$_____.	\$_____.

Brought Forward \$_____.

ITEMIZED BID FORM							
ITEM DESCRIPTION	QTY	UNIT	UNIT PRICE IN WORDS			UNIT PRICE (NUMERALS)	TOTAL (NUMERALS)
206.0201	TRENCH AND CULVERT EXCAVATION	33	CY	_____ Dollars	_____ Cents	\$_____.	\$_____.
207.27	PREFABRICATED COMPOSITE INTEGRAL ABUTMENT DRAIN	130	SY	_____ Dollars	_____ Cents	\$_____.	\$_____.
209.13	SILT FENCE-TEMPORARY	930	LF	_____ Dollars	_____ Cents	\$_____.	\$_____.
209.1501	TURBIDITY CURTAIN - TEMPORARY	128	LF	_____ Dollars	_____ Cents	\$_____.	\$_____.

Brought Forward \$_____.

ITEMIZED BID FORM							
ITEM DESCRIPTION	QTY	UNIT	UNIT PRICE IN WORDS			UNIT PRICE (NUMERALS)	TOTAL (NUMERALS)
209.190301	ROLLED EROSION CONTROL PRODUCT, CLASS II TYPE C, INTERMEDIATE	627	SY	_____ Dollars	_____ Cents	\$_____.	\$_____.
304.12	SUBBASE COURSE, TYPE 2	519	CY	_____ Dollars	_____ Cents	\$_____.	\$_____.
402.000013	PLANT PRODUCTION QUALITY ADJUSTMENT TO HMA ITEMS	26	QU	<u>FIXED PRICE SPECIFICATION</u>		\$_____ 75.00	\$_____ 1,965.00
402.128303	12.5 F3 TOP COURSE HMA, 80 SERIES COMPACTION	108	TON	_____ Dollars	_____ Cents	\$_____.	\$_____.

Brought Forward \$_____.

ITEMIZED BID FORM							
ITEM DESCRIPTION	QTY	UNIT	UNIT PRICE IN WORDS			UNIT PRICE (NUMERALS)	TOTAL (NUMERALS)
402.198903	19 F9 BINDER COURSE HMA, 80 SERIES COMPACTION	186	TON	_____ Dollars	_____ Cents	\$_____.	\$_____.
402.378903	37.5 F9 BASE COURSE HMA, 80 SERIES COMPACTION	230	TON	_____ Dollars	_____ Cents	\$_____.	\$_____.
407.0102	DILUTED TACK COAT	164	GAL	_____ Dollars	_____ Cents	\$_____.	\$_____.
553.020001	COFFERDAMS (TYPE 2)	1	EACH	_____ Dollars	_____ Cents	\$_____.	\$_____.

Brought Forward \$_____.

ITEMIZED BID FORM							
ITEM DESCRIPTION	QTY	UNIT	UNIT PRICE IN WORDS			UNIT PRICE (NUMERALS)	TOTAL (NUMERALS)
553.020002	COFFERDAMS (TYPE 2)	1	EACH	_____ Dollars	_____ Cents	\$_____.	\$_____.
555.0104	FOOTING CONCRETE CLASS A (NO CONCRETE CLASS SUBSTITUTIONS PERMITTED, EXCEPT CLASS H WHERE FOOTING IS 3 FT THICK OR LESS)	17	CY	_____ Dollars	_____ Cents	\$_____.	\$_____.
555.08	FOOTING CONCRETE, CLASS HP	68	CY	_____ Dollars	_____ Cents	\$_____.	\$_____.
555.09	CONCRETE FOR STRUCTURES, CLASS HP	124	CY	_____ Dollars	_____ Cents	\$_____.	\$_____.

Brought Forward \$_____.

ITEMIZED BID FORM							
ITEM DESCRIPTION	QTY	UNIT	UNIT PRICE IN WORDS			UNIT PRICE (NUMERALS)	TOTAL (NUMERALS)
556.0201	UNCOATED BAR REINFORCEMENT FOR CONCRETE STRUCTURES	12700	LB	_____ Dollars	_____ Cents	\$_____.	\$_____.
556.0202	EPOXY-COATED BAR REINFORCEMENT FOR STRUCTURES	18960	LB	_____ Dollars	_____ Cents	\$_____.	\$_____.
556.03	STUD SHEAR CONNECTORS FOR BRIDGES	1010	EACH	_____ Dollars	_____ Cents	\$_____.	\$_____.
557.0103	SUPERSTRUCTURE SLAB WITH INTEGRAL WEARING SURFACE - BOTTOM FORMWORK REQUIRED - TYPE 3 FRICTION	322	SY	_____ Dollars	_____ Cents	\$_____.	\$_____.

Brought Forward \$_____.

ITEMIZED BID FORM							
ITEM DESCRIPTION	QTY	UNIT	UNIT PRICE IN WORDS			UNIT PRICE (NUMERALS)	TOTAL (NUMERALS)
557.2003	STRUCTURAL APPROACH SLAB WITH INTEGRAL WEARING SURFACE - TYP E 3 FRICTION	61	SY	_____ Dollars	_____ Cents	\$_____.	\$_____.
557.29	WINTER SURFACE TREATMENT - SUPERSTRUCTURE SLABS AND STRUCTURAL APPROACH SLABS	383	SY	_____ Dollars	_____ Cents	\$_____.	\$_____.
558.02	LONGITUDINAL SAWCUT GROOVING OF STRUCTURAL SLAB SURFACE	336	SY	_____ Dollars	_____ Cents	\$_____.	\$_____.
559.18960118	PROTECTIVE SEALING OF STRUCTURAL CONCRETE ON NEW BRIDGE DECKS AND BRIDGE DECK OVERLAYS	3835	SF	_____ Dollars	_____ Cents	\$_____.	\$_____.

Brought Forward \$_____.

ITEMIZED BID FORM							
ITEM DESCRIPTION	QTY	UNIT	UNIT PRICE IN WORDS			UNIT PRICE (NUMERALS)	TOTAL (NUMERALS)
564.0501	STRUCTURAL STEEL, TYPE 1	1	LS	_____ Dollars	_____ Cents	\$_____.	\$_____.
565.2032	TYPE E.B EXPANSION BEARING (56 TO 111 KIPS)	10	EACH	_____ Dollars	_____ Cents	\$_____.	\$_____.
568.51	STEEL BRIDGE RAILING (FOUR RAIL)	255	LF	_____ Dollars	_____ Cents	\$_____.	\$_____.
568.70	TRANSITION BRIDGE RAILING	128	LF	_____ Dollars	_____ Cents	\$_____.	\$_____.

Brought Forward \$_____.

ITEMIZED BID FORM							
ITEM DESCRIPTION	QTY	UNIT	UNIT PRICE IN WORDS			UNIT PRICE (NUMERALS)	TOTAL (NUMERALS)
570.01	LEAD EXPOSURE CONTROL PLAN	1	LS	_____ Dollars	_____ Cents	\$_____.	\$_____.
570.09	ENVIRONMENTAL GROUND PROTECTION	1	LS	_____ Dollars	_____ Cents	\$_____.	\$_____.
570.10	ENVIRONMENTAL WATERWAY PROTECTION	1	LS	_____ Dollars	_____ Cents	\$_____.	\$_____.
571.03	DISPOSAL OF HAZARDOUS PAINT WASTE CONTAINING LEAD	105	LB	_____ Dollars	_____ Cents	\$_____.	\$_____.

Brought Forward \$_____.

ITEMIZED BID FORM							
ITEM DESCRIPTION	QTY	UNIT	UNIT PRICE IN WORDS			UNIT PRICE (NUMERALS)	TOTAL (NUMERALS)
572.010001	STRUCTURAL STEEL PAINT SYSTEM: SHOP APPLIED	2176	SF	_____ Dollars	_____ Cents	\$_____.	\$_____.
606.10	BOX BEAM GUIDE RAILING	90	LF	_____ Dollars	_____ Cents	\$_____.	\$_____.
606.100002	BOX BEAM GUIDE RAILING (SHOP BENT OR SHOP MITERED)	155	LF	_____ Dollars	_____ Cents	\$_____.	\$_____.
606.120101	BOX BEAM END PIECE	4	EACH	_____ Dollars	_____ Cents	\$_____.	\$_____.

Brought Forward \$_____.

ITEMIZED BID FORM							
ITEM DESCRIPTION	QTY	UNIT	UNIT PRICE IN WORDS			UNIT PRICE (NUMERALS)	TOTAL (NUMERALS)
606.71	REMOVING AND DISPOSING CORRUGATED BEAM GUIDE RAILING	501	LF	_____ Dollars	_____ Cents	\$_____.	\$_____.
607.41010010	TEMPORARY PLASTIC BARRIER FENCE	800	LF	_____ Dollars	_____ Cents	\$_____.	\$_____.
608.020102	HOT MIX ASPHALT (HMA) SIDEWALKS, DRIVEWAYS AND BICYCLE PATHS ,AND VEGETATION CONTROL STRIPS	31	TON	_____ Dollars	_____ Cents	\$_____.	\$_____.
610.1401	TOPSOIL - REUSE ON-SITE MATERIALS	80	CY	_____ Dollars	_____ Cents	\$_____.	\$_____.

Brought Forward \$_____.

ITEMIZED BID FORM							
ITEM DESCRIPTION	QTY	UNIT	UNIT PRICE IN WORDS			UNIT PRICE (NUMERALS)	TOTAL (NUMERALS)
610.16010424	TURF ESTABLISHMENT - SEED MIX AS SPECIFIED ROADSIDE SEED MIX	597	CY	_____ Dollars	_____ Cents	\$_____.	\$_____.
619.01	BASIC WORK ZONE TRAFFIC CONTROL	1	LS	_____ Dollars	_____ Cents	\$_____.	\$_____.
619.04	TYPE III CONSTRUCTION BARRICADE	4	EACH	_____ Dollars	_____ Cents	\$_____.	\$_____.
619.0601	TEMPORARY STRUCTURES AND APPROACHES NO 1	1	EACH	_____ Dollars	_____ Cents	\$_____.	\$_____.

Brought Forward \$ _____.

ITEMIZED BID FORM							
ITEM DESCRIPTION	QTY	UNIT	UNIT PRICE IN WORDS			UNIT PRICE (NUMERALS)	TOTAL (NUMERALS)
619.0903	TEMPORARY PAVEMENT MARKINGS STRIPES (REMOVABLE TAPE)	1000	LF	_____ Dollars	_____ Cents	\$ _____.	\$ _____.
619.100103	INTERIM PAVEMENT MARKINGS, STRIPES (REMOVABLE TAPE)	24	LF	_____ Dollars	_____ Cents	\$ _____.	\$ _____.
619.1301	TEMPORARY TRAFFIC SIGNALS	1	ELOC	_____ Dollars	_____ Cents	\$ _____.	\$ _____.
620.05	STONE FILLING (HEAVY)	212	CY	_____ Dollars	_____ Cents	\$ _____.	\$ _____.

Brought Forward \$_____.

ITEMIZED BID FORM						
ITEM DESCRIPTION	QTY	UNIT	UNIT PRICE IN WORDS		UNIT PRICE (NUMERALS)	TOTAL (NUMERALS)
620.0801	BEDDING MATERIAL, TYPE 1	42	CY	_____ Dollars _____ Cents	\$_____.	\$_____.
625.01	SURVEY OPERATIONS	1	LS	_____ Dollars _____ Cents	\$_____.	\$_____.
627.50140008	CUTTING PAVEMENT	44	LF	_____ Dollars _____ Cents	\$_____.	\$_____.
637.11	ENGINEER'S FIELD OFFICE - TYPE 1	6	MNTH	_____ Dollars _____ Cents	\$_____.	\$_____.

Brought Forward \$_____.

ITEMIZED BID FORM							
ITEM DESCRIPTION	QTY	UNIT	UNIT PRICE IN WORDS			UNIT PRICE (NUMERALS)	TOTAL (NUMERALS)
637.34	OFFICE TECHNOLOGY AND SUPPLIES	3000	DC	_____ Dollars	_____ Cents	\$_____.	\$_____.
645.5202	GROUND-MOUNTED SIGN PANELS LESS THAN OR EQUAL TO 30 SF, WITH Z-BARS, HIGH-VISIBILITY SHEETING	1	SF	_____ Dollars	_____ Cents	\$_____.	\$_____.
645.81	TYPE A SIGN POSTS	4	EACH	_____ Dollars	_____ Cents	\$_____.	\$_____.
646.22	DELINEATOR, SNOWPLOWING MARKER, SUPPLEMENTARY SNOWPLOWING MARKER PANELS	4	EACH	_____ Dollars	_____ Cents	\$_____.	\$_____.

Brought Forward \$_____.

ITEMIZED BID FORM						
ITEM DESCRIPTION	QTY	UNIT	UNIT PRICE IN WORDS		UNIT PRICE (NUMERALS)	TOTAL (NUMERALS)
647.31	RELOCATE SIGN PANEL, SIGN PANEL ASSEMBLY SIZE I (UNDER 30 SQUARE FEET)	3	EACH	_____ Dollars _____ Cents	\$_____.	\$_____.
647.61	REM AND DISPOSE GROUND MOUNTED TYPE A SIGN SUPPORT(S), FDNS AND ANY ATTACHED SIGNS - SIZE I (UNDER 30 SQUARE FEET)	3	EACH	_____ Dollars _____ Cents	\$_____.	\$_____.
697.03	FIELD CHANGE PAYMENT	93000	DC	<u>FIXED PRICE SPECIFICATION</u>	\$ 1.00	\$ <u>93,000.00</u>
698.04	ASPHALT PRICE ADJUSTMENT	100	DC	<u>FIXED PRICE SPECIFICATION</u>	\$ 1.00	\$ <u>100.00</u>

Brought Forward \$_____.

ITEMIZED BID FORM						
ITEM DESCRIPTION	QTY	UNIT	UNIT PRICE IN WORDS	UNIT PRICE (NUMERALS)	TOTAL (NUMERALS)	
698.05	FUEL PRICE ADJUSTMENT	100	DC	<u>FIXED PRICE SPECIFICATION</u>	\$ 1.00	\$ 100.00
698.06	STEEL/IRON PRICE ADJUSTMENT	100	DC	<u>FIXED PRICE SPECIFICATION</u>	\$ 1.00	\$ 100.00
PIN 1760.68 Subtotal Sum Bid				_____ Dollars	\$_____.	\$_____.
				_____ Cents		

Brought Forward \$_____.

ITEMIZED BID FORM							
ITEM DESCRIPTION	QTY	UNIT	UNIT PRICE IN WORDS			UNIT PRICE (NUMERALS)	TOTAL (NUMERALS)
698.05	MOBILIZATION	1	LS	_____ Dollars		\$_____.	\$_____.
				_____ Cents			
PIN 1760.68 Total Sum Bid				_____ Dollars		\$_____.	\$_____.
				_____ Cents			

Accompanying this Bid, is a Bid security in the form of a bid bond for the sum of _____ (\$ _____) Dollars. In case this Bid is accepted by the Owner, and the undersigned shall fail to execute a contract with and give the required bonds to the Owner within five (5) days after the date of a written notice by the Owner to the undersigned so to do, this Bid security shall be forfeited and will be retained by the Owner as liquidated damages.

Dated _____, 2019

Signature of Bidder

Print Name of Signer of Bid: _____

Address:

** Insert bidder’s name; if a corporation, give the state of incorporation using the phrase “a corporation organized under the law of”; if a partnership, give the name of the partners, using also the phrase “co-partners trading and doing business under the firm name and style of”; if an individual using a trade name, give individual name, using also the phrase “an individual doing business under the firm name and style of”.

(This Page Intentionally Left Blank)

BID (SECURITY) BOND

Any singular reference to Bidder, Surety, Owner, or other party shall be considered plural where applicable.

BIDDER (Name and Address):

SURETY (Name and Address of Principal Place of Business):

OWNER (Name and Address):

BID

Bid Due Date:

Project (Brief Description Including Location):

BOND

Bond Number:

Date (Not later than Bid due date):

Penal sum _____ (Words) _____ (Figures)

Surety and Bidder, intending to be legally bound hereby, subject to the terms printed on the reverse side hereof, do each cause this Bid Bond to be duly executed on its behalf by its authorized officer, agent, or representative.

BIDDER

SURETY

Bidder's Name and Corporate Seal (Seal)

Surety's Name and Corporate Seal (Seal)

By: _____
Signature and Title

By: _____
Signature and Title
(Attach Power of Attorney)

Attest: _____
Signature and Title

Attest: _____
Signature and Title

Note: Above addresses are to be used for giving required notice.

1. Bidder and Surety, jointly and severally, bind themselves, their heirs, executors, administrators, successors and assigns to pay to Owner upon default of Bidder the penal sum set forth on the face of this Bond. Payment of the penal sum is the extent of Surety's liability.
2. Default of Bidder shall occur upon the failure of Bidder to deliver within the time required by the Bidding Documents (or any extension thereof agreed to in writing by Owner) the executed Agreement required by the Bidding Documents and any performance and payment bonds required by the Bidding Documents.
3. This obligation shall be null and void if:
 - 3.1. Owner accepts Bidder's Bid and Bidder delivers within the time required by the Bidding Documents (or any extension thereof agreed to in writing by Owner) the executed Agreement required by the Bidding Documents and any performance and payment bonds required by the Bidding Documents, or
 - 3.2. All Bids are rejected by Owner, or
 - 3.3. Owner fails to issue a Notice of Award to Bidder within the time specified in the Bidding Documents (or any extension thereof agreed to in writing by Bidder and, if applicable, consented to by Surety when required by Paragraph 5 hereof).
4. Payment under this Bond will be due and payable upon default by Bidder and within 30 calendar days after receipt by Bidder and Surety of written notice of default from Owner, which notice will be given with reasonable promptness, identifying this Bond and the Project and including a statement of the amount due.
5. Surety waives notice of any and all defenses based on or arising out of any time extension to issue Notice of Award agreed to in writing by Owner and Bidder, provided that the total time for issuing Notice of Award including extensions shall not in the aggregate exceed 120 days from Bid due date without Surety's written consent.
6. No suit or action shall be commenced under this Bond prior to 30 calendar days after the notice of default required in Paragraph 4 above is received by Bidder and Surety and in no case later than one year after Bid due date.
7. Any suit or action under this Bond shall be commenced only in a court of competent jurisdiction located in the state in which the Project is located.
8. Notices required hereunder shall be in writing and sent to Bidder and Surety at their respective addresses shown on the face of this Bond. Such notices may be sent by personal delivery, commercial courier, or by United States Registered or Certified Mail, return receipt requested, postage pre-paid, and shall be deemed to be effective upon receipt by the party concerned.
9. Surety shall cause to be attached to this Bond a current and effective Power of Attorney evidencing the authority of the officer, agent, or representative who executed this Bond on behalf of Surety to execute, seal, and deliver such Bond and bind the Surety thereby.
10. This Bond is intended to conform to all applicable statutory requirements. Any applicable requirement of any applicable statute that has been omitted from this Bond shall be deemed to be included herein as if set forth at length. If any provision of this Bond conflicts with any applicable statute, then the provision of said statute shall govern and the remainder of this Bond that is not in conflict therewith shall continue in full force and effect.
11. The term "Bid" as used herein includes a Bid, offer, or proposal as applicable.

ACKNOWLEDGMENT OF RECEIPT OF ADDENDA

The undersigned acknowledges receipt of the following addenda to the subject project (if none, state "NONE"):

Addendum No. _____ dated _____

Addendum No. _____ dated _____

Addendum No. _____ dated _____

Receipt is hereby acknowledged for all addenda listed above.

COMPANY NAME _____

AUTHORIZED SIGNATURE _____

PRINTED NAME _____

TITLE _____

DATE _____

(This Page Intentionally Left Blank)

INSTRUCTIONS FOR COMPLETION OF SF-LLL, DISCLOSURE OF LOBBYING ACTIVITIES

This disclosure form shall be completed by the reporting entity, whether subawardee or prime Federal recipient, at the initiation or receipt of a covered Federal action, or a material change to a previous filing, pursuant to title 31 U.S.C. section 1352. The filing of a form is required for each payment or agreement to make payment to any lobbying entity for influencing or attempting to influence an officer or employee of any agency, Member of Congress, an officer or employee of Congress, or an employee of a Member of Congress in connection with a covered Federal action. Complete all items that apply for both the initial filing and material change report. Refer to the implementing guidance published by the Office of Management and Budget for additional information.

1. Identify the type of covered Federal action for which lobbying activity is and/or has been secured to influence the outcome of a covered Federal action.
2. Identify the status of the covered Federal action.
3. Identify the appropriate classification of this report. If this is a follow-up report caused by a material change to the information previously reported, enter the year and quarter in which the change occurred. Enter the date of the last previously submitted report by this reporting entity for this covered Federal action.
4. Enter the full name, address, city, state and zip code of the reporting entity. Include Congressional District, if known. Check the appropriate classification of the reporting entity that designates if it is, or expects to be, a prime or subawardee. Identify the tier of the subawardee, e.g., the first subawardee of the prime is the 1st tier. Subawards include but are not limited to subcontracts, subgrants, and contract awards under grants.
5. If the organization filing the report in item 4 checks “Subawardee”, then enter the full name, address, city, state and zip code of the prime Federal recipient. Include Congressional District, if known.
6. Enter the name of the Federal agency making the award or loan commitment. Include at least one organizational level below agency name, if known. For example, Department of Transportation, United States Coast Guard.
7. Enter the Federal program name or description for the covered Federal action (item 1). If known, enter the full Catalog of Federal Domestic Assistance (CFDA) number for grants, cooperative agreements, loans, and loan commitments.
8. Enter the most appropriate Federal identifying number available for the Federal action identified in item 1 (e.g., Request for Proposal (RFP) number; Invitation for Bid (IFB) number; grant announcement number; the contract, grant, or loan award number; the application/proposal control number assigned by the Federal agency). Include prefixes, e.g., “RFP-DE-90-001”.
9. For a covered Federal action where there has been an award or loan commitment by the Federal agency, enter the Federal amount of the award/loan commitment for the prime entity identified in item 4 or 5.
10. (a) Enter the full name, address, city, state and zip code for the lobbying registrant under the Lobbying Disclosure Act of 1995 engaged by the reporting entity identified in item 4 to influence the Federal covered action.

(b) Enter the full names of the individual(s) performing services, and include full address if different from 10(a). Enter Last Name, First Name, and Middle Initial (MI).

11. The certifying official shall sign and date the form; print his/her name, title, and telephone number.

According to the Paperwork Reduction Act, as amended, no persons are required to respond to a collection of information unless it displays a valid OMB Control Number. The valid OMB Control Number for this information collection is OMB No. 0348-0046. Public reporting burden for this collection of information is estimated to average 10 minutes per response, including time for reviewing instructions, searching existing data sources, gathering and maintaining the data needed, and completing and reviewing the collection of information. Send comments regarding the burden estimate or any other aspect of this collection of information, including suggestions for reducing this burden, to the Office of Management and Budget, Paperwork Reduction Project (0348-0046), Washington D.C. 20503.

DISCLOSURE OF LOBBYING ACTIVITIES

Complete this form to disclose lobbying activities pursuant to 31 U.S.C. 1352 (See reverse for public burden disclosure.)

1. Type of Federal Action:		2. Status of Federal Action:		3. Report Type:	
a. contract		a. bid/offer/application		a. initial filing	
b. grant		b. initial award		b. material change	
c. cooperative agreement		c. post-award		For Material Change Only:	
d. loan				year _____ quarter _____	
e. loan guarantee				date of last report _____	
f. loan insurance					
4. Name and Address of Reporting Entity: <input type="checkbox"/> Prime <input type="checkbox"/> Subawardee Tier _____, if known:			5. If Reporting Entity in No. 4 is a Subawardee, Enter Name and Address of Prime:		
Congressional District, if known:			Congressional District, if known:		
6. Federal Department/Agency:			7. Federal Program Name/Description:		
			CFDA Number, if applicable:		
8. Federal Action Number, if known:			9. Award Amount, if known:		
			\$ _____		
10. a. Name and Address of Lobbying Registrant (if individual, last name, first name, MI):			b. Individuals Performing Services (including address if different from No. 10a) (last name, first name, MI):		
<p>11. Information requested through this form is authorized by title 31 U.S.C. section 1352. This disclosure of lobbying activities is a material representation of fact upon which reliance was placed by the tier above when this transaction was made or entered into. This disclosure is required pursuant to 31 U.S.C. 1352. This information will be available for public inspection. Any person who fails to file the required disclosure shall be subject to a civil penalty of not less than \$10,000 and not more than \$100,000 for each such failure.</p>			Signature:		
			Print Name:		
			Title:		
			Telephone No.:		Date:
Federal Use Only:				Authorized for Local Reproduction Standard Form LLL (Rev. 7-97)	

REQUIREMENTS REGARDING LOBBYING ACTIVITIES ON FEDERAL AID CONTRACTS

DISCLOSURE OF LOBBYING ACTIVITIES
Continuation Sheet

Approved by OMB
0348-0046

Reporting Entity: _____ Page _____ Of _____

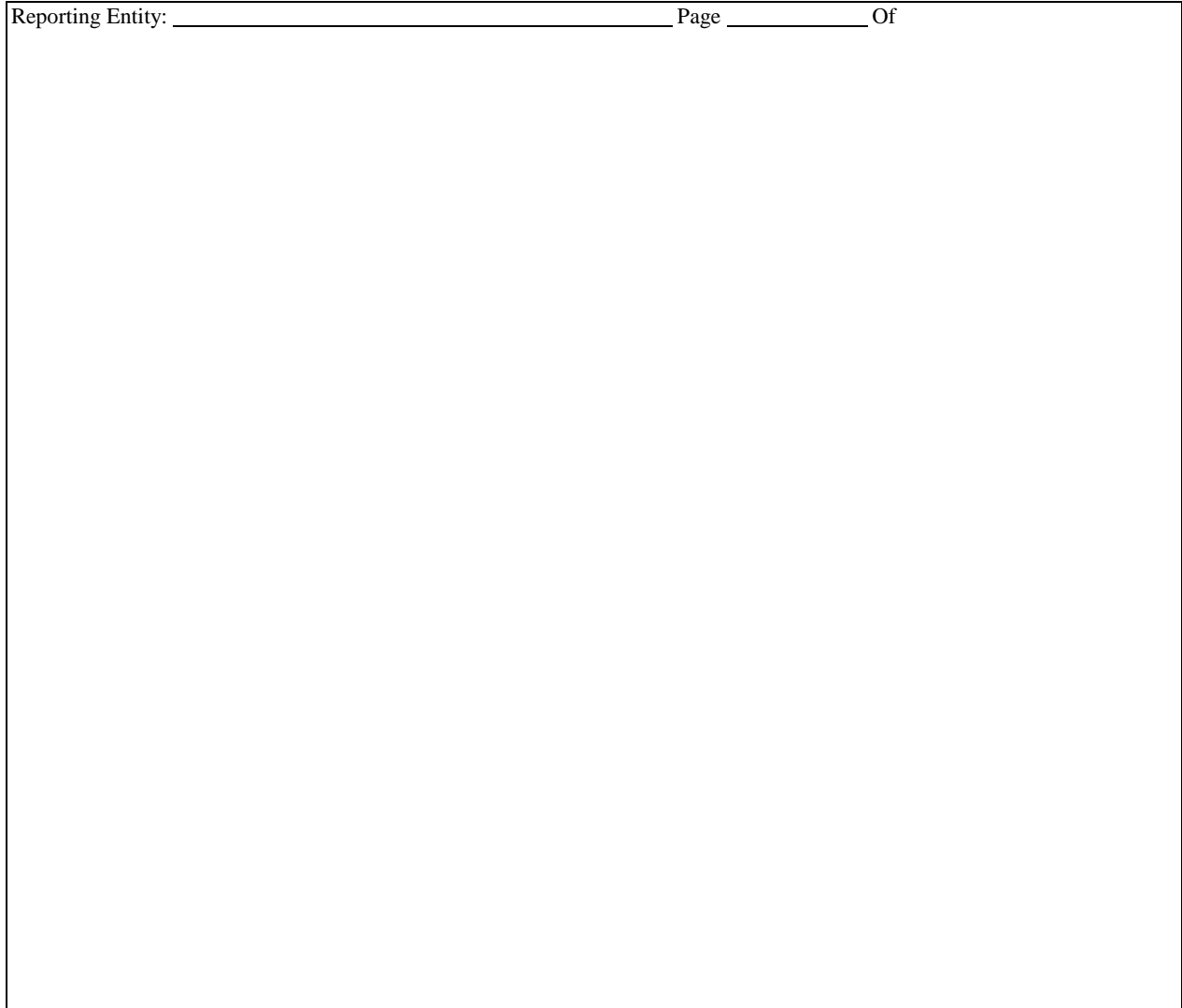

Authorized for Local Reproduction - Standard Form LLL

NON-COLLUSIVE BIDDING CERTIFICATIONS

REQUIRED BY SECTION 139-D, STATE FINANCE LAW and SECTION 103-D OF GENERAL MUNICIPAL LAW

“Section 139-d, SFL and Section 103-d, GML, “Statement of non-collusion in bids to the state.”

1. Every bid hereafter made to the state or any public department, agency, or official thereof, where competitive bidding is required by statute, rule, or regulation, for work or services performed or to be performed or goods sold or to be sold, shall contain the following statement subscribed by the bidder and affirmed by such bidder as true under the penalties of perjury:

Non-collusive bidding certification.

(a) By submission of this bid, each bidder and each person signing on behalf of any bidder certifies, and in the case of a joint bid, each party thereto certifies as to its own organization, under penalty of perjury, that to the best of his knowledge and belief:

(1) The prices in this bid have been arrived at independently without collusion, consultation, communication, or agreement, for the purpose of restricting competition, as to any matter relating to such prices with any other bidder or with any competitor;

(2) Unless otherwise required by law, the prices which have been quoted in this bid have not been knowingly disclosed by the bidder and will not knowingly be disclosed by the bidder prior to opening, directly or indirectly, to any other bidder or to any competitor; and

(3) No attempt has been made or will be made by the bidder to induce any other person, partnership, or corporation to submit or not to submit a bid for the purpose of restricting competition.

(b) A bid shall not be considered for award nor shall any award be made where (a)(1)(2) and (3) above have not been complied with; provided however, that if in any case the bidder cannot make the foregoing certification, the bidder shall so state and shall furnish with the bid a signed statement which sets forth in detail the reasons therefore. Where (a)(1)(2) and (3) above have not been complied with, the bid shall not be considered for award nor shall any award be made unless the head of the purchasing unit of the state, public department, or agency to which the bid is made, or his designee, determines that such disclosure was not made for the purpose of restricting competition.

The fact that the bidder (a) has published price lists, rates, or tariffs covering items being procured, (b) has informed prospective customers of proposed or pending publication of new or revised price lists for such items or (c) has sold the same items to other customers at the same prices being bid, does not constitute, without more, a disclosure within the meaning of subparagraph one (a).

2. Any bid hereafter made to the state or any public department, agency, or official thereof by a corporate bidder for work or services performed or to be performed or goods sold or to be sold, where competitive bidding is required by statute, rule, or regulation, and where such bid contains the certification referred to in subdivision one of this section, shall be deemed to have been authorized by the board of directors of the bidder and such authorization shall be deemed to have included the signing and submission of the bid and the inclusion therein of the certificate as to non collusion as the act and deed of the corporation."

(A) 2

"By submission of this bid, the bidder does hereby tender to the Owner this sworn statement pursuant to Section 1128 of Title 23, U. S. Code-Highways and does hereby certify, in conformance with said Section 112 of Title 23, U. S. Code-Highways that the said Contractor has not, either directly or indirectly, entered into any agreement, participated in any collusion, or otherwise taken any action in restraint of free competitive bidding in connection with the above contract."

REQUIRED BY TITLE 49, CFR, VOLUME 1, SUBTITLE A, PART 29

"The signatory to the proposal, being duly sworn, certifies that, EXCEPT AS NOTED BELOW, his/her company and any person associated therewith in the capacity of owner, partner, director, officer, or major stockholder (of five percent or more ownership):

1. Is not currently under suspension, debarment, voluntary exclusion, or determination of ineligibility by any Federal agency;
2. Has not been suspended, debarred, voluntarily excluded, or determined ineligible by any Federal agency within the past three years;
3. Does not have a proposed debarment pending; and
4. Has not been indicted, convicted, or had a civil judgment rendered against it by a court of competent jurisdiction in any matter involving fraud or official misconduct within the past three years.

EXCEPTIONS: The Contractor should list any relevant information, attaching additional sheets to the proposal if necessary. (Exceptions will not necessarily result in disapproval, but will be considered in determining responsibility. For any exception noted, the Contractor should indicate to whom it applies, the initiating agency, and the dates of actions. Providing false information may result in criminal prosecution or administrative sanctions).

BY EXECUTING THIS DOCUMENT, THE CONTRACTOR AGREES TO:

1. Perform all work listed in accordance with the Contract Documents at the unit prices bid; subject to the provisions of Section 104 -04, Standard Specifications published by the New York State Department of Transportation if applicable;
2. All the terms and conditions of the non-collusive bidding certifications required by Section 139-d of the State Finance Law, and Section 112, Title 23, U.S. Code;
3. Certification of Specialty Items category selected, if contained in this proposal;
4. Certification of any other clauses required by this proposal and contained herein;
5. Certification, under penalty of perjury, as to the current history regarding suspensions, debarments, voluntary exclusions, determinations of ineligibility, indictments, convictions, or civil judgments required by 49 CFR Part 29.

(Legal Name of Person, Corporation, or Firm Which
is Submitting Bid or Proposal)

Date:

BY: _____
(Signature of Person Representing Above)

AS: _____
(Official Title of Signator in Above Firm)

(Acknowledgment by Individual Contractor, If a Corporation)

STATE OF NEW YORK

COUNTY OF _____ SS:

On this _____ day of _____, 2019, before me personally came _____, to me known and known to me to be the person who executed the above instrument, who being duly sworn by me, did depose and say that he/she resides at _____, and that he/she is the _____ of _____, the corporation described in and which executed the above instrument, and that he/she signed his/her name thereto on behalf of said Corporation by order of the Board of Directors of said Corporation.

Notary Public

(Acknowledgment by Co-Partnership Contractor)

STATE OF NEW YORK

COUNTY OF _____ SS:

On this _____ day of _____, 2019, before me personally came _____, to me known and known to me to be the person described in and who executed the above instrument, who, being duly sworn by me, did for himself/herself depose and say that he/she is a member of the partnership of _____, consisting of himself/herself and _____, and that he/she executed the foregoing instrument in the firm name of _____ and that he/she had authority to sign same, and did duly acknowledge to me that he/she executed same as the act and deed of said firm for the uses and purposes mentioned herein.

Notary Public

(Acknowledgment by Individual Contractor)

STATE OF NEW YORK

COUNTY OF _____ SS:

On this _____ day of _____, 2019, before me personally came
_____, to me known and known to me to
be the person described in and who executed the foregoing instrument, and that he/she acknowledged that
he/she executed the same.

Notary Public

NON-COLLUSIVE BIDDING CERTIFICATION BIDDER INFORMATION

Bidder to provide information listed below:

Bidder Address: _____
Street or P. O. Box No. _____
City _____
State/Zip Code _____

Federal Identification No.: _____

Name of Contact Person: _____

Phone # of Contact Person: _____

If Bidder is a Corporation:

President's Name & Address:

Secretary's Name & Address:

Treasurer's Name & Address:

If Bidder is a Partnership:

Partner's Name & Address:

Partner's Name & Address:

If Bidder is a Sole Proprietorship:

Owner's Name & Address:

**REPORTING VIOLATIONS OF NON-COLLUSIVE BIDDING PROCEDURES,
MISCONDUCT, OR OTHER PROHIBITED CONTRACT ACTIVITIES**

U. S. DEPARTMENT OF TRANSPORTATION HOTLINE

Persons with knowledge of bid collusion (i.e., contractors, suppliers, workers, etc.) or other questionable contract related practices (inadequate materials, poor workmanship, theft of materials, etc.) are encouraged to report such activities by calling the U. S. D. O. T. HOTLINE. The HOTLINE number is 1-800-424-9071 and calls will be answered from 8:00 A.M. to 5:00 P.M. EST, Monday thru Friday. This HOTLINE is under the direction of the U.S.D.O.T.'s Inspector General. All information will be treated confidentially and the caller's anonymity will be respected.

NEW YORK STATE INSPECTOR GENERAL HOTLINE.

Reports of New York State Governmental Misconduct may be made in strict confidence to the New York State Inspector General on the Toll Free Statewide HOTLINE or by writing to the Office of the Inspector General. The Toll Free Statewide HOTLINE telephone number is 1-800-367-4448 and calls will be answered between 8:00 A.M. and 4:30 P.M., Monday through Friday. The address of the Office of the State Inspector General is the State Capitol, Executive Chamber, Albany, New York 12224.

DISADVANTAGED BUSINESS ENTERPRISE UTILIZATION GOALS

NEW YORK STATE DEPARTMENT OF TRANSPORTATION

DISADVANTAGED BUSINESS ENTERPRISE

UTILIZATION REQUIREMENTS

The Department has established the following Disadvantaged Business Enterprise (DBE) utilization goals for this contract. The goal is expressed as a percentage of the total bid price.

Disadvantaged Business Enterprise Utilization Goal 8 %

Information related to the current certification status of Disadvantaged Business Enterprises, can be obtained by contacting the:

NYS Department of Transportation
Office of Civil Rights
50 Wolf Road
POD 6-2
Albany, NY 12232
(518) 457-1128 or 457-1129

Disadvantaged Business Enterprise Officer

The Bidder shall designate and enter below the name of a Disadvantaged Business Enterprise Officer who will have the responsibility for and must be capable of effectively administering and promoting an active Disadvantaged Business Enterprise Program and who must be assigned adequate authority and responsibility to do so.

Bidder Designated DBE Officer _____
(Name, Title)

Telephone Number: _____

RETURN THIS PAGE WITH BID

1 OF 1

(This Page Intentionally Left Blank)

CERTIFICATION FOR FEDERAL AID CONTRACTS

The prospective participant certifies, by signing and submitting this bid or proposal, to the best of his/her knowledge and belief, that:

1. No Federal appropriated funds have been paid or will be paid, by or on behalf of the undersigned, to any person for influencing or attempting to influence an officer or employee of any Federal agency, a Member of Congress, an officer or employee of Congress, or an employee of a Member of Congress, in connection with the awarding of any Federal contract, the making of any Federal grant, the making of any Federal loan, the entering into of any cooperative agreement, and the extension, continuation, renewal, amendment, or modification of any Federal contract, grant, loan, or cooperative agreement.
2. If any funds other than Federal appropriated funds have been paid or will be paid to any person for influencing or attempting to influence an officer or employee of any Federal agency, a Member of Congress, an officer or employee of Congress, or an employee of a Member of Congress, in connection with this Federal contract, grant, loan, or cooperative agreement, the undersigned shall complete and submit Standard Form-LLL, "Disclosure Form to Report Lobbying", in accordance with its instructions.

This certification is a material representation of fact upon which reliance was placed when this transaction was made or entered into. Submission of this certification is a prerequisite for making or entering into this transaction imposed by Section 1352, Title 31, U. S. Code. Any person who fails to file the required certification shall be subject to a civil penalty of not less than \$10,000.00 and not more than \$100,000.00 for each such failure.

The prospective participant also agrees by submitting his/her bid or proposal that he/she shall require that the language of this certification be included in all lower tier subcontracts which exceed \$100,000.00 and that such sub recipients shall certify and disclose accordingly.

(This Page Intentionally Left Blank)

Iran Divestment Act

As a result of the Iran Divestment Act of 2012 (Act), Chapter 1 of the 2012 Laws of New York, a new provision has been added to the State Finance Law (SFL), § 165-a, effective April 12, 2012. Under the Act, the Commissioner of the Office of General Services (OGS) will be developing a list (prohibited entities list) of “persons” who are engaged in “investment activities in Iran” (both are defined terms in the law). Pursuant to SFL § 165-a(3)(b), the initial list is expected to be issued no later than 120 days after the Act’s effective date, at which time it will be posted on the OGS website.

By entering into this Contract, Contractor (or any assignee) certifies that once the prohibited entities list is posted on the OGS website, it will not utilize on such Contract any subcontractor that is identified on the prohibited entities list. Additionally, Contractor agrees that after the list is posted on the OGS website, should it seek to renew or extend the Contract, it will be required to certify at the time the Contract is renewed or extended that it is not included on the prohibited entities list. Contractor also agrees that any proposed Assignee of the Contract will be required to certify that it is not on the prohibited entities list before the New York State Department of Transportation (NYSDOT) may approve a request for Assignment of Contract.

During the term of the Contract, should NYSDOT receive information that a person is in violation of the above referenced certification, NYSDOT will offer the person an opportunity to respond. If the person fails to demonstrate that it has ceased its engagement in the investment which is in violation of the Act within 90 days after the determination of such violation, then NYSDOT shall take such action as may be appropriate including, but not limited to, imposing sanctions, seeking compliance, recovering damages, or declaring the Contractor in default.

NYSDOT reserves the right to reject any request for assignment for an entity that appears on the prohibited entities list prior to the award of a contract, and to pursue a responsibility review with respect to any entity that is awarded a contract and appears on the prohibited entities list after contract award.

Authorized Signature

Title

Date

Firm Name

CERTIFICATION OF EXPERIENCE

I, _____ HEREBY CERTIFY THAT (COMPANY _____
_____ HAS PERFORMED THE FOLLOWING WORK WITHING THE LAST THREE
YEARS **UNLESS SPECIFIED DIFFERENTLY IN THE SPECIFICATION:**

NAMES OF BUSINESS: _____ CONTACT NAME: _____

ADDRESS: _____

AMOUNT OF CONTRACT: _____ TELEPHONE NO.: _____

TYPE OF WORK: _____ FAX NO.: _____

NAMES OF BUSINESS: _____ CONTACT NAME: _____

ADDRESS: _____

AMOUNT OF CONTRACT: _____ TELEPHONE NO.: _____

TYPE OF WORK: _____ FAX NO.: _____

NAMES OF BUSINESS: _____ CONTACT NAME: _____

ADDRESS: _____

AMOUNT OF CONTRACT: _____ TELEPHONE NO.: _____

TYPE OF WORK: _____ FAX NO.: _____

NAMES OF BUSINESS: _____ CONTACT NAME: _____

ADDRESS: _____

AMOUNT OF CONTRACT: _____ TELEPHONE NO.: _____

TYPE OF WORK: _____ FAX NO.: _____

NAMES OF BUSINESS: _____ CONTACT NAME: _____

ADDRESS: _____

AMOUNT OF CONTRACT: _____ TELEPHONE NO.: _____

TYPE OF WORK: _____ FAX NO.: _____

NAMES OF BUSINESS: _____ CONTACT NAME: _____

ADDRESS: _____

AMOUNT OF CONTRACT: _____ TELEPHONE NO.: _____

TYPE OF WORK: _____ FAX NO.: _____

**ESSEX COUNTY
VENDOR RESPONSIBILITY QUESTIONNAIRE**

1. VENDOR IS: ____PRIME CONTRACTOR			
2. VENDOR'S LEGAL BUSINESS NAME		3. IDENTIFICATION NUMBERS A) FEIN # B) DUNS #	
4. D/B/A – Doing Business As (if applicable) & COUNTY FIELD		5. WEBSITE ADDRESS (if applicable)	
6. ADDRESS OF PRIMARY PLACE OF BUSINESS/EXECUTIVE OFFICE		7. TELEPHONE NUMBER	8. FAX NUMBER
9. ADDRESS OF PRIMARY PLACE OF BUSINESS/EXECUTIVE OFFICE <i>IN NEW YORK STATE, if different from above</i>		10. TELEPHONE NUMBER	11. FAX NUMBER
12. AUTHORIZED CONTACT FOR THIS QUESTIONNAIRE Name Title Telephone Number Fax Number Email			
13. LIST ALL OF THE VENDOR'S PRINCIPAL OWNERS			
A) NAME	TITLE	B) NAME	TITLE
C) NAME	TITLE	D) NAME	TITLE
A DETAILED EXPLANATION IS REQUIRED FOR EACH QUESTION ANSWERED WITH A "YES," AND MUST BE PROVIDED AS AN ATTACHMENT TO THE COMPLETED QUESTIONNAIRE. YOU MUST PROVIDE ADEQUATE DETAILS OR DOCUMENTS TO AID THE COUNTY IN MAKE A DETERMINATION OF VENDOR RESPONSIBILITY. PLEASE NUMBER EACH RESPONSE TO MATCH THE QUESTION NUMBER.			
14. DOES THE VENDOR USE, OR HAS IT USED IN THE PAST FIVE (5) YEARS, ANY OTHER BUSINESS NAME, FEIN, or D/B/A OTHER THAN THOSE LISTED IN ITEMS 2-4 ABOVE? List all other business name(s), Federal Employer Identification Number(s) or any D/B/A names and the dates that these names or numbers were/are in use. Explain the relationship to the vendor ___ YES ___ NO			
15. ARE THERE ANY INDIVIDUALS NOW SERVING IN A MANAGERIAL OR CONSULTING CAPACITY TO THE VENDOR, INCLUDING PRINCIPAL OWNERS AND OFFICERS, WHO NOW SERVE OR IN THE PAST ONE (1) YEARS HAVE SERVED AS: a) An elected or appointed public official or officer? <i>List each individual's name, business title, the name of the organization and position elected or appointed to, and dates of service</i> ___ YES ___ NO b) An officer of any political party organization in Essex County, whether paid or unpaid? <i>List each individuals name, business title or consulting capacity and the official political position held with applicable service dates.</i> ___ YES ___ NO			

16. WITHIN THE PAST (5) YEARS, HAS THE VENDOR, ANY INDIVIDUALS SERVING IN MANAGERIAL OR CONSULTING CAPACITY, PRINCIPAL, OWNERS, OFFICERS, MAJOR STOCKHOLDER(S) (10% OR MORE OF THE VOTING SHARES FOR PUBLICLY TRADED COMPANIES, 25% OR MORE OF THE SHARES FOR ALL OTHER COMPANIES), AFFILIATE OR ANY PERSON INVOLVED IN THE BIDDING OR CONTRACTING PROCESS:

- a) 1. been suspended, debarred or terminated by a local, state or federal authority in connection with a contract or contracting process; ___ YES ___ NO
- 2. been disqualified for cause as a bidder on any permit, license, concession, franchise or lease;
- 3. entered into an agreement to a voluntary exclusion from bidding/contracting;
- 4. had a bid rejected on an Essex County contract for failure to comply with the MacBride Fair Employment Principles;
- 5. had a low bid rejected on a local, state or federal contract for failure to meet statutory affirmative action or M/WBE requirements on a previously held contract;
- 6. had a status as a Women's Business Enterprise, Minority Business Enterprise or Disadvantaged Business Enterprise, de-certified, revoked or forfeited;
- 7. been subject to an administrative proceeding or civil action seeking specific performance or restitution in connection with any local, state or federal government contract;
- 8. been denied an award of a local, state or federal government contract, had a contract suspended or had a contract terminated for non-responsibility; or
- 9. had a local, state or federal government contract suspended or terminated for cause prior to the completion of the term of the contract.
- b) been indicted, convicted, received a judgment against them or a grant of immunity for any business-related conduct constituting a crime under local, state or federal law including but not limited to, fraud, extortion, bribery, racketeering, price-fixing, bid collusion or any crime related to truthfulness and/or business conduct? ___ YES ___ NO
- c) been issued a citation, notice, violation order, or are pending an administrative hearing or proceeding or determination of violations of: ___ YES ___ NO
 - 1. federal, state or local health laws, rules or regulations

17. IN THE PAST THREE (3) YEARS, HAS THE VENDOR OR ITS AFFILIATES' HAD ANY CLAIMS, JUDGMENTS, INJUNCTIONS, LIENS, FINES OR PENALTIES SECURED BY ANY GOVERNMENTAL AGENCY? Indicate if this is applicable to the submitting vendor or affiliate. State whether the situation(s) was a claim, judgment, injunction, lien or other with an explanation. Provide the name(s) and address(es) of the agency, the amount of the original obligation and outstanding balance. If any of these items are open, unsatisfied, indicate the status of each items as "open" or "unsatisfied". ___ YES ___ NO

18. DURING THE PAST THREE (3) YEARS, HAS THE VENDOR FAILED TO:

- a) file returns or pay any applicable federal, state or city taxes?
Identify the taxing jurisdiction, type of tax, liability year(s), and tax liability amount the vendor failed to file/pay and the current status of the liability. ___ YES ___ NO
- b) file returns or pay New York State unemployment insurance?
Indicate the years the vendor failed to file/pay the insurance and the current status of the liability. ___ YES ___ NO
- c) Property Tax
Indicate the years the vendor failed to file. ___ YES ___ NO

19. HAVE ANY BANKRUPTCY PROCEEDINGS BEEN INITIATED BY OR AGAINST THE VENDOR OR ITS AFFILIATES' WITHIN THE PAST SEVEN (7) YEARS (WHETHER OR NOT CLOSED) OR IS ANY BANKRUPTCY PROCEEDING PENDING BY OR AGAINST THE VENDOR OR ITS AFFILIATES REGARDLESS OF THE DATE OF FILING? ___ YES ___ NO

Indicate if this is applicable to the submitting vendor or affiliate. If it is an affiliate, include the affiliate's name and FEIN. Provide the court name, address and docket number. Indicate if the proceedings have been initiated, remain pending or have been closed. If closed, provide the date closed.

20. IS THE VENDOR CURRENTLY INSOLVENT, OR DOES VENDOR CURRENTLY HAVE REASON TO BELIEVE THAT AN INVOLUNTARY BANKRUPTCY PROCEEDING MAY BE BROUGHT AGAINST IT? _____ YES _____ NO
Provide financial information to support the vendor's current position, for example, Current Ration, Debt Ration, Age of Accounts Payable, Cash Flow and any documents that will provide the agency with an understanding of the vendor's situation.

21. IN THE PAST FIVE (5) YEARS, HAS THE VENDOR OR ANY AFFILIATES:
a) defaulted or been terminated on, or had its surety called upon to complete, any contract (public or private) awarded; _____ YES _____ NO
Indicate if this is applicable to the submitting vendor or affiliate. Detail the situation(s) that gave rise to the negative action, any corrective action taken by the vendor and the name of the contracting agency.

¹ "Affiliate" meaning: (a) any entity in which the vendor owns more than 50% of the voting stock; (b) any individual, entity or group of principal owners or officers who own more than 50% of the voting stock of the vendor; or (c) any entity whose voting stock is more than 50% owned by the same individual, entity or group described in clause (b). In addition, if a vendor owns less than 50% of the voting stock of another entity, but directs or has the right to direct such entity's daily operations, that entity will be an "affiliate" for purposes of this questionnaire.

**ESSEX COUNTY
VENDOR RESPONSIBILITY QUESTIONNAIRE**

FEIN # _____

State of:)
) ss:
County of:)

CERTIFICATION:

The undersigned: recognizes that this questionnaire is submitted for the express purpose of assisting the County of Essex in making a determination regarding an award of contract or approval of a subcontract; acknowledges that the County may in its discretion, by means which it may choose, verify the truth and accuracy of all statements made herein; acknowledges that intentional submission of false or misleading information may constitute a felony under Penal Law Section 210.40 or a misdemeanor under Penal Law Section 210.35 or Section 210.45, and may also be punishable by a fine and/or imprisonment of up to five years under 18 USC Section 1001 and may result in contract termination; and states that the information submitted in this questionnaire and any attached pages is true, accurate and complete.

The undersigned certifies that he/she:

- Has not altered the content of the questions in the questionnaire in any manner;
- Has read and understands all of the items contained in the questionnaire and any pages attached by the submitting vendor;
- Has supplied full and complete responses to each item therein to the best of his/her knowledge, information and belief;
- Is knowledgeable about the submitting vendor's business and operations;
- Understands that Essex County will rely on the information supplied in the questionnaire when entering into a contract with the vendor;
- Is under duty to notify the Essex County Purchasing Officer of any changes to the vendor's responses.

Name of Business: _____

Signature of Owner: _____

Printed Name of Signatory: _____

Title: _____

Address: _____ City, State, Zip: _____

Date: _____

Sworn before me this _____ day of
_____, 20____

Notary Public

Request for Taxpayer Identification Number and Certification

**Give Form to the
requester. Do not
send to the IRS.**

Print or type See Specific Instructions on page 2.	1 Name (as shown on your income tax return). Name is required on this line; do not leave this line blank.	
	2 Business name/disregarded entity name, if different from above	
	3 Check appropriate box for federal tax classification; check only one of the following seven boxes: <input type="checkbox"/> Individual/sole proprietor or single-member LLC <input type="checkbox"/> C Corporation <input type="checkbox"/> S Corporation <input type="checkbox"/> Partnership <input type="checkbox"/> Trust/estate <input type="checkbox"/> Limited liability company. Enter the tax classification (C=C corporation, S=S corporation, P=partnership) ▶ _____ Note. For a single-member LLC that is disregarded, do not check LLC; check the appropriate box in the line above for the tax classification of the single-member owner. <input type="checkbox"/> Other (see instructions) ▶ _____	
	4 Exemptions (codes apply only to certain entities, not individuals; see instructions on page 3): Exempt payee code (if any) _____ Exemption from FATCA reporting code (if any) _____ <i>(Applies to accounts maintained outside the U.S.)</i>	
	5 Address (number, street, and apt. or suite no.)	
	6 City, state, and ZIP code	
	7 List account number(s) here (optional)	

Requester's name and address (optional)

Part I Taxpayer Identification Number (TIN)

Enter your TIN in the appropriate box. The TIN provided must match the name given on line 1 to avoid backup withholding. For individuals, this is generally your social security number (SSN). However, for a resident alien, sole proprietor, or disregarded entity, see the Part I instructions on page 3. For other entities, it is your employer identification number (EIN). If you do not have a number, see *How to get a TIN* on page 3.

Note. If the account is in more than one name, see the instructions for line 1 and the chart on page 4 for guidelines on whose number to enter.

Social security number												
				-				-				
OR												
Employer identification number												
				-								

Part II Certification

Under penalties of perjury, I certify that:

1. The number shown on this form is my correct taxpayer identification number (or I am waiting for a number to be issued to me); and
2. I am not subject to backup withholding because: (a) I am exempt from backup withholding, or (b) I have not been notified by the Internal Revenue Service (IRS) that I am subject to backup withholding as a result of a failure to report all interest or dividends, or (c) the IRS has notified me that I am no longer subject to backup withholding; and
3. I am a U.S. citizen or other U.S. person (defined below); and
4. The FATCA code(s) entered on this form (if any) indicating that I am exempt from FATCA reporting is correct.

Certification instructions. You must cross out item 2 above if you have been notified by the IRS that you are currently subject to backup withholding because you have failed to report all interest and dividends on your tax return. For real estate transactions, item 2 does not apply. For mortgage interest paid, acquisition or abandonment of secured property, cancellation of debt, contributions to an individual retirement arrangement (IRA), and generally, payments other than interest and dividends, you are not required to sign the certification, but you must provide your correct TIN. See the instructions on page 3.

Sign Here	Signature of U.S. person ▶	Date ▶
------------------	----------------------------	--------

General Instructions

Section references are to the Internal Revenue Code unless otherwise noted.
Future developments. Information about developments affecting Form W-9 (such as legislation enacted after we release it) is at www.irs.gov/fw9.

Purpose of Form

An individual or entity (Form W-9 requester) who is required to file an information return with the IRS must obtain your correct taxpayer identification number (TIN) which may be your social security number (SSN), individual taxpayer identification number (ITIN), adoption taxpayer identification number (ATIN), or employer identification number (EIN), to report on an information return the amount paid to you, or other amount reportable on an information return. Examples of information returns include, but are not limited to, the following:

- Form 1099-INT (interest earned or paid)
- Form 1099-DIV (dividends, including those from stocks or mutual funds)
- Form 1099-MISC (various types of income, prizes, awards, or gross proceeds)
- Form 1099-B (stock or mutual fund sales and certain other transactions by brokers)
- Form 1099-S (proceeds from real estate transactions)
- Form 1099-K (merchant card and third party network transactions)

- Form 1098 (home mortgage interest), 1098-E (student loan interest), 1098-T (tuition)
- Form 1099-C (canceled debt)
- Form 1099-A (acquisition or abandonment of secured property)

Use Form W-9 only if you are a U.S. person (including a resident alien), to provide your correct TIN.

If you do not return Form W-9 to the requester with a TIN, you might be subject to backup withholding. See What is backup withholding? on page 2.

By signing the filled-out form, you:

1. Certify that the TIN you are giving is correct (or you are waiting for a number to be issued),
2. Certify that you are not subject to backup withholding, or
3. Claim exemption from backup withholding if you are a U.S. exempt payee. If applicable, you are also certifying that as a U.S. person, your allocable share of any partnership income from a U.S. trade or business is not subject to the withholding tax on foreign partners' share of effectively connected income, and
4. Certify that FATCA code(s) entered on this form (if any) indicating that you are exempt from the FATCA reporting, is correct. See *What is FATCA reporting?* on page 2 for further information.

Note. If you are a U.S. person and a requester gives you a form other than Form W-9 to request your TIN, you must use the requester's form if it is substantially similar to this Form W-9.

Definition of a U.S. person. For federal tax purposes, you are considered a U.S. person if you are:

- An individual who is a U.S. citizen or U.S. resident alien;
- A partnership, corporation, company, or association created or organized in the United States or under the laws of the United States;
- An estate (other than a foreign estate); or
- A domestic trust (as defined in Regulations section 301.7701-7).

Special rules for partnerships. Partnerships that conduct a trade or business in the United States are generally required to pay a withholding tax under section 1446 on any foreign partners' share of effectively connected taxable income from such business. Further, in certain cases where a Form W-9 has not been received, the rules under section 1446 require a partnership to presume that a partner is a foreign person, and pay the section 1446 withholding tax. Therefore, if you are a U.S. person that is a partner in a partnership conducting a trade or business in the United States, provide Form W-9 to the partnership to establish your U.S. status and avoid section 1446 withholding on your share of partnership income.

In the cases below, the following person must give Form W-9 to the partnership for purposes of establishing its U.S. status and avoiding withholding on its allocable share of net income from the partnership conducting a trade or business in the United States:

- In the case of a disregarded entity with a U.S. owner, the U.S. owner of the disregarded entity and not the entity;
- In the case of a grantor trust with a U.S. grantor or other U.S. owner, generally, the U.S. grantor or other U.S. owner of the grantor trust and not the trust; and
- In the case of a U.S. trust (other than a grantor trust), the U.S. trust (other than a grantor trust) and not the beneficiaries of the trust.

Foreign person. If you are a foreign person or the U.S. branch of a foreign bank that has elected to be treated as a U.S. person, do not use Form W-9. Instead, use the appropriate Form W-8 or Form 8233 (see Publication 515, Withholding of Tax on Nonresident Aliens and Foreign Entities).

Nonresident alien who becomes a resident alien. Generally, only a nonresident alien individual may use the terms of a tax treaty to reduce or eliminate U.S. tax on certain types of income. However, most tax treaties contain a provision known as a "saving clause." Exceptions specified in the saving clause may permit an exemption from tax to continue for certain types of income even after the payee has otherwise become a U.S. resident alien for tax purposes.

If you are a U.S. resident alien who is relying on an exception contained in the saving clause of a tax treaty to claim an exemption from U.S. tax on certain types of income, you must attach a statement to Form W-9 that specifies the following five items:

1. The treaty country. Generally, this must be the same treaty under which you claimed exemption from tax as a nonresident alien.
2. The treaty article addressing the income.
3. The article number (or location) in the tax treaty that contains the saving clause and its exceptions.
4. The type and amount of income that qualifies for the exemption from tax.
5. Sufficient facts to justify the exemption from tax under the terms of the treaty article.

Example. Article 20 of the U.S.-China income tax treaty allows an exemption from tax for scholarship income received by a Chinese student temporarily present in the United States. Under U.S. law, this student will become a resident alien for tax purposes if his or her stay in the United States exceeds 5 calendar years. However, paragraph 2 of the first Protocol to the U.S.-China treaty (dated April 30, 1984) allows the provisions of Article 20 to continue to apply even after the Chinese student becomes a resident alien of the United States. A Chinese student who qualifies for this exception (under paragraph 2 of the first protocol) and is relying on this exception to claim an exemption from tax on his or her scholarship or fellowship income would attach to Form W-9 a statement that includes the information described above to support that exemption.

If you are a nonresident alien or a foreign entity, give the requester the appropriate completed Form W-8 or Form 8233.

Backup Withholding

What is backup withholding? Persons making certain payments to you must under certain conditions withhold and pay to the IRS 28% of such payments. This is called "backup withholding." Payments that may be subject to backup withholding include interest, tax-exempt interest, dividends, broker and barter exchange transactions, rents, royalties, nonemployee pay, payments made in settlement of payment card and third party network transactions, and certain payments from fishing boat operators. Real estate transactions are not subject to backup withholding.

You will not be subject to backup withholding on payments you receive if you give the requester your correct TIN, make the proper certifications, and report all your taxable interest and dividends on your tax return.

Payments you receive will be subject to backup withholding if:

1. You do not furnish your TIN to the requester,
2. You do not certify your TIN when required (see the Part II instructions on page 3 for details),

3. The IRS tells the requester that you furnished an incorrect TIN,

4. The IRS tells you that you are subject to backup withholding because you did not report all your interest and dividends on your tax return (for reportable interest and dividends only), or

5. You do not certify to the requester that you are not subject to backup withholding under 4 above (for reportable interest and dividend accounts opened after 1983 only).

Certain payees and payments are exempt from backup withholding. See *Exempt payee code* on page 3 and the separate Instructions for the Requester of Form W-9 for more information.

Also see *Special rules for partnerships* above.

What is FATCA reporting?

The Foreign Account Tax Compliance Act (FATCA) requires a participating foreign financial institution to report all United States account holders that are specified United States persons. Certain payees are exempt from FATCA reporting. See *Exemption from FATCA reporting code* on page 3 and the Instructions for the Requester of Form W-9 for more information.

Updating Your Information

You must provide updated information to any person to whom you claimed to be an exempt payee if you are no longer an exempt payee and anticipate receiving reportable payments in the future from this person. For example, you may need to provide updated information if you are a C corporation that elects to be an S corporation, or if you no longer are tax exempt. In addition, you must furnish a new Form W-9 if the name or TIN changes for the account; for example, if the grantor of a grantor trust dies.

Penalties

Failure to furnish TIN. If you fail to furnish your correct TIN to a requester, you are subject to a penalty of \$50 for each such failure unless your failure is due to reasonable cause and not to willful neglect.

Civil penalty for false information with respect to withholding. If you make a false statement with no reasonable basis that results in no backup withholding, you are subject to a \$500 penalty.

Criminal penalty for falsifying information. Willfully falsifying certifications or affirmations may subject you to criminal penalties including fines and/or imprisonment.

Misuse of TINs. If the requester discloses or uses TINs in violation of federal law, the requester may be subject to civil and criminal penalties.

Specific Instructions

Line 1

You must enter one of the following on this line; **do not** leave this line blank. The name should match the name on your tax return.

If this Form W-9 is for a joint account, list first, and then circle, the name of the person or entity whose number you entered in Part I of Form W-9.

a. **Individual.** Generally, enter the name shown on your tax return. If you have changed your last name without informing the Social Security Administration (SSA) of the name change, enter your first name, the last name as shown on your social security card, and your new last name.

Note. ITIN applicant: Enter your individual name as it was entered on your Form W-7 application, line 1a. This should also be the same as the name you entered on the Form 1040/1040A/1040EZ you filed with your application.

b. **Sole proprietor or single-member LLC.** Enter your individual name as shown on your 1040/1040A/1040EZ on line 1. You may enter your business, trade, or "doing business as" (DBA) name on line 2.

c. **Partnership, LLC that is not a single-member LLC, C Corporation, or S Corporation.** Enter the entity's name as shown on the entity's tax return on line 1 and any business, trade, or DBA name on line 2.

d. **Other entities.** Enter your name as shown on required U.S. federal tax documents on line 1. This name should match the name shown on the charter or other legal document creating the entity. You may enter any business, trade, or DBA name on line 2.

e. **Disregarded entity.** For U.S. federal tax purposes, an entity that is disregarded as an entity separate from its owner is treated as a "disregarded entity." See Regulations section 301.7701-2(c)(2)(iii). Enter the owner's name on line 1. The name of the entity entered on line 1 should never be a disregarded entity. The name on line 1 should be the name shown on the income tax return on which the income should be reported. For example, if a foreign LLC that is treated as a disregarded entity for U.S. federal tax purposes has a single owner that is a U.S. person, the U.S. owner's name is required to be provided on line 1. If the direct owner of the entity is also a disregarded entity, enter the first owner that is not disregarded for federal tax purposes. Enter the disregarded entity's name on line 2, "Business name/disregarded entity name." If the owner of the disregarded entity is a foreign person, the owner must complete an appropriate Form W-8 instead of a Form W-9. This is the case even if the foreign person has a U.S. TIN.

Line 2

If you have a business name, trade name, DBA name, or disregarded entity name, you may enter it on line 2.

Line 3

Check the appropriate box in line 3 for the U.S. federal tax classification of the person whose name is entered on line 1. Check only one box in line 3.

Limited Liability Company (LLC). If the name on line 1 is an LLC treated as a partnership for U.S. federal tax purposes, check the "Limited Liability Company" box and enter "P" in the space provided. If the LLC has filed Form 8832 or 2553 to be taxed as a corporation, check the "Limited Liability Company" box and in the space provided enter "C" for C corporation or "S" for S corporation. If it is a single-member LLC that is a disregarded entity, do not check the "Limited Liability Company" box; instead check the first box in line 3 "Individual/sole proprietor or single-member LLC."

Line 4, Exemptions

If you are exempt from backup withholding and/or FATCA reporting, enter in the appropriate space in line 4 any code(s) that may apply to you.

Exempt payee code.

- Generally, individuals (including sole proprietors) are not exempt from backup withholding.
- Except as provided below, corporations are exempt from backup withholding for certain payments, including interest and dividends.
- Corporations are not exempt from backup withholding for payments made in settlement of payment card or third party network transactions.
- Corporations are not exempt from backup withholding with respect to attorneys' fees or gross proceeds paid to attorneys, and corporations that provide medical or health care services are not exempt with respect to payments reportable on Form 1099-MISC.

The following codes identify payees that are exempt from backup withholding. Enter the appropriate code in the space in line 4.

- 1—An organization exempt from tax under section 501(a), any IRA, or a custodial account under section 403(b)(7) if the account satisfies the requirements of section 401(f)(2)
- 2—The United States or any of its agencies or instrumentalities
- 3—A state, the District of Columbia, a U.S. commonwealth or possession, or any of their political subdivisions or instrumentalities
- 4—A foreign government or any of its political subdivisions, agencies, or instrumentalities
- 5—A corporation
- 6—A dealer in securities or commodities required to register in the United States, the District of Columbia, or a U.S. commonwealth or possession
- 7—A futures commission merchant registered with the Commodity Futures Trading Commission
- 8—A real estate investment trust
- 9—An entity registered at all times during the tax year under the Investment Company Act of 1940
- 10—A common trust fund operated by a bank under section 584(a)
- 11—A financial institution
- 12—A middleman known in the investment community as a nominee or custodian
- 13—A trust exempt from tax under section 664 or described in section 4947

The following chart shows types of payments that may be exempt from backup withholding. The chart applies to the exempt payees listed above, 1 through 13.

IF the payment is for . . .	THEN the payment is exempt for . . .
Interest and dividend payments	All exempt payees except for 7
Broker transactions	Exempt payees 1 through 4 and 6 through 11 and all C corporations. S corporations must not enter an exempt payee code because they are exempt only for sales of noncovered securities acquired prior to 2012.
Barter exchange transactions and patronage dividends	Exempt payees 1 through 4
Payments over \$600 required to be reported and direct sales over \$5,000 ¹	Generally, exempt payees 1 through 5 ²
Payments made in settlement of payment card or third party network transactions	Exempt payees 1 through 4

¹See Form 1099-MISC, Miscellaneous Income, and its instructions.

²However, the following payments made to a corporation and reportable on Form 1099-MISC are not exempt from backup withholding: medical and health care payments, attorneys' fees, gross proceeds paid to an attorney reportable under section 6045(f), and payments for services paid by a federal executive agency.

Exemption from FATCA reporting code. The following codes identify payees that are exempt from reporting under FATCA. These codes apply to persons submitting this form for accounts maintained outside of the United States by certain foreign financial institutions. Therefore, if you are only submitting this form for an account you hold in the United States, you may leave this field blank. Consult with the person requesting this form if you are uncertain if the financial institution is subject to these requirements. A requester may indicate that a code is not required by providing you with a Form W-9 with "Not Applicable" (or any similar indication) written or printed on the line for a FATCA exemption code.

A—An organization exempt from tax under section 501(a) or any individual retirement plan as defined in section 7701(a)(37)

B—The United States or any of its agencies or instrumentalities

C—A state, the District of Columbia, a U.S. commonwealth or possession, or any of their political subdivisions or instrumentalities

D—A corporation the stock of which is regularly traded on one or more established securities markets, as described in Regulations section 1.1472-1(c)(1)(i)

E—A corporation that is a member of the same expanded affiliated group as a corporation described in Regulations section 1.1472-1(c)(1)(i)

F—A dealer in securities, commodities, or derivative financial instruments (including notional principal contracts, futures, forwards, and options) that is registered as such under the laws of the United States or any state

G—A real estate investment trust

H—A regulated investment company as defined in section 851 or an entity registered at all times during the tax year under the Investment Company Act of 1940

I—A common trust fund as defined in section 584(a)

J—A bank as defined in section 581

K—A broker

L—A trust exempt from tax under section 664 or described in section 4947(a)(1)

M—A tax exempt trust under a section 403(b) plan or section 457(g) plan

Note. You may wish to consult with the financial institution requesting this form to determine whether the FATCA code and/or exempt payee code should be completed.

Line 5

Enter your address (number, street, and apartment or suite number). This is where the requester of this Form W-9 will mail your information returns.

Line 6

Enter your city, state, and ZIP code.

Part I. Taxpayer Identification Number (TIN)

Enter your TIN in the appropriate box. If you are a resident alien and you do not have and are not eligible to get an SSN, your TIN is your IRS individual taxpayer identification number (ITIN). Enter it in the social security number box. If you do not have an ITIN, see *How to get a TIN* below.

If you are a sole proprietor and you have an EIN, you may enter either your SSN or EIN. However, the IRS prefers that you use your SSN.

If you are a single-member LLC that is disregarded as an entity separate from its owner (see *Limited Liability Company (LLC)* on this page), enter the owner's SSN (or EIN, if the owner has one). Do not enter the disregarded entity's EIN. If the LLC is classified as a corporation or partnership, enter the entity's EIN.

Note. See the chart on page 4 for further clarification of name and TIN combinations.

How to get a TIN. If you do not have a TIN, apply for one immediately. To apply for an SSN, get Form SS-5, Application for a Social Security Card, from your local SSA office or get this form online at www.ssa.gov. You may also get this form by calling 1-800-772-1213. Use Form W-7, Application for IRS Individual Taxpayer Identification Number, to apply for an ITIN, or Form SS-4, Application for Employer Identification Number, to apply for an EIN. You can apply for an EIN online by accessing the IRS website at www.irs.gov/businesses and clicking on Employer Identification Number (EIN) under Starting a Business. You can get Forms W-7 and SS-4 from the IRS by visiting IRS.gov or by calling 1-800-TAX-FORM (1-800-829-3676).

If you are asked to complete Form W-9 but do not have a TIN, apply for a TIN and write "Applied For" in the space for the TIN, sign and date the form, and give it to the requester. For interest and dividend payments, and certain payments made with respect to readily tradable instruments, generally you will have 60 days to get a TIN and give it to the requester before you are subject to backup withholding on payments. The 60-day rule does not apply to other types of payments. You will be subject to backup withholding on all such payments until you provide your TIN to the requester.

Note. Entering "Applied For" means that you have already applied for a TIN or that you intend to apply for one soon.

Caution: A disregarded U.S. entity that has a foreign owner must use the appropriate Form W-8.

Part II. Certification

To establish to the withholding agent that you are a U.S. person, or resident alien, sign Form W-9. You may be requested to sign by the withholding agent even if items 1, 4, or 5 below indicate otherwise.

For a joint account, only the person whose TIN is shown in Part I should sign (when required). In the case of a disregarded entity, the person identified on line 1 must sign. Exempt payees, see *Exempt payee code* earlier.

Signature requirements. Complete the certification as indicated in items 1 through 5 below.

- 1. Interest, dividend, and barter exchange accounts opened before 1984 and broker accounts considered active during 1983.** You must give your correct TIN, but you do not have to sign the certification.
- 2. Interest, dividend, broker, and barter exchange accounts opened after 1983 and broker accounts considered inactive during 1983.** You must sign the certification or backup withholding will apply. If you are subject to backup withholding and you are merely providing your correct TIN to the requester, you must cross out item 2 in the certification before signing the form.
- 3. Real estate transactions.** You must sign the certification. You may cross out item 2 of the certification.
- 4. Other payments.** You must give your correct TIN, but you do not have to sign the certification unless you have been notified that you have previously given an incorrect TIN. "Other payments" include payments made in the course of the requester's trade or business for rents, royalties, goods (other than bills for merchandise), medical and health care services (including payments to corporations), payments to a nonemployee for services, payments made in settlement of payment card and third party network transactions, payments to certain fishing boat crew members and fishermen, and gross proceeds paid to attorneys (including payments to corporations).
- 5. Mortgage interest paid by you, acquisition or abandonment of secured property, cancellation of debt, qualified tuition program payments (under section 529), IRA, Coverdell ESA, Archer MSA or HSA contributions or distributions, and pension distributions.** You must give your correct TIN, but you do not have to sign the certification.

What Name and Number To Give the Requester

For this type of account:	Give name and SSN of:
1. Individual	The individual
2. Two or more individuals (joint account)	The actual owner of the account or, if combined funds, the first individual on the account ¹
3. Custodian account of a minor (Uniform Gift to Minors Act)	The minor ²
4. a. The usual revocable savings trust (grantor is also trustee) b. So-called trust account that is not a legal or valid trust under state law	The grantor-trustee ¹ The actual owner ¹
5. Sole proprietorship or disregarded entity owned by an individual	The owner ³
6. Grantor trust filing under Optional Form 1099 Filing Method 1 (see Regulations section 1.671-4(b)(2)(i)(A))	The grantor*
For this type of account:	Give name and EIN of:
7. Disregarded entity not owned by an individual	The owner
8. A valid trust, estate, or pension trust	Legal entity ⁴
9. Corporation or LLC electing corporate status on Form 8832 or Form 2553	The corporation
10. Association, club, religious, charitable, educational, or other tax-exempt organization	The organization
11. Partnership or multi-member LLC	The partnership
12. A broker or registered nominee	The broker or nominee
13. Account with the Department of Agriculture in the name of a public entity (such as a state or local government, school district, or prison) that receives agricultural program payments	The public entity
14. Grantor trust filing under the Form 1041 Filing Method or the Optional Form 1099 Filing Method 2 (see Regulations section 1.671-4(b)(2)(i)(B))	The trust

¹ List first and circle the name of the person whose number you furnish. If only one person on a joint account has an SSN, that person's number must be furnished.

² Circle the minor's name and furnish the minor's SSN.

³ You must show your individual name and you may also enter your business or DBA name on the "Business name/disregarded entity" name line. You may use either your SSN or EIN (if you have one), but the IRS encourages you to use your SSN.

⁴ List first and circle the name of the trust, estate, or pension trust. (Do not furnish the TIN of the personal representative or trustee unless the legal entity itself is not designated in the account title.) Also see *Special rules for partnerships* on page 2.

*Note. Grantor also must provide a Form W-9 to trustee of trust.

Note. If no name is circled when more than one name is listed, the number will be considered to be that of the first name listed.

Secure Your Tax Records from Identity Theft

Identity theft occurs when someone uses your personal information such as your name, SSN, or other identifying information, without your permission, to commit fraud or other crimes. An identity thief may use your SSN to get a job or may file a tax return using your SSN to receive a refund.

To reduce your risk:

- Protect your SSN,
- Ensure your employer is protecting your SSN, and
- Be careful when choosing a tax preparer.

If your tax records are affected by identity theft and you receive a notice from the IRS, respond right away to the name and phone number printed on the IRS notice or letter.

If your tax records are not currently affected by identity theft but you think you are at risk due to a lost or stolen purse or wallet, questionable credit card activity or credit report, contact the IRS Identity Theft Hotline at 1-800-908-4490 or submit Form 14039.

For more information, see Publication 4535, Identity Theft Prevention and Victim Assistance.

Victims of identity theft who are experiencing economic harm or a system problem, or are seeking help in resolving tax problems that have not been resolved through normal channels, may be eligible for Taxpayer Advocate Service (TAS) assistance. You can reach TAS by calling the TAS toll-free case intake line at 1-877-777-4778 or TTY/TDD 1-800-829-4059.

Protect yourself from suspicious emails or phishing schemes. Phishing is the creation and use of email and websites designed to mimic legitimate business emails and websites. The most common act is sending an email to a user falsely claiming to be an established legitimate enterprise in an attempt to scam the user into surrendering private information that will be used for identity theft.

The IRS does not initiate contacts with taxpayers via emails. Also, the IRS does not request personal detailed information through email or ask taxpayers for the PIN numbers, passwords, or similar secret access information for their credit card, bank, or other financial accounts.

If you receive an unsolicited email claiming to be from the IRS, forward this message to phishing@irs.gov. You may also report misuse of the IRS name, logo, or other IRS property to the Treasury Inspector General for Tax Administration (TIGTA) at 1-800-366-4484. You can forward suspicious emails to the Federal Trade Commission at: spam@uce.gov or contact them at www.ftc.gov/idtheft or 1-877-IDTHEFT (1-877-438-4338).

Visit IRS.gov to learn more about identity theft and how to reduce your risk.

Privacy Act Notice

Section 6109 of the Internal Revenue Code requires you to provide your correct TIN to persons (including federal agencies) who are required to file information returns with the IRS to report interest, dividends, or certain other income paid to you; mortgage interest you paid; the acquisition or abandonment of secured property; the cancellation of debt; or contributions you made to an IRA, Archer MSA, or HSA. The person collecting this form uses the information on the form to file information returns with the IRS, reporting the above information. Routine uses of this information include giving it to the Department of Justice for civil and criminal litigation and to cities, states, the District of Columbia, and U.S. commonwealths and possessions for use in administering their laws. The information also may be disclosed to other countries under a treaty, to federal and state agencies to enforce civil and criminal laws, or to federal law enforcement and intelligence agencies to combat terrorism. You must provide your TIN whether or not you are required to file a tax return. Under section 3406, payers must generally withhold a percentage of taxable interest, dividend, and certain other payments to a payee who does not give a TIN to the payer. Certain penalties may also apply for providing false or fraudulent information.

Sexual Harassment Training

As a result of the enactment of anti-sexual harassment legislation, a new provision has been added to the State Finance Law (SFL), § 139-L, effective April 12, 2018. Under the legislation, Bidders/Proposers must certify as part of their bid that they are in compliance with maintaining a written policy addressing sexual harassment prevention in the workplace and providing annual sexual harassment prevention training to all their employees.

By submission of this bid, each bidder and each person signing on behalf of any bidder certifies, and in the case of a joint bid each party thereto certifies as to its own organization, under penalty of perjury, that the bidder has and has implemented a written policy addressing sexual harassment prevention in the workplace and provides annual sexual harassment prevention training to all of its employees. Such policy shall, at a minimum, meet the requirements of section two hundred one-g of the New York State Labor Law.

Authorized Signature

Title

Date

Firm Name

(This Page Intentionally Left Blank)

**STANDARD FORM OF AGREEMENT
BETWEEN OWNER AND CONTRACTOR
ON THE BASIS OF A STIPULATED PRICE**

THIS AGREEMENT is dated as of the _____ day of _____ in the year
2019 by and between _____ the County of Essex _____ (hereinafter called OWNER) and
_____ (hereinafter called CONTRACTOR).

OWNER and CONTRACTOR, in consideration of the mutual covenants hereinafter set forth, agree as follows:

Article 1 WORK.

CONTRACTOR shall complete all Work as specified or indicated in the Contract Documents. The Work is generally described as follows:

Campsite Road over the Hudson River
Bridge Replacement – PIN 1760.68
Town of Newcomb, Essex County, New York

Article 2 ENGINEER.

The Project has been designed by Creighton Manning Engineering, LLP, 2 Winners Circle, Albany, New York 12205. The ENGINEER will act as OWNER's representative, and will assume all duties and responsibilities, and have the rights and authority assigned to ENGINEER in the Contract Documents in connection with completion of the Work in accordance with the Contract Documents.

Article 3 CONTRACT TIMES.

3.1 The Work will be substantially completed with the new bridge open to traffic by November 20, 2019, and completed and ready for final payment by June 30, 2020.

3.2 *Liquidated Damages.* OWNER and CONTRACTOR recognize that time is of the essence of this Agreement and that OWNER will suffer financial loss if the Work is not completed within the times specified in paragraph 3.1 above, plus any extensions thereof allowed in accordance with the NYSDOT Standard Specifications. They also recognize the delays, expense and difficulties involved in proving the actual loss suffered by OWNER if the Work is not completed on time. Accordingly, instead of requiring of such proof, OWNER and CONTRACTOR agree that as liquidated damages for delay (but not as a penalty), CONTRACTOR shall pay OWNER One Thousand Five Hundred Dollars (\$1,500.00) for each day that expires after the time specified in paragraph 3.1 for Substantial Completion until the Work is substantially complete. After Substantial Completion, if CONTRACTOR shall neglect, refuse, or fail to complete the remaining Work within the time specified in paragraph 3.1 for completion and readiness for final payment or any proper extension thereof granted by OWNER, CONTRACTOR shall pay OWNER One Thousand Five Hundred dollars (\$1,500.00) for each day that expires after the time specified in paragraph 3.1 for completion and readiness for final payment. This is not assessed as a penalty, but as liquidated damages for prolonged inconvenience accruing to the highway user and the locality.

Article 4 CONTRACT PRICE

4.1 OWNER shall pay CONTRACTOR for performance of the Work in accordance with the Contract documents in current funds, the sum of _____ Dollars (\$ _____), being the gross sum bid, obtained from the summation of the products of the approximate quantities multiplied by the unit prices bid.

4.2 Contractor agrees to accept the unit prices bid as compensation for any additions or deductions caused by variation in quantities due to more accurate measurement or due to actual field conditions, and for use in the computation of the value of the Work performed for monthly estimates.

4.3 The Final Contract Price shall be the amount obtained from the summation of the products of the quantities of Work as done multiplied by the unit prices bid.

4.4 Contractor's Bid is attached to and is a part of this Agreement.

4.5 Contractor further agrees that at any time during the progress of Work, extra and/or force account Work is required, he shall so perform such Work and accept compensation in accordance with the NYSDOT Standard Specifications.

Article 5 PAYMENT PROCEDURES

CONTRACTOR shall submit Application for Payment in accordance with the NYSDOT Standard Specifications and will be processed by ENGINEER.

5.1 *Progress Payments*; OWNER shall make progress payments on account of the Contract Price on the basis of CONTRACTOR's Applications for Payment as recommended by ENGINEER, each month during construction. Such payments will be measured by the values set forth in the CONTRACTOR's Bid Schedule.

5.2 *Final Payment*. Upon final completion and acceptance of the Work in accordance with the NYSDOT Standard Specifications, OWNER shall pay the remainder of the Contract Price as recommended by ENGINEER as provided in the NYSDOT Standard Specifications.

~~**Article 6 INTEREST.**~~

~~All moneys not paid when due as provided in Article 14 of the General Conditions shall bear interest at the maximum rate allowed by law at the place of the Project.~~

Article 7 CONTRACTOR'S REPRESENTATIONS.

In order to induce OWNER to enter into this Agreement, CONTRACTOR makes the following representations:

7.1 CONTRACTOR has examined and carefully studied the Contract Documents (including the Addenda listed in paragraph 8) and the other related data identified in the Bidding Documents including "technical data".

7.2 CONTRACTOR has visited the site and become familiar with and is satisfied as to the general, local, and site conditions that may affect cost, progress, performance or furnishing of the Work.

7.3 CONTRACTOR is familiar with and is satisfied as to all federal, state, and local Laws and Regulations that may affect cost, progress, performance and furnishing of the Work.

- 7.4 CONTRACTOR agrees that before making its proposal, it carefully examined the contract documents, together with the site of the proposed work, as well as its surrounding territory, and is informed regarding all of the conditions affecting the work to be done and labor and materials to be furnished for the completion of this contract, including the existence of poles, wires, pipes, and other facilities and structures of municipal and other public services corporations on, over or under the site, except latent conditions that meet the requirements of Standard Specification Section 104-03 Differing site conditions, and that its information was secured by person and other investigation and research.
- 7.5 CONTRACTOR is aware of the general nature of work to be performed by OWNER and others at the site that relates to the Work as indicated in the Contract Documents.
- 7.6 CONTRACTOR has correlated the information known to CONTRACTOR, information and observation obtained from visits to the site, reports, and drawings identified in the Contract Documents and all additional examinations, investigations, explorations, tests, studies, and data with the Contract Documents.
- 7.7 CONTRACTOR has given ENGINEER written notice of all conflicts, errors, ambiguities or discrepancies that CONTRACTOR has discovered in the Contract Documents and the written resolution thereof by ENGINEER is acceptable to CONTRACTOR, and the Contract Documents are generally sufficient to indicate and convey understanding of all terms and conditions for performance and furnishing of the Work.

Article 8 CONTRACT DOCUMENTS

The Contract Documents which comprise the entire Agreement between OWNER and CONTRACTOR concerning the Work consist of the following:

- 8.1 This Agreement (pages 1 to 5, inclusive).
- 8.2 Performance, Payment, and other Bonds (Labeled , ,)
- 8.3 NYS Standard Specifications adopted on January 01, 2019. (incorporation by reference)
- 8.4 NYS Standard Sheets adopted on January 01, 2019. (incorporation by reference)
- 8.5 Standard Clauses for New York State Contracts
- 8.6 Specifications and guidelines bearing the general title Project Manual for Campsite Road over the Hudson River - Bridge Replacement and all amendments (incorporation by reference)
- 8.7 Drawings consisting of a cover sheet and sheets numbered 1 through 38, inclusive with each sheet bearing the following general title (incorporation by reference):
- Campsite Road over the Hudson River
Bridge Replacement
Town of Newcomb, Essex County, New York
- 8.8 Addenda numbers to , inclusive. (attached to this agreement)
- 8.9 CONTRACTOR's Bid (pages to , inclusive) marked exhibit A.
- 8.10 Documentation submitted by CONTRACTOR prior to Notice of Award (pages C- to C- , inclusive).

8.11 The following which may be delivered or issued after the Effective Date of the Agreement and are not attached hereto: All Written Amendments and other documents amending, modifying or supplementing the Contract Documents.

The documents listed in paragraph 8.2 et seq. above are attached to this Agreement (except as expressly noted otherwise above).

There are not Contract Documents other than those listed above in this Article 8. The Contract Documents may only be amended, modified or supplemented as provided in the NYSDOT Standard Specifications.

Article 9 MISCELLANEOUS

9.1 Terms used in this Agreement which are defined in the NYS Standard Specifications will have the meanings indicated in the NYS Standard Specifications.

9.2 No assignment by a party hereto of any rights under or interests in the Contract Documents will be binding on another party hereto without the written consent of the party sought to be bound; and, specifically but without limitation, moneys that may become due and moneys that are due may not be assigned without such consent (except to the extent that the effect of this restriction may be limited by law), and unless specifically stated to the contrary in any written consent to an assignment, no assignment will release or discharge the assignor from any duty or responsibility under the Contract Documents.

9.3 OWNER and CONTRACTOR each binds itself, its partners, successors, assigns and legal representatives to the other party hereto, its partners, successors, assign and legal representatives in respect to all covenants, agreements, and obligations contained in the Contract Documents.

9.4 Any provisions or part of the Contract Documents held to be void or unenforceable under any Law or Regulation shall be deemed stricken, and all remaining provisions shall continue to be valid and binding upon OWNER and CONTRACTOR, who agree that the Contract Documents shall be reformed to replace such stricken provision or part thereof with a valid and enforceable provision that comes as close as possible to expressing the intention of the stricken provision.

9.5 New York law shall apply to resolve any and all controversies related to or arising out of this Agreement. Venue of any such legal action shall be Supreme Court, Essex County, New York.

9.6 The CONTRACTOR shall defend, indemnify and hold harmless the OWNER to the fullest extent allowed by law, and notwithstanding any insurance requirements, from and against any and all liability, losses, claims, actions, demands, damages, expenses, suits, judgments, orders, causes of action and claims, including but not limited to attorney's fees and all other costs of defense, by reason of any liability whatsoever imposed by law or otherwise upon the OWNER for damages to person, property or of any other kind in nature, including but not limited to those for bodily injury, property damage, death arising out of or in connection with its officers, employees, agents, contractors, sub-contractors, guests or invitees negligence or its/their performance or failure to perform this Agreement.

IN WITNESS WHEREOF, OWNER, and CONTRACTOR have signed this Agreement in triplicate. One counterpart each has been delivered to OWNER, CONTRACTOR, and ENGINEER. All portions of the Contract Documents have been signed, initialed or identified by OWNER, and CONTRACTOR, or identified by ENGINEER on their behalf.

This Agreement will be effective on _____, 2019 (which is the Effective Date of the Agreement).

OWNER _____

CONTRACTOR _____

By: _____

By: _____

(CORPORATE SEAL)

(CORPORATE SEAL)

Attest _____

Attest _____

Address for giving notices

Address for giving notices

License No. _____

Agent for services of process: _____

(If OWNER is a public body, attach evidence of authority to sign and resolution or other documents authorizing execution of Agreement.)

(If CONTRACTOR is a corporation, attach evidence of authority to sign.)

(This Page Intentionally Left Blank)

CERTIFICATE OF ATTORNEY – OWNER

I, the undersigned

the duly authorized and acting legal representative of the

do hereby certify that I have examined the foregoing contract and the Surety Bond attached thereto and the manner of execution thereof, and that I am of the opinion that each of the aforesaid agreements has been executed by the proper representatives, and that said representatives have respectively the full power and authority to execute said agreements on behalf of the respective parties named therein, and that the foregoing agreements constitute valid and legally binding obligations upon the parties executing the same in accordance with the terms, conditions and provisions thereof.

Signed: _____

Title: _____

Date: _____

(This Page Intentionally Left Blank)

AFFIDAVIT - WORKER'S COMPENSATION

State of _____

SS: _____

County of _____

of _____

being duly sworn, deposes and says that he now carries that he has applied for a Worker's Compensation Policy to cover the operations, as set forth in the preceding contract, and to comply with the provisions thereof.

Signed: _____

Subscribed and sworn to before me

this _____ day of _____, 2019

Notary Public

(This Page Intentionally Left Blank)

CONSTRUCTION PERFORMANCE BOND

Any singular reference to Contractor, Surety, Owner, or other party shall be considered plural where applicable.

CONTRACTOR (Name and Address):

SURETY (Name and Principal Place of Business):

OWNER (Name and Address):

CONSTRUCTION CONTRACT

Date:

Amount:

Description (Name and Location):

BOND

Date (Not earlier than Construction Contract Date):

Amount:

Modifications to this Bond Form:

	CONTRACTOR AS PRINCIPAL		SURETY
Company:	(Corp. Seal)	Company:	(Corp. Seal)
Signature: _____		Signature: _____	
Name and Title:		Name and Title:	

	CONTRACTOR AS PRINCIPAL		SURETY
Company:	(Corp. Seal)	Company:	(Corp. Seal)
Signature: _____		Signature: _____	
Name and Title:		Name and Title:	

EJCDC No. 1910-28A (1984 Edition)
 Prepared through the joint efforts of The Surety Association of America, Engineers' Joint Contract Documents Committee, The Associated General Contractors of America, and the American Institute of Architects.

1. The Contractor and the Surety, jointly and severally, bind themselves, their heirs, executors, administrators, successors, and assigns to the Owner for the performance of the Construction Contract, which is incorporated herein by reference.
2. If the Contractor performs the Construction Contract, the Surety and the Contractor shall have no obligation under this Bond, except to participate in conferences as provided in Subparagraph 3.1.
3. If there is no Owner Default, the Surety's obligation under this Bond shall arise after:
 - 3.1 The Owner has notified the Contractor and the Surety at its address described in Paragraph 10 below, that the Owner is considering declaring a Contractor Default and has requested and attempted to arrange a conference with the Contractor and the Surety to be held not later than fifteen days after receipt of such notice to discuss methods of performing the Construction Contract. If the Owner and the Contractor and the Surety agree, the Contractor shall be allowed a reasonable time to perform the Construction Contract, but such an agreement shall not waive the Owner's right, if any subsequently to declare a Contractor Default; and
 - 3.2 The Owner has declared a Contractor Default and formally terminated the Contractor's right to complete the contract. Such Contractor Default shall not be declared earlier than twenty days after the Contractor and the Surety have received notice as provided in Subparagraph 3.1; and
 - 3.3 The Owner has agreed to pay the Balance of the Contract Price to the Surety in accordance with the terms of the Construction Contract or to a contractor selected to perform the Construction Contract in accordance with the terms of the contract with the Owner.
4. When the Owner has satisfied the conditions of Paragraph 3, the Surety shall promptly and at the Surety's expense take one of the following actions:
 - 4.1 Arrange for the Contractor, with Consent of the Owner, to perform and complete the Construction Contract; or
 - 4.2 Undertake to perform and complete the Construction Contract itself, through its agents or through independent contractors; or
 - 4.3 Obtain bids or negotiated proposals from qualified contractors acceptable to the Owner for Contract or performance and completion of the Construction Contract, arrange for a contract to be prepared for execution by the Owner and the Contractor selected with the Owner's concurrence, to be secured with performance and payment bonds executed by qualified surety equivalent to the bonds issued on the Construction Contract, and pay to the Owner the amount of damages as described in Paragraph 6 in excess of the Balance of the Contract Price incurred by the Owner resulting from the Contractor's default; or
 - 4.4 Waive its right to perform and complete, arrange for completion, or obtain a new contractor and with reasonable promptness under the circumstances.
 1. After investigation, determine the amount for which it may be liable to the Owner and, as soon as practicable after the amount is determined, tender payment therefore to the Owner; or
 2. Deny liability in whole or in part and notify the Owner citing reasons therefore.
5. If the Surety does not proceed as provided in Paragraph 4 with reasonable promptness, the Surety shall be deemed to be in default on this bond fifteen days after receipt of an additional written notice from the Owner to the Surety demanding that the Surety perform its obligations under this Bond, and the Owner shall be entitled to enforce any remedy available to the Owner. If the Surety proceeds as provided in Subparagraph 4.4, and the Owner refuses the payment tendered or the Surety has denied liability, in whole or in part, without further notice the Owner shall be entitled to enforce any remedy available to the Owner.
6. After the Owner has terminated the Contractor's right to complete the Construction Contract, and if the Surety elects to act under Subparagraph 4.1, 4.2, or 4.3 above, then the responsibilities of the Surety to the Owner shall not be greater than those of the Contractor under the Construction Contract, and the responsibilities of the Owner to the Surety shall not be greater than those of the Owner under the Construction Contract. To the limit of the amount of this Bond, but subject to commitment by the Owner of the Balance of the Contract Price to mitigation of costs and damages on the Construction Contract, the Surety is obligated without duplication for:
 - 6.1 The responsibilities of the Contractor for correction of defective work and completion of the Construction Contract;
 - 6.2 Additional legal design professional and delay costs resulting from the Contractor's Default, and resulting from the actions or failure to act of the Surety under Paragraph 4; and
 - 6.3 Liquidated damages, or if no liquidated damages are specified in the Construction Contract, actual damages caused by delayed performance or non-performance of the Contractor.
7. The Surety shall not be liable to the Owner or others for obligations of the Contractor that are unrelated to the Construction Contract, and the Balance of the Contract Price shall not be reduced or set off on account of any such unrelated obligations. No right of action shall accrue on this Bond to any person or entity other than the Owner or its heirs, executors, administrators, or successors.
8. The Surety hereby waives notice of any change, include changes of time to the Construction Contract or to related subcontracts, purchase orders and other obligations.
9. Any proceeding, legal, or equitable, under this Bond may be instituted in any court of competent jurisdiction in the location in which the work or part of the work is located and shall be instituted within two years after Contractor Default or within two years after the Contractor ceased working or within two years after the Surety refuses or fails to perform its obligations under this Bond, whichever occurs first. If the provisions of this Paragraph are void or prohibited by the law, the minimum period of limitation available to sureties as a defense in the jurisdiction of the suit shall be applicable.
10. Notice to the Surety, the Owner or the Contractor shall be mailed or delivered to the address shown on the signature page.
11. When this bond has been furnished to comply with a statutory or other legal requirements in the location where the construction was to be performed, any provision in this Bond conflicting with said statutory or legal requirements shall be deemed deleted here from and provisions conforming to such statutory or other legal requirements shall be deemed incorporated herein. The intent is that this Bond shall be construed as a statutory bond and not as a common law bond.
12. Definitions.
 - 12.1 Balance of the Contract Price: The total amount payable by the Owner to the Contractor under the Construction Contract after all proper adjustments have been made, including allowance to the Contractor of any amount received or to be received by the Owner in settlement of insurance or other claims for damages to which the Contractor is entitled, reduce by all valid and proper payments made to or on behalf of the Contractor under the Construction Contract.
 - 12.2 Construction Contract: The agreement between the Owner and the Contractor identified on the signature page, including all Contract Documents and changes thereto.
 - 12.3 Contractor Default: Failure of the Contractor, which has neither been remedied nor waived, to perform or otherwise to comply with the terms of the Construction Contract.
 - 12.4 Owner Default: Failure of the Owner, which has neither been remedied nor waived, to pay the Contractor as required by the Construction Contract or to perform and complete or comply with other terms thereof.

(FOR INFORMATION ONLY - Name, Address and Telephone) AGENT or BROKER:

CONSTRUCTION PAYMENT BOND

Any singular reference to Contractor, Surety, Owner, or other party shall be considered plural where applicable.

CONTRACTOR (Name and Address):

SURETY (Name and Principal Place of Business):

OWNER (Name and Address):

CONSTRUCTION CONTRACT

Date:

Amount:

Description (Name and Location):

BOND

Date (Not earlier than Construction Contract Date):

Amount:

Modifications to this Bond Form:

Company:	CONTRACTOR AS PRINCIPAL (Corp. Seal)	Company:	SURETY (Corp. Seal)
Signature: _____		Signature: _____	
Name and Title:		Name and Title:	

Company:	CONTRACTOR AS PRINCIPAL (Corp. Seal)	Company:	SURETY (Corp. Seal)
Signature: _____		Signature: _____	
Name and Title:		Name and Title:	

EJCDC No. 1910-28A (1984 Edition)
Prepared through the joint efforts of The Surety Association of America, Engineers' Joint Contract Documents Committee, The Associated General Contractors of America, and the American Institute of Architects.

1. The Contractor and the Surety, jointly and severally, bind themselves, their heirs, executors, administrators, successors, and assigns to the Owner to pay for labor, materials, and equipment furnished for use in the performance of the Construction Contract, which is incorporated herein by reference.

2. With respect to the Owner, this obligation shall be null and void if the Contractor:

- 2.1 Promptly makes payment, directly or indirectly, for all sums Due Claimants, and
- 2.2 Defends, indemnifies and hold harmless the Owner from all claims, demands, liens or suits by any person or entity who furnished labor, materials, or equipment for use in the performance of the Construction Contract, provided the Owner has promptly notified the Contractor and the Surety (at the address described in Paragraph 12) of any claims, demands, liens or suits and tendered defense of such claims, demands liens or suits to the Contractor and the Surety, and provided there is not Owner Default.

3. With respect to Claimants, this obligation shall be null and void if the Contractor promptly makes payment, directly or indirectly, for all sums due.

4. The Surety shall have no obligation to Claimants under this Bond until:

- 4.1 Claimants who are employed by or have a direct contract with the Contractor have given notice to the Surety (at the address described in Paragraph 12) and sent a copy, or notice thereof, to the Owner, stating that a claim is being made under this Bond and, with substantial accuracy, the amount of the claim.
- 4.2 Claimants who do not have a direct contract with the Contractor:
 - 1. Have furnished written notice to the Contractor and sent a copy, or notice thereof, to the Owner, within 90 days after having last performed labor or last furnished materials or equipment included in the claim stating, with substantial accuracy, the amount of the claim and the name of the party to whom the materials were furnished or supplied or for whom the labor was done or performed; and
 - 2. Have either received a rejection in whole or in part from the Contractor, or not received within 30 days of furnishing the above notice any communication from the Contractor by which the Contractor has indicated the claim will be paid directly or indirectly; and
 - 3. Not having been paid within the above 30 days, have sent a written notice to the Surety (at the address described in Paragraph 12) and sent a copy, or notice thereof, to the Owner stating that a claim is being made under this Bond and enclosing a copy of the previous written notice furnished to the Contractor.

5. If a notice required by Paragraph 4 is given to the Contractor to the Surety, that is sufficient compliance.

6. When the Claimant has satisfied the conditions of Paragraph 4, the Surety shall promptly and at the Surety's expense take the following actions:

- 6.1 Send an answer to the Claimant, with a copy to the Owner, within 45 days after receipt of the claim, stating the amounts that are undisputed and the basis for challenging any amounts that are disputed.
- 6.2 Pay or arrange for payment of any undisputed amounts.

7. The Surety's total obligation shall not exceed the amount of this Bond, and the amount of this Bond shall be credited for any payments made in good faith by the Surety.

8. Amount owed by the Owner to the Contractor under the Construction Contract shall be used for the performance of the Construction Contract and to satisfy claims, if any, under any Construction Performance Bond. By the Contractor furnishing and the Owner accepting this Bond, they agree that all funds earned by the Contractor in the performance of the Construction

Contract area dedicated to satisfy obligations of the Contractor and the Surety under this Bond, subject to the Owner's priority to use the funds for the completion of the work.

9. The Surety shall not be liable to the Owner, Claimants, or others for obligations of the Contractor that are unrelated to the Construction Contract. The Owner shall not be liable for payment of any costs or expenses of any claimant under this Bond, and shall have under this Bond no obligations to make payments to, give notices on behalf of, or otherwise have obligations to make obligations to Claimants under this Bond.

10. The Surety hereby waives notice of any change, including changes of time, to the Construction Contract or to related subcontracts, purchase orders and other obligations.

11. No suit or action shall be commenced by a Claimant under this Bond other than in a court of competent jurisdiction in the location in which the work or part of the work is located or after the expiration of one year from the date (1) on which the Claimant gave the notice required by Subparagraph 4.1 or Clause 4.2 (iii), or (2) on which the last labor or service was performed by anyone or the last materials or equipment were furnished by anyone under the Construction Contract, whichever of (1) or (2) first occurs. If the provisions of this Paragraph are void or prohibited by law, the minimum period of limitation available to sureties as a defense in the jurisdiction of the suit shall be applicable.

12. Notice to the Surety, the Owner or the Contractor shall be mailed or delivered to the address shown on the signature page. Actual receipt of notice by Surety, the Owner, or the Contractor, however accomplished, shall be sufficient compliance as of the date received at the address shown on the signature page.

13. When this bond has been furnished to comply with a statutory or other legal requirements in the location where the construction was to be performed, any provision in this Bond conflicting with said statutory or legal requirements shall be deemed deleted here from and provisions conforming to such statutory or other legal requirements shall be deemed incorporated herein. The intent is that this Bond shall be construed as a statutory bond and not as a common law bond.

14. Upon request by any person or entity appearing to be a potential beneficiary of this Bond, the Contractor shall promptly furnish a copy of this Bond or shall permit a copy to be made.

15. Definitions.

- 15.1 Claimant: An individual or entity have a direct contract with the Contractor or with a subcontractor of the Contractor to furnish labor, materials, or equipment for use in the performance of the Contract. The intent of this Bond shall be to include without limitation in the terms "labor, materials, or equipment" that part of water, gas, power, light, heat, oil, gasoline, telephone service or rental equipment used in; the Construction, architectural and engineering services required for performance of the work of the Contractor and the Contractor's subcontractors, and all other items for which a mechanic's lien may be asserted in the jurisdiction where the labor, materials, or equipment were furnished.
- 15.2 Construction Contract: The agreement between the Owner and the Contractor identified on the signature page, including all Contract Documents and changes thereto.
- 15.3 Owner Default: Failure of the Owner, which as neither been remedied nor waived, to pay the Contractor as required by the Construction Contract to perform and complete or comply with other terms thereof.

(FOR INFORMATION ONLY - Name, Address and Telephone)
AGENT or BROKER:

OWNER'S REPRESENTATIVE Architect, Engineer or other party):

CERTIFICATE OF INSURANCE

(Attach Insurance Certificates Here)

(This page intentionally left blank)

NEW YORK STATE UNIFORM CONTRACTING QUESTIONNAIRE

In accordance with Section 103-01 of the Standard Specifications, the New York State Department of Transportation requires that all low bidders and proposed subcontractors present evidence of ownership, experience, ability, and financial standing. All low bidders and proposed subcontractors must have a fully completed a New York State Uniform Contracting Questionnaire on file with the Department to be considered for the award of a contract or the approval of a subcontract. If a current questionnaire is not on file at the time a low bid is submitted, the Department may exercise its option under Section 38 of the Highway Law and hold the low bidder's bid deposit until such time as a completed questionnaire is received. New York State Uniform Contracting Questionnaires can be obtained from the Office of Contract Management Pre-Award Unit by calling (518) 457-1564 or from the following website:

<https://www.dot.ny.gov/bids-and-lettings/construction-contractors/general-info>

Any low bidder who does not have a completed New York State Contracting Questionnaire on file within ten days of receipt of the contract for execution may be subject to forfeiture of the amount of bid deposit pursuant to Section 103-02 of the Standard Specifications.

ADDENDUM A

This is a federally-aided contract subject to the approval of the New York State Department of Transportation (NYSDOT).

The low bidder will be required to complete a New York State Uniform Contracting Questionnaire, which must be approved by NYSDOT prior to an award being made.

Whenever local requirements differ from Federal requirements, the Federal requirements will prevail.

ADDENDUM B

Where the NYSDOT is mentioned in any capacity (including, but not limited to, Department, State, Commissioner of Transportation, DOT, DCES or Director(s) of its subdivisions) as an approving authority with regard to materials, fabrication, inspections or other approvals, the approving authority shall be changed to the OWNER. This change shall be made in all of the documents relating to this contract.

CERTIFICATE OF INSURANCE

(Attach Insurance Certificates Here)

NEW YORK STATE UNIFORM CONTRACTING QUESTIONNAIRE

In accordance with Section 103-01 of the Standard Specifications, the New York State Department of Transportation requires that all low bidders and proposed subcontractors present evidence of ownership, experience, ability, and financial standing. All low bidders and proposed subcontractors must have a fully completed a New York State Uniform Contracting Questionnaire on file with the Department to be considered for the award of a contract or the approval of a subcontract. If a current questionnaire is not on file at the time a low bid is submitted, the Department may exercise its option under Section 38 of the Highway Law and hold the low bidder's bid deposit until such time as a completed questionnaire is received. New York State Uniform Contracting Questionnaires can be obtained from the Office of Contract Management Pre-Award Unit by calling (518) 457-1564 or from the following website:

<https://www.dot.ny.gov/bids-and-lettings/construction-contractors/general-info>

Any low bidder who does not have a completed New York State Contracting Questionnaire on file within ten days of receipt of the contract for execution may be subject to forfeiture of the amount of bid deposit pursuant to Section 103-02 of the Standard Specifications.

ADDENDUM A

This is a federally-aided contract subject to the approval of the New York State Department of Transportation (NYSDOT).

The low bidder will be required to complete a New York State Uniform Contracting Questionnaire, which must be approved by NYSDOT prior to an award being made.

Whenever local requirements differ from Federal requirements, the Federal requirements will prevail.

ADDENDUM B

Where the NYSDOT is mentioned in any capacity (including, but not limited to, Department, State, Commissioner of Transportation, DOT, DCES or Director(s) of its subdivisions) as an approving authority with regard to materials, fabrication, inspections or other approvals, the approving authority shall be changed to the OWNER. This change shall be made in all of the documents relating to this contract.

(This page intentionally left blank)

APPENDIX A

STANDARD CLAUSES FOR NEW YORK STATE CONTRACTS

TABLE OF CONTENTS

	Page
1. Executory Clause	3
2. Non-Assignment Clause	3
3. Comptroller's Approval	3
4. Workers' Compensation Benefits	3
5. Non-Discrimination Requirements	3
6. Wage and Hours Provisions	3
7. Non-Collusive Bidding Certification	4
8. International Boycott Prohibition	4
9. Set-Off Rights	4
10. Records	4
11. Identifying Information and Privacy Notification	4
12. Equal Employment Opportunities For Minorities and Women	4-5
13. Conflicting Terms	5
14. Governing Law	5
15. Late Payment	5
16. No Arbitration	5
17. Service of Process	5
18. Prohibition on Purchase of Tropical Hardwoods	5-6
19. MacBride Fair Employment Principles	6
20. Omnibus Procurement Act of 1992	6
21. Reciprocity and Sanctions Provisions	6
22. Compliance with New York State Information Security Breach and Notification Act	6
23. Compliance with Consultant Disclosure Law	6
24. Procurement Lobbying	7
25. Certification of Registration to Collect Sales and Compensating Use Tax by Certain State Contractors, Affiliates and Subcontractors	7

STANDARD CLAUSES FOR NYS CONTRACTS

The parties to the attached contract, license, lease, amendment or other agreement of any kind (hereinafter, "the contract" or "this contract") agree to be bound by the following clauses which are hereby made a part of the contract (the word "Contractor" herein refers to any party other than the State, whether a contractor, licenser, licensee, lessor, lessee or any other party):

1. EXECUTORY CLAUSE. In accordance with Section 41 of the State Finance Law, the State shall have no liability under this contract to the Contractor or to anyone else beyond funds appropriated and available for this contract.

2. NON-ASSIGNMENT CLAUSE. In accordance with Section 138 of the State Finance Law, this contract may not be assigned by the Contractor or its right, title or interest therein assigned, transferred, conveyed, sublet or otherwise disposed of without the State's previous written consent, and attempts to do so are null and void. Notwithstanding the foregoing, such prior written consent of an assignment of a contract let pursuant to Article XI of the State Finance Law may be waived at the discretion of the contracting agency and with the concurrence of the State Comptroller where the original contract was subject to the State Comptroller's approval, where the assignment is due to a reorganization, merger or consolidation of the Contractor's business entity or enterprise. The State retains its right to approve an assignment and to require that any Contractor demonstrate its responsibility to do business with the State. The Contractor may, however, assign its right to receive payments without the State's prior written consent unless this contract concerns Certificates of Participation pursuant to Article 5-A of the State Finance Law.

3. COMPTROLLER'S APPROVAL. In accordance with Section 112 of the State Finance Law (or, if this contract is with the State University or City University of New York, Section 355 or Section 6218 of the Education Law), if this contract exceeds \$50,000 (or the minimum thresholds agreed to by the Office of the State Comptroller for certain S.U.N.Y. and C.U.N.Y. contracts), or if this is an amendment for any amount to a contract which, as so amended, exceeds said statutory amount, or if, by this contract, the State agrees to give something other than money when the value or reasonably estimated value of such consideration exceeds \$10,000, it shall not be valid, effective or binding upon the State until it has been approved by the State Comptroller and filed in his office. Comptroller's approval of contracts let by the Office of General Services is required when such contracts exceed \$85,000 (State Finance Law Section 163.6.a).

4. WORKERS' COMPENSATION BENEFITS. In accordance with Section 142 of the State Finance Law, this contract shall be void and of no force and effect unless the Contractor shall provide and maintain coverage during the life of this contract for the benefit of such employees as are

required to be covered by the provisions of the Workers' Compensation Law.

5. NON-DISCRIMINATION REQUIREMENTS. To the extent required by Article 15 of the Executive Law (also known as the Human Rights Law) and all other State and Federal statutory and constitutional non-discrimination provisions, the Contractor will not discriminate against any employee or applicant for employment because of race, creed, color, sex, national origin, sexual orientation, age, disability, genetic predisposition or carrier status, or marital status. Furthermore, in accordance with Section 220-e of the Labor Law, if this is a contract for the construction, alteration or repair of any public building or public work or for the manufacture, sale or distribution of materials, equipment or supplies, and to the extent that this contract shall be performed within the State of New York, Contractor agrees that neither it nor its subcontractors shall, by reason of race, creed, color, disability, sex, or national origin: (a) discriminate in hiring against any New York State citizen who is qualified and available to perform the work; or (b) discriminate against or intimidate any employee hired for the performance of work under this contract. If this is a building service contract as defined in Section 230 of the Labor Law, then, in accordance with Section 239 thereof, Contractor agrees that neither it nor its subcontractors shall by reason of race, creed, color, national origin, age, sex or disability: (a) discriminate in hiring against any New York State citizen who is qualified and available to perform the work; or (b) discriminate against or intimidate any employee hired for the performance of work under this contract. Contractor is subject to fines of \$50.00 per person per day for any violation of Section 220-e or Section 239 as well as possible termination of this contract and forfeiture of all moneys due hereunder for a second or subsequent violation.

6. WAGE AND HOURS PROVISIONS. If this is a public work contract covered by Article 8 of the Labor Law or a building service contract covered by Article 9 thereof, neither Contractor's employees nor the employees of its subcontractors may be required or permitted to work more than the number of hours or days stated in said statutes, except as otherwise provided in the Labor Law and as set forth in prevailing wage and supplement schedules issued by the State Labor Department. Furthermore, Contractor and its subcontractors must pay at least the prevailing wage rate and pay or provide the prevailing supplements, including the premium rates for overtime pay, as determined by the State Labor Department in accordance with the Labor Law. Additionally, effective April 28, 2008, if this is a public work contract covered by Article 8 of the Labor Law, the Contractor understands and agrees that the filing of payrolls in a manner consistent with Subdivision 3-a of Section 220 of the Labor Law shall be a condition precedent to payment by the State of any State approved sums due and owing for work done upon the project.

7. NON-COLLUSIVE BIDDING CERTIFICATION. In accordance with Section 139-d of the State Finance Law, if this contract was awarded based upon the submission of bids, Contractor affirms, under penalty of perjury, that its bid was arrived at independently and without collusion aimed at restricting competition. Contractor further affirms that, at the time Contractor submitted its bid, an authorized and responsible person executed and delivered to the State a non-collusive bidding certification on Contractor's behalf.

8. INTERNATIONAL BOYCOTT PROHIBITION. In accordance with Section 220-f of the Labor Law and Section 139-h of the State Finance Law, if this contract exceeds \$5,000, the Contractor agrees, as a material condition of the contract, that neither the Contractor nor any substantially owned or affiliated person, firm, partnership or corporation has participated, is participating, or shall participate in an international boycott in violation of the federal Export Administration Act of 1979 (50 USC App. Sections 2401 et seq.) or regulations thereunder. If such Contractor, or any of the aforesaid affiliates of Contractor, is convicted or is otherwise found to have violated said laws or regulations upon the final determination of the United States Commerce Department or any other appropriate agency of the United States subsequent to the contract's execution, such contract, amendment or modification thereto shall be rendered forfeit and void. The Contractor shall so notify the State Comptroller within five (5) business days of such conviction, determination or disposition of appeal (2NYCRR 105.4).

9. SET-OFF RIGHTS. The State shall have all of its common law, equitable and statutory rights of set-off. These rights shall include, but not be limited to, the State's option to withhold for the purposes of set-off any moneys due to the Contractor under this contract up to any amounts due and owing to the State with regard to this contract, any other contract with any State department or agency, including any contract for a term commencing prior to the term of this contract, plus any amounts due and owing to the State for any other reason including, without limitation, tax delinquencies, fee delinquencies or monetary penalties relative thereto. The State shall exercise its set-off rights in accordance with normal State practices including, in cases of set-off pursuant to an audit, the finalization of such audit by the State agency, its representatives, or the State Comptroller.

10. RECORDS. The Contractor shall establish and maintain complete and accurate books, records, documents, accounts and other evidence directly pertinent to performance under this contract (hereinafter, collectively, "the Records"). The Records must be kept for the balance of the calendar year in which they were made and for six (6) additional years thereafter. The State Comptroller, the Attorney General and any other person or entity authorized to conduct an examination, as well as the agency or agencies involved in this contract, shall have access to the Records during normal business hours at an office of the Contractor within the State of New York or, if no such office is available, at a mutually

agreeable and reasonable venue within the State, for the term specified above for the purposes of inspection, auditing and copying. The State shall take reasonable steps to protect from public disclosure any of the Records which are exempt from disclosure under Section 87 of the Public Officers Law (the "Statute") provided that: (i) the Contractor shall timely inform an appropriate State official, in writing, that said records should not be disclosed; and (ii) said records shall be sufficiently identified; and (iii) designation of said records as exempt under the Statute is reasonable. Nothing contained herein shall diminish, or in any way adversely affect, the State's right to discovery in any pending or future litigation.

11. IDENTIFYING INFORMATION AND PRIVACY NOTIFICATION. (a) Identification Number(s). Every invoice or New York State Claim for Payment submitted to a New York State agency by a payee, for payment for the sale of goods or services or for transactions (e.g., leases, easements, licenses, etc.) related to real or personal property must include the payee's identification number. The number is any or all of the following: (i) the payee's Federal employer identification number, (ii) the payee's Federal social security number, and/or (iii) the payee's Vendor Identification Number assigned by the Statewide Financial System. Failure to include such number or numbers may delay payment. Where the payee does not have such number or numbers, the payee, on its invoice or Claim for Payment, must give the reason or reasons why the payee does not have such number or numbers.

(b) Privacy Notification. (1) The authority to request the above personal information from a seller of goods or services or a lessor of real or personal property, and the authority to maintain such information, is found in Section 5 of the State Tax Law. Disclosure of this information by the seller or lessor to the State is mandatory. The principal purpose for which the information is collected is to enable the State to identify individuals, businesses and others who have been delinquent in filing tax returns or may have understated their tax liabilities and to generally identify persons affected by the taxes administered by the Commissioner of Taxation and Finance. The information will be used for tax administration purposes and for any other purpose authorized by law. (2) The personal information is requested by the purchasing unit of the agency contracting to purchase the goods or services or lease the real or personal property covered by this contract or lease. The information is maintained in the Statewide Financial System by the Vendor Management Unit within the Bureau of State Expenditures, Office of the State Comptroller, 110 State Street, Albany, New York 12236.

r

12. EQUAL EMPLOYMENT OPPORTUNITIES FOR MINORITIES AND WOMEN. In accordance with Section 312 of the Executive Law and 5 NYCRR 143, if this contract is: (i) a written agreement or purchase order instrument, providing for a total expenditure in excess of \$25,000.00, whereby a contracting agency is committed to expend or does expend funds in return for labor, services, supplies, equipment, materials or any combination of the foregoing, to

be performed for, or rendered or furnished to the contracting agency; or (ii) a written agreement in excess of \$100,000.00 whereby a contracting agency is committed to expend or does expend funds for the acquisition, construction, demolition, replacement, major repair or renovation of real property and improvements thereon; or (iii) a written agreement in excess of \$100,000.00 whereby the owner of a State assisted housing project is committed to expend or does expend funds for the acquisition, construction, demolition, replacement, major repair or renovation of real property and improvements thereon for such project, then the following shall apply and by signing this agreement the Contractor certifies and affirms that it is Contractor's equal employment opportunity policy that:

(a) The Contractor will not discriminate against employees or applicants for employment because of race, creed, color, national origin, sex, age, disability or marital status, shall make and document its conscientious and active efforts to employ and utilize minority group members and women in its work force on State contracts and will undertake or continue existing programs of affirmative action to ensure that minority group members and women are afforded equal employment opportunities without discrimination. Affirmative action shall mean recruitment, employment, job assignment, promotion, upgradings, demotion, transfer, layoff, or termination and rates of pay or other forms of compensation;

(b) at the request of the contracting agency, the Contractor shall request each employment agency, labor union, or authorized representative of workers with which it has a collective bargaining or other agreement or understanding, to furnish a written statement that such employment agency, labor union or representative will not discriminate on the basis of race, creed, color, national origin, sex, age, disability or marital status and that such union or representative will affirmatively cooperate in the implementation of the Contractor's obligations herein; and

(c) the Contractor shall state, in all solicitations or advertisements for employees, that, in the performance of the State contract, all qualified applicants will be afforded equal employment opportunities without discrimination because of race, creed, color, national origin, sex, age, disability or marital status.

Contractor will include the provisions of "a", "b", and "c" above, in every subcontract over \$25,000.00 for the construction, demolition, replacement, major repair, renovation, planning or design of real property and improvements thereon (the "Work") except where the Work is for the beneficial use of the Contractor. Section 312 does not apply to: (i) work, goods or services unrelated to this contract; or (ii) employment outside New York State. The State shall consider compliance by a contractor or subcontractor with the requirements of any federal law concerning equal employment opportunity which effectuates the purpose of this section. The contracting agency shall determine whether the imposition of the requirements of the provisions hereof duplicate or conflict

with any such federal law and if such duplication or conflict exists, the contracting agency shall waive the applicability of Section 312 to the extent of such duplication or conflict. Contractor will comply with all duly promulgated and lawful rules and regulations of the Department of Economic Development's Division of Minority and Women's Business Development pertaining hereto.

13. CONFLICTING TERMS. In the event of a conflict between the terms of the contract (including any and all attachments thereto and amendments thereof) and the terms of this Appendix A, the terms of this Appendix A shall control.

14. GOVERNING LAW. This contract shall be governed by the laws of the State of New York except where the Federal supremacy clause requires otherwise.

15. LATE PAYMENT. Timeliness of payment and any interest to be paid to Contractor for late payment shall be governed by Article 11-A of the State Finance Law to the extent required by law.

16. NO ARBITRATION. Disputes involving this contract, including the breach or alleged breach thereof, may not be submitted to binding arbitration (except where statutorily authorized), but must, instead, be heard in a court of competent jurisdiction of the State of New York.

17. SERVICE OF PROCESS. In addition to the methods of service allowed by the State Civil Practice Law & Rules ("CPLR"), Contractor hereby consents to service of process upon it by registered or certified mail, return receipt requested. Service hereunder shall be complete upon Contractor's actual receipt of process or upon the State's receipt of the return thereof by the United States Postal Service as refused or undeliverable. Contractor must promptly notify the State, in writing, of each and every change of address to which service of process can be made. Service by the State to the last known address shall be sufficient. Contractor will have thirty (30) calendar days after service hereunder is complete in which to respond.

18. PROHIBITION ON PURCHASE OF TROPICAL HARDWOODS. The Contractor certifies and warrants that all wood products to be used under this contract award will be in accordance with, but not limited to, the specifications and provisions of Section 165 of the State Finance Law, (Use of Tropical Hardwoods) which prohibits purchase and use of tropical hardwoods, unless specifically exempted, by the State or any governmental agency or political subdivision or public benefit corporation. Qualification for an exemption under this law will be the responsibility of the contractor to establish to meet with the approval of the State.

In addition, when any portion of this contract involving the use of woods, whether supply or installation, is to be performed by any subcontractor, the prime Contractor will indicate and certify in the submitted bid proposal that the

subcontractor has been informed and is in compliance with specifications and provisions regarding use of tropical hardwoods as detailed in §165 State Finance Law. Any such use must meet with the approval of the State; otherwise, the bid may not be considered responsive. Under bidder certifications, proof of qualification for exemption will be the responsibility of the Contractor to meet with the approval of the State.

19. MACBRIDE FAIR EMPLOYMENT PRINCIPLES.

In accordance with the MacBride Fair Employment Principles (Chapter 807 of the Laws of 1992), the Contractor hereby stipulates that the Contractor either (a) has no business operations in Northern Ireland, or (b) shall take lawful steps in good faith to conduct any business operations in Northern Ireland in accordance with the MacBride Fair Employment Principles (as described in Section 165 of the New York State Finance Law), and shall permit independent monitoring of compliance with such principles.

20. OMNIBUS PROCUREMENT ACT OF 1992. It is the policy of New York State to maximize opportunities for the participation of New York State business enterprises, including minority and women-owned business enterprises as bidders, subcontractors and suppliers on its procurement contracts.

Information on the availability of New York State subcontractors and suppliers is available from:

NYS Department of Economic Development
Division for Small Business
30 South Pearl St -- 7th Floor
Albany, New York 12245
Telephone: 518-292-5220
Fax: 518-292-5884
<http://www.empire.state.ny.us>

A directory of certified minority and women-owned business enterprises is available from:

NYS Department of Economic Development
Division of Minority and Women's Business Development
30 South Pearl St -- 2nd Floor
Albany, New York 12245
Telephone: 518-292-5250
Fax: 518-292-5803
<http://www.empire.state.ny.us>

The Omnibus Procurement Act of 1992 requires that by signing this bid proposal or contract, as applicable, Contractors certify that whenever the total bid amount is greater than \$1 million:

(a) The Contractor has made reasonable efforts to encourage the participation of New York State Business Enterprises as suppliers and subcontractors, including certified minority and women-owned business enterprises, on this project, and has

retained the documentation of these efforts to be provided upon request to the State;

(b) The Contractor has complied with the Federal Equal Opportunity Act of 1972 (P.L. 92-261), as amended;

(c) The Contractor agrees to make reasonable efforts to provide notification to New York State residents of employment opportunities on this project through listing any such positions with the Job Service Division of the New York State Department of Labor, or providing such notification in such manner as is consistent with existing collective bargaining contracts or agreements. The Contractor agrees to document these efforts and to provide said documentation to the State upon request; and

(d) The Contractor acknowledges notice that the State may seek to obtain offset credits from foreign countries as a result of this contract and agrees to cooperate with the State in these efforts.

21. RECIPROCITY AND SANCTIONS PROVISIONS.

Bidders are hereby notified that if their principal place of business is located in a country, nation, province, state or political subdivision that penalizes New York State vendors, and if the goods or services they offer will be substantially produced or performed outside New York State, the Omnibus Procurement Act 1994 and 2000 amendments (Chapter 684 and Chapter 383, respectively) require that they be denied contracts which they would otherwise obtain. NOTE: As of May 15, 2002, the list of discriminatory jurisdictions subject to this provision includes the states of South Carolina, Alaska, West Virginia, Wyoming, Louisiana and Hawaii. Contact NYS Department of Economic Development for a current list of jurisdictions subject to this provision.

22. COMPLIANCE WITH NEW YORK STATE INFORMATION SECURITY BREACH AND NOTIFICATION ACT.

Contractor shall comply with the provisions of the New York State Information Security Breach and Notification Act (General Business Law Section 899-aa; State Technology Law Section 208).

23. COMPLIANCE WITH CONSULTANT DISCLOSURE LAW.

If this is a contract for consulting services, defined for purposes of this requirement to include analysis, evaluation, research, training, data processing, computer programming, engineering, environmental, health, and mental health services, accounting, auditing, paralegal, legal or similar services, then, in accordance with Section 163 (4-g) of the State Finance Law (as amended by Chapter 10 of the Laws of 2006), the Contractor shall timely, accurately and properly comply with the requirement to submit an annual employment report for the contract to the agency that awarded the contract, the Department of Civil Service and the State Comptroller.

24. PROCUREMENT LOBBYING. To the extent this agreement is a "procurement contract" as defined by State Finance Law Sections 139-j and 139-k, by signing this agreement the contractor certifies and affirms that all disclosures made in accordance with State Finance Law Sections 139-j and 139-k are complete, true and accurate. In the event such certification is found to be intentionally false or intentionally incomplete, the State may terminate the agreement by providing written notification to the Contractor in accordance with the terms of the agreement.

25. CERTIFICATION OF REGISTRATION TO COLLECT SALES AND COMPENSATING USE TAX BY CERTAIN STATE CONTRACTORS, AFFILIATES AND SUBCONTRACTORS.

To the extent this agreement is a contract as defined by Tax Law Section 5-a, if the contractor fails to make the certification required by Tax Law Section 5-a or if during the term of the contract, the Department of Taxation and Finance or the covered agency, as defined by Tax Law 5-a, discovers that the certification, made under penalty of perjury, is false, then such failure to file or false certification shall be a material breach of this contract and this contract may be terminated, by providing written notification to the Contractor in accordance with the terms of the agreement, if the covered agency determines that such action is in the best interest of the State.

IV. SPECIAL NOTES LISTING

SPECIAL NOTES LIST

- CONR 9K Supplemental Information For Bidders
- Controlling Exposure to Diesel Exhaust
- Coordination with Utilities
- Dust Control
- Emergency Contact Numbers
- Guide Rail Downtime Restrictions
- Insurance Supplement
- New York State Prevailing Wage Rates
- Office Technology Supplies
- Price Adjustments
- ROW Availability
- Special Specification Item Numbers
- Superpave Hot Mix Asphalt Performance Specification
- Temporary Lane Closure Restriction
- Ultra Low Sulfur Diesel Fuel
- Warm Mix Asphalt Technologies
- PG Binder and Mix Design Level
- Turf Establishment – Seed Mix As Specified

(This Page Intentionally Left Blank)

SUPPLEMENTAL INFORMATION AVAILABLE TO BIDDERS

The information checked in the "Digital" column on this form is available at the Contract Documents tab within the Construction Contracting section of the [Business Center](#) on the Department's web site. The information checked in the "Inspection Only" column on this form is available at the Regional Office having jurisdiction for this project, as identified in the advertisement for bids, for inspection and review prior to the letting date. The bidder's signature on this proposal certifies that they have made themselves aware of the availability of the information indicated below:

THERE IS NO SUPPLEMENTAL INFORMATION AVAILABLE FOR THIS CONTRACT:

INFORMATION	Digital ¹	Inspection Only
1. Greyscale PDF of Sealed Plan Set (for printing) ^{2,3}	<input checked="" type="checkbox"/>	
2. Unsealed Layered or 3D PDF Files	<input type="checkbox"/>	
3. CADD Information (Successful Bidder Only)		
a. MicroStation DGN	<input type="checkbox"/>	
b. InRoads DTM and XML format	<input type="checkbox"/>	
c. InRoads ALG and XML format	<input type="checkbox"/>	
4. Cross Sections in ADOBE PDF format	<input type="checkbox"/>	
5. Quantity Work-ups	<input type="checkbox"/>	
6. Record Plans	<input checked="" type="checkbox"/>	<input type="checkbox"/>
7. Rock Cores (available for inspection only)		<input type="checkbox"/>
8. Sign Face Layouts in ADOBE PDF format	<input type="checkbox"/>	
9. Stormwater Pollution Prevention Plan (SWPPP)	<input type="checkbox"/>	<input type="checkbox"/>
10. Subsurface Information		
a. Subsurface Exploration Logs	<input checked="" type="checkbox"/>	<input type="checkbox"/>
b. Undisturbed Sample Logs	<input type="checkbox"/>	<input type="checkbox"/>
c. Laboratory Test Data from Soil Samples	<input type="checkbox"/>	<input type="checkbox"/>
d. Tabulated Results of Probing	<input type="checkbox"/>	<input type="checkbox"/>
e. Tabulated Depth to Bedrock	<input type="checkbox"/>	<input type="checkbox"/>
f. Rock Core Evaluation Logs	<input type="checkbox"/>	<input type="checkbox"/>
g. Compression Test Data from Rock Samples	<input type="checkbox"/>	<input type="checkbox"/>
h. Rock Outcrop Maps	<input type="checkbox"/>	<input type="checkbox"/>
i. Granular Materials Resource Survey Reports	<input type="checkbox"/>	<input type="checkbox"/>
j. Terrain Reconnaissance Reports	<input type="checkbox"/>	<input type="checkbox"/>
11. Subsurface Information - Other Information		
a. Subsurface information from outside sources	<input type="checkbox"/>	<input type="checkbox"/>
b. Source Information - Granular Material and aggregates	<input type="checkbox"/>	<input type="checkbox"/>
c. Special Subsurface Reports	<input type="checkbox"/>	<input type="checkbox"/>
12. Anticipated Construction Schedule	<input type="checkbox"/>	<input type="checkbox"/>
13. Asbestos Information		
a. Asbestos Blanket Variances	<input type="checkbox"/>	<input type="checkbox"/>
b. Asbestos Report	<input type="checkbox"/>	<input type="checkbox"/>
14. Special Reports or Other Information:		
a. Permits	<input type="checkbox"/>	<input type="checkbox"/>
b. Design Approval Document	<input type="checkbox"/>	<input type="checkbox"/>
c. Survey Control Report	<input type="checkbox"/>	<input type="checkbox"/>
d. Wetland Compensation Report	<input type="checkbox"/>	<input type="checkbox"/>
	<input type="checkbox"/>	<input type="checkbox"/>
	<input type="checkbox"/>	<input type="checkbox"/>

¹ – All digital material is provided in ADOBE (PDF) format, unless noted above.

² – Required for all projects that have 11"x17" plan sets. See HDM Section 21.3.9.2

³ – Greyscale PDF's of sealed plans must be provided at PS&E submittal. An updated version must be provided whenever the plans are modified or amended.

(This page intentionally left blank)

SPECIAL NOTE

CONTROLLING EXPOSURE TO DIESEL EXHAUST

The Contractor shall exercise measures to protect “Sensitive Receptors” from the impacts of diesel exhaust fumes. Sensitive Receptors include, but are not limited to: hospitals, schools, daycare facilities, building fresh air or ventilation intakes, elderly housing or convalescent facilities. The Contractor shall ensure that diesel powered engines are located away from building air conditioners and windows.

The goal is to minimize exposure of Sensitive Receptors in close proximity to diesel exhaust, in terms of both concentration and time. In general, close proximity is defined as within 50 feet of a Sensitive Receptor. Mitigation techniques include positioning stationary equipment exhausts greater than 50 feet from Sensitive Receptors, extension of equipment exhausts through the use of flexible tubing; protecting building air intakes; and the use of moving operations.

Idling time for diesel powered equipment shall be limited to three consecutive minutes for delivery and dump trucks and all other diesel powered equipment except as follows:

- When a “mobile source” (vehicle) is forced to remain motionless because of traffic conditions or mechanical difficulties over which the operator has no control.
- When it is necessary to operate a loading, unloading or processing device.
- When the outdoor temperature is less than - 3°C (27°F).
- When the “mobile source” is being repaired.

Arrow panels and portable variable message signs shall be solar powered wherever possible or practical.

Whenever possible and practicable, the Contractor shall establish staging areas for diesel powered vehicles waiting to load or unload materials at the work site. Such areas shall be located where diesel emissions have the least impact on Sensitive Receptors and the general public.

(This page intentionally left blank)

SPECIAL NOTE

COORDINATION WITH THE UTILITY SCHEDULE

In addition to requirements and/or explanations contained in Sections 102-02, 102-03, 103-05, 105-06 and 107-05 of the Standard Specifications dated January 1, 2019, Section 100-Phase 5A, the Contractor is advised of the following:

All known public, private or municipal utility lines within or adjacent to the site of the work, are shown in the existing approximate locations on the project plans. The Contractor is cautioned that these locations are not guaranteed; nor is there a guarantee that all such lines in existence have been shown on the plans.

The Contractor shall conduct his operations as to prevent damage to such facilities. He shall make such explorations as may be necessary to determine the dimensions and locations of lines that may be subject to damage. Notification to the various owners of facilities shall be given in accordance with New York State Industrial Code 753.

The Contractor shall conduct his operations in accordance with all OSHA rules and regulations and in accordance with New York State Labor Law, Section 202-h, "The High Voltage Proximity Act".

The Contractor shall satisfy himself as to the exact location of utility lines and shall protect and support in a suitable manner all utilities encountered in his work. The Contractor shall make good any damage to those utilities caused by his operations. If the nature of the damage is such as to endanger the satisfactory operations of the utilities, and the necessary repairs are not immediately made by the Contractor, the work may be done by the respective owning companies and the cost thereof charged against the Contractor.

The Contractor specifically agrees that he has included in his unit prices and lump sum prices, bid for the various items of the contract, any additional cost of doing the work under this contract because of the fact that he might not have a clear site for the work and because of interference of the roadway use by the utilities and the necessity or desirability of opening certain sections of pavement to traffic before the entire work is completed.

The Contractor must coordinate his schedule of operations with the various Utility owners and/or municipalities involved with the project and shall verify utility information found in the contract documents. Utility revisions required by the various Utility owners in connection with this project include:

New York State Electric and Gas (NYSEG)

NYSEG will relocate the overhead electric lines along the south side of the bridge to the north side. This will involve relocating poles E12-L1103 and E12A to the locations consistent with the disposition of utilities worksheet and with the contract plans. In addition a new pole will be placed by NYSEG on the southwest side of the road approximately 231 ft west of the existing bridge joint. NYSEG shall be required to complete their work within three (3) weeks after receipt of the notification indicating that the site is prepared and accessible for NYSEG to start working. If determined necessary for erection of steel girder the contractor may request the utility lines to be de-energized for a maximum duration of four (4) hours. Contractor shall coordinate with NYSEG a minimum of three (3) weeks prior to the requested de-energized date.

In addition to the above itemized revisions, other additions may become necessary during the construction phase as a result of more precise location data or other changes that might develop. Suitable time frames for these additions shall be coordinated between the Contractor and the utility companies. Such time frames are not to be included within previously established time frames.

The contact at NYSEG is Paul Blakelock, 4125 Route 22, Plattsburgh, NY 12901. He may be contacted at (518) 484-3798.

Frontier Communications

Frontier Communications will relocate their overhead communication lines to the new poles installed by NYSEG as outlined in the *Disposition of Utilities Worksheet* and consistent with the contract plans. Frontier Communications shall be required to complete their work within three (3) weeks after NYSEG has relocated the poles. If a request to de-energized the electric lines has been made to NYSEG the contractor shall also notify Frontier.

In addition to the above itemized revisions, other additions may become necessary during the construction phase as a result of more precise location data or other changes that might develop. Suitable time frames for these additions shall be coordinated between the Contractor and the utility companies. Such time frames are not to be included within previously established time frames.

The contact at Frontier Communications is Dan McDermott, 137 Harrison St, Gloversville, NY 12078. He may be contacted at (518) 773-6112.

SPECIAL NOTE

DUST CONTROL

The Contractor shall minimize dust from disturbed soil surfaces or other materials that can cause off-site damage, health hazards and traffic safety problems. Dusty conditions resulting from the

Contractor's operations shall be corrected at no additional cost to the State. Buffer areas of vegetation should be left where practical. Water quality shall be considered when selecting materials for dust control. An approved dust palliative may be used in conformance with applicable conditions placed on its use. A list of acceptable dust palliatives is available at: <https://www.dot.ny.gov/divisions/engineering/technical-services/geotechnical-engineering-bureau/dust-palliatives>.

For areas not subject to traffic, products and materials may be applied or placed on soil surfaces to prevent airborne migration of soil particles, including:

- Vegetative Cover –provides the most practical method of dust control.
- Mulch (including rolled erosion control products) –provides a fast, effective method of dust control.
- Spray Adhesives –Generally composed of polymers in a liquid or solid form mixed with water to form an emulsion that is sprayed on the soil surface. The mixing ratios and application rates will be in accordance with the manufacturer’s recommendations for the specific soils on the site. Adhesives shall not be applied to wet soils or if there is a probability of precipitation within 48 hours.

For areas subject to traffic (traveling public or construction traffic) products and materials may be applied or placed on soil surfaces to prevent airborne migration of soil particles, including:

- Water Sprinkling –The site may be sprayed with water until the surface is wet. This is especially effective on haul roads and access routes.
- Polymer Additives –Polymers shall be mixed with water and applied to the driving surface using mixing ratios and application rates in accordance with the manufacturer’s recommendations. No application of the polymer will be made if there is a probability of precipitation within 48 hours of its proposed use. Any polymers must be used in accordance with the NYSDEC issued “Conditions for Use” and “Application Instructions.” This information can be obtained from the NYSDEC website.
- Barriers –Woven geotextiles or stone can be placed on the driving surface to effectively reduce dust throw and particle migration on haul roads.
- Windbreak –A silt fence or similar barrier can control air currents at horizontal intervals equal to ten times the barrier height. Preserve existing vegetation that acts as a wind barrier as much as practical.
- Wheel Washing –Mechanical or manual wet-method cleaning of on-road construction vehicle tires prior to leaving site.

(This page intentionally left blank)

SPECIAL NOTE

EMERGENCY CONTACT NUMBERS

The Contractor shall employ, for the duration of the contract, a telephone answering service to meet the requirements stated in Standard Specification Section 107-05.

The answering service shall be equipped to receive calls on a 24-hour basis and promptly contact contractor personnel with the authority and capability to mobilize forces to respond to an emergency.

The following action shall be taken after an emergency call is received.

During Normal Work Hours:

1. The Contractor's responsible person shall respond to the person or agency which initiated the call within 20 minutes from the time his answering service received it.
2. Immediately following the return call to the initiator, he should contact the Engineer advising of the situation and what action he plans to take. If the Engineer is not reachable at the Project Field Office, he should leave a message on the Engineer's answering machine and contact the following personnel in the order listed:

- 1) _____
- 2) _____
- 3) _____
- 4) _____

3. The Contractor shall respond to the emergency and make follow-up confirmatory calls as directed by the Counties' Representative or the County of Essex.

During Non-Working Hours:

1. The Contractor's responsible person shall respond to the person or agency which initiated the call within 20 minutes from the time his answering service received it. If the call initiated from a person or agency other than County of Essex, immediately notify the County of Essex of the situation and the action he plans to take by contacting the following personnel in the order listed:

- 1) _____
- 2) _____
- 3) _____
- 4) _____

2. If work is required at the project site, the Contractor's responsible person shall be at the site within one hour from the time of the initiator's original call.

(This page intentionally left blank)

SPECIAL NOTE

EMERGENCY CONTACT NUMBERS

3. Follow-up calls within two hours of the original call shall be made to the original caller and to the County of Essex advising of the status of the emergency and the action taken. At the same time, a message shall be left on the Engineer's field office answering machine with the same information.

SPECIAL NOTE

GUIDE RAIL DOWNTIME RESTRICTIONS

This contract contains restrictions on the amount of time that any run of guide rail may be out of service or that installation of new runs may be deferred. The Contractor is advised to be aware of these restrictions when preparing bids and scheduling work for this contract. Failure, as determined by the Engineer, to comply with the time frames specified will result in assessment of nonpayment for Item 619.01 Basic Work Zone Traffic Control for each calendar day during which the cited guide rail installation is not complete. In addition, liquidated damages will also be assessed at rates shown in Table 108-1 of Section 108.03.

Guide rail shall not be removed from any location where traffic is being maintained until the Contractor or Sub-Contractor is prepared to fully install the new section of rail and its terminals. The Contractor shall schedule operations to replace all rail on the same day as removed unless subsequent construction operations make it impractical to do so. Installation of the new rail shall begin as soon as practical after removal of the existing rail. Installation work on any individual location shall continue until all the railing at that location has been installed. When guide rail can not be replaced on the same day as removed, (1) the work area shall be delineated using the Overnight Shoulder Closure Details shown in the plans and (2) the guide rail shall be replaced within the guide rail replacement time duration for this contract, which is noted below:

- Same day unless temporary protection provisions made

The guide rail replacement duration for a given existing run shall be measured from the first day that dismantling of the run begins to the day of complete installation of the rail and its end assemblies.

SPECIAL NOTE

INSURANCE

This special note serves as a supplement to insurance requirements listed in the Invitation to Bidders section in this Manual and Section 107-06 of the New York State Department of Transportation Standard Specifications.

The following parties shall be named as additional insured for all those activities performed within its contracted activities for the contract as executed:

Essex County

Town of Newcomb

The State of New York and the Commissioner of Transportation and all employees of the Commissioner of Transportation

The People of the State of New York

Creighton Manning Engineering, LLP

NYSEG

Frontier Communications

Coverage must also be provided for any consultant inspecting engineer or inspector (and their agents) working for or on the project.

The above listing supplements Section 107-06 INSURANCE of the New York State Department of Transportation Standard Specifications.

(This page intentionally left blank)

SPECIAL NOTE

STATE PREVAILING WAGE RATES

The Contractor shall ensure that workers are paid the appropriate wages and supplemental (fringe) benefits. Throughout the contract, the Contractor shall obtain and pay workers in accordance with periodic wage rate schedule updates from the NYS Department of Labor (NYSDOL). Wage rate amendments and supplements are available on the NYSDOL web site at www.labor.state.ny.us. All changes or clarification of labor classification(s) and applicability of prevailing wage rates shall be obtained in writing from the Office of the Director, NYSDOL Bureau of Public Work.

The NYSDOL prevailing wage rate schedule for this contract has been determined and is available on the internet. The prevailing wage rate schedule is accessed by visiting the NYSDOL web site, navigating to the appropriate web page, and entering the Prevailing Rate Case No. (PRC#). The PRC# is provided on NYSDOL Form PW-200 included in this contract Proposal.

A copy of the project specific prevailing wage rate schedule will be provided to the successful bidder upon award of the contract. Upon written request, the schedule will be provided by the Department of Transportation to prospective bidders without internet access.

(This page intentionally left blank)

SPECIAL NOTE

OFFICE TECHNOLOGY AND SUPPLIES - TECHNICAL REQUIREMENTS FOR ITEM 637.34

The following office technology supplies shall be provided as part of the initial setup of the Engineer's Office (additional supplies will be required to be provided over the duration of the construction contract):

Note: If a specification is followed by "(minimum)" then the stated requirement or better is acceptable. Otherwise, only the stated requirement is acceptable. For accessories preceded by "(*)", the Contractor shall replenish these items as required by the Engineer and be of a type, size, quality, and capacity acceptable to the Engineer. These items shall remain the property of the Town.]

Mobile Telephone (Cellular Phone) – Quantity: 1

Technical Specifications:

The mobile telephone equipment shall meet the following requirements:

Telephone

- Handheld, transportable telephone
- Digital communications technology (if service is available, otherwise analog or other Engineer approved technology is acceptable)
- Two-way radio ('push-to-talk', 'walkie-talkie', etc.) capability (if service is available), otherwise >mobile-to-mobile= calling feature is acceptable.
- Electronic locking capability
- **Optional Feature: built-in camera (Verify with the Engineer if this feature is to be provided and on how many of the telephones)**

Accessories

- Spare battery
- AC power charging unit
- Hands-free operation accessories
- Belt clip/holster for mobile telephone
- DC power cord for in-vehicle use
- Any necessary hardware/software/cables to connect the telephone to a computer for uploading/downloading data and pictures (Note: This accessory is generally only necessary for telephones with the built-in camera feature)

Service

- 500 minutes per month telephone air time calling plan (minimum)
- 500 minutes per month two-way radio (or >mobile to mobile=) air time calling plan

SPECIAL NOTE

OFFICE TECHNOLOGY AND SUPPLIES - TECHNICAL REQUIREMENTS FOR ITEM 637.34

(minimum).

- Continuous coverage across entire contract location (or best coverage available)
- Local service -So that most on-site and regional calls are not considered long-distance calls

Desktop Computer - Quantity: 1

Computer

The supplied computer(s) shall meet the following minimum requirements:

- Operating System - Windows 7 Professional
- Processor – Intel Core i3 (2.4 GHz) or equivalent
- Memory – 4 GB RAM (minimum)
- Graphics – Intel HD integrated graphics or equivalent
- Hard Drive - Internal 320 GB (minimum)
- CD-Rom - Internal, Rewriteable DVD device (DVD-RW), 16x (minimum)
- Monitor - 20", color, LCD (minimum)
- Network Card - 10/100 cable Ethernet required or 801.11b/g compatible (optional) Mbps wireless
- Additional Hardware - Mouse, keyboard, sound card w/ speakers, 4 USB ports, 1 serial port, and 1 printer port (minimum)

Software

[*Note:* For software versions followed by an "*", supply the most current version.]

Type of Software

NYSDOT Requirement/Standard

- Office SuiteOffice 2007 (Microsoft)
- Portable Document (.pdf) ReaderAcrobat Reader 11* (Adobe) or equivalent
- Virus Protection/Computer Utilities ..AVG Anti-Virus and Internet Security or equivalent
- Virus Definition Updates For the virus protection software, it is required to maintain the virus definitions for the duration of contract, this typically requires a service subscription for the updates after the first year.
- File Compression WinZip 18* (WinZip Computing)
[*Note:* must provide a licensed copy]
- CD Creator Easy CD & DVD Creator* (Roxio) or equivalent

SPECIAL NOTE

OFFICE TECHNOLOGY AND SUPPLIES - TECHNICAL REQUIREMENTS FOR ITEM 637.34

Computer Peripherals

Provide one set of the following accessories per computer (desktop or portable) in the office:

- Surge protector - 6 power outlets, 1 telephone outlet, and 1 coaxial outlet (minimum)
- Dust covers for computer, monitor, & keyboard.
- Mouse pad
- Security cable lock(s), to secure the computer and monitor, 6 foot cable (minimum)

Multifunction Machine - Quantity: 1

This item shall include all the components, peripherals, software, and accessories specified as follows:

MULTIFUNCTION MACHINE

- Functions – Print, Scan, Copy, and FAX (minimum)
- Laser Printer
- Paper Size - Capable of handling 8 ½" x 11" and 11" x 17" paper
- Print Resolution – 600 x 600 dpi (minimum)
- Scanner Optical Resolution – 600 x 600 dpi (minimum)
- Capable of color, greyscale, and black & white scanning (minimum)
- Memory - 16 MB (minimum)
- Print Speed - 15 ppm (minimum)
- Copy Speed – 10 cpm (minimum)
- w/ postscript level 2 emulation (minimum)
- Modem – 33.6K bps FAX modem (minimum)
- Must be stand-alone and network ready (Note: the Engineer can waive the ‘network ready’ requirement if the multifunction machine will not be connected to a network.)

ACCESSORIES

- Stand/table for the multifunction machine
- Cable to connect the printer to a computer or network

Digital Camera - Quantity: 1

This item shall include all the components, peripherals, software, and accessories specified as follows:

SPECIAL NOTE

OFFICE TECHNOLOGY AND SUPPLIES - TECHNICAL REQUIREMENTS FOR ITEM 637.34

DIGITAL CAMERA

- Optical Zoom - 3X Optical Zoom Lens (minimum) [Note: digital zoom is not the same as optical zoom]
- Image Size – 8 Megapixel (minimum)
- Flash - Built-In, Intelligent (Auto/On/Off) (minimum)
- Time Stamp: Date & Time (minimum)
- Recording Media Slot – Must function with a commercially available removable memory card (CompactFlash, SmartMedia, Secure Digital, etc.) or other Engineer approved alternative.
- Viewfinder - Minimum 45 mm (1.8") diagonal

ACCESSORIES

- (*) Recording Media– Two 2 GB memory cards (CompactFlash, SmartMedia, Secure Digital, etc.) or other Engineer approved equivalent alternative (minimum)
- (*) Batteries - Two sets of rechargeable batteries, minimum 50 minute usable charge per battery set (minimum) [Recommendation: Lithium or NiMH batteries]
- Battery Charger Unit
- All cables, hardware, and software necessary to transfer the image files to a computer.
- Carry Case
- Lens Cap (if applicable)
- (*) 200 sheets of 216mm x 279mm (8 ½" x 11"), photo quality, printer paper.

Communication Services

In addition to the telephone service provided for the field office, an additional dedicated high speed communication service, with the service paid for under the Engineer's Office pay item shall be provided for the office technology equipment (computers, etc.). When there will be multiple computers in an office connected by a local area network (LAN), only a total of 2 communications service line for all the office technology equipment is required unless otherwise specified. Types of service (phone line, cable internet service, etc.) to be provided shall be identified by the Engineer with input from the appropriate construction automation support personnel.

Data Storage Media

- X (*) 20 writeable DVDs (DVD-R) (minimum)
- X (*) 50 rewriteable DVDs (DVD-RW) (minimum)
- X (*) 1 USB Flash drive
- X (*) Data media storage containers as follows:
 - ✓ 1 container for 20 DVDs, with locking capability (minimum)

SPECIAL NOTE

OFFICE TECHNOLOGY AND SUPPLIES - TECHNICAL REQUIREMENTS FOR ITEM 637.34

Mail Supplies

- (*) 10 CD-Rom protective mailers (for shipping/mailing) (minimum)
- (*) 100 laser mailing labels (minimum)

Printer Supplies

- (*) 500 sheets of 8 ½" x 11", 20# bond weight, letter quality paper (minimum)
- (*) 500 sheets of 11" x 17", 20# bond weight, letter quality paper (minimum)
- (*) 1 replacement printer toner cartridge for each printer (minimum)

(This page intentionally left blank)

SPECIAL NOTE

PRICE ADJUSTMENTS

1. ASPHALT PRICE ADJUSTMENT

The PGB Index Price which shall apply to this contract shall be \$ 514 per ton (t).

The table listed on the NYSDOT Web Site: - <https://www.dot.ny.gov/portal/page/portal/main/business-center/contractors/construction-division/fuel-asphalt-steel-price-adjustments> - lists conversion factors used in computing Asphalt Price Adjustment. Bituminous materials not listed are also eligible for asphalt price adjustment using the conversion factor of a similar listed material with the same [pay units. If an appropriate conversion factor is not apparent, the Material Bureau shall be contacted to provide this information. The conversion factors for asphalt concrete mixed with slag shall be increased by 25%. The conversion factor for truing and leveling is based on the average for top and binder mixes. The price adjustment for shim course asphalt used as truing and leveling will be computed separately using the conversion factor for bituminous concrete Type 5 (shim).

2. FUEL PRICE ADJUSTMENT

The Fuel Index Price which shall apply to this contract shall be \$ 1.70 per gallon.

The table at the NYSDOT Web Site: - <https://www.dot.ny.gov/portal/page/portal/main/business-center/contractors/construction-division/fuel-asphalt-steel-price-adjustments> - lists eligible items used in computing the Fuel Price Adjustment.

3. STEEL/IRON PRICE ADJUSTMENT

The following items/materials permanently incorporated into the work are eligible for steel and iron price adjustment:

- Structural Steel
- Reinforcing Steel (in superstructures or substructures)
- Shear Studs
- Open Steel Bridge Floor
- Tension Strands
- Dowel Bars
- Load Transfer Devices
- Steel in Precast or Prestressed Concrete Items, Including:
 - Drainage Structures and Manholes
 - Box Culverts
 - Prefabricated Bridge and Wall Elements

SPECIAL NOTE

PRICE ADJUSTMENTS

- Concrete Barrier
- Bridge, Culvert and Guide Railing
- Sheet Piling and Cofferdams
- Piling
- Utility Frames, Grates & Covers
- Overhead Sign Structures
- Ductile Iron Water Main and Ductile Iron Appurtenances
- Steel Water Main
- Poles (Signal, Power, etc)

Steel and iron price adjustments will be calculated in accordance with Section 698 *Price Adjustments*. Eligible materials include major components of items for which the weight of the steel and/or iron can be simply determined from manufacturer's/supplier's data or shipping weights, and exclude minor appurtenances individually weighing less than 2 kg (i.e. nuts, bolts, washers, etc.). Eligible precast or prestressed concrete items shall have total reinforcing steel weight listed on the approved shop drawings.

The Engineer will determine the mass of eligible materials from the following sources, in declining order of precedence; approved shop drawings, contract documents, industry standards (i.e. Steel Manual, AWWA Standards, etc.) and manufacturer's data.

The tables at the NYSDOT Web Site: -

<https://www.dot.ny.gov/portal/page/portal/main/business-center/contractors/construction-division/fuel-asphalt-steel-price-adjustments>- lists Producer Price Indexes from the USDOL Bureau of Labor Statistics (BLS) along with a listing of initial cost basis (CB) values for steel/iron products.

Steel Price Adjustment Cost Basis = \$ 824

SPECIAL NOTE

RIGHT-OF-WAY

- A. All work to be performed under this contract will be within the public right-of-way (ROW) in accordance with Section 105-15 of the Standard Specifications. The contractor is to assure himself that all work is being performed within the ROW, including but not limited to vehicle access; storage of equipment, materials, debris and waste; landscaping; vegetation removal and management; grading, seeding and the installation of turf; and the installation of any fences or protective barrier.
- B. If the contractor is unable to identify the limits of the rights-of-way when the contract calls for work in those vicinities, the contractor must contact the project engineer for definitive boundary determinations before any work may be initiated at those locations (Standard Specifications Sections 105-10 and 625).
- C. In accordance with Section 107-13 of the Standard Specifications, releases for any non-essential contract work outside of the existing rights-of-way, including plantings, landscaping or driveway enhancement, will be provided by the project engineer and in no instance are to be secured by the contractor. The contractor shall not invade upon private properties, lands or buildings outside of the rights-of-way for any reason without first securing written permission from the property owner (Standard Specifications Sections 105-15, 107-13).
- D. The contractor will be held liable for any damages done. Any such injuries or damages shall be satisfactorily repaired or items placed at the contractor's expense (Standard Specifications Section 107-08 and 107-13).

(This page intentionally left blank)

SPECIAL NOTE

SPECIAL SPECIFICATION ITEM NUMBERS

The Contractor's attention is directed to the special specification pay item formats used in this contract. Special specification pay items may be presented in two different formats:

- Format 1. Pay items appearing in the special specification will have five digits to the left of the decimal point and up to six digits to the right of the decimal point. The two left-most digits represent the origin of the specification. Reference Standard Specification §101-02 Specifications.

- Format 2. Pay items appearing in the special specification will have three digits to the left of the decimal point and up to eight digits to the right of the decimal. The seventh and eight digits to the right of the decimal will represent the origin of the specification.

Where items in this contract appear in multiple formats, one format shall be equated to the other format as illustrated below:

<u>Format 1</u>	<u>Format 2</u> *	<u>Format 3</u>
XXXXX.XX	XXX.XXbbbbXX	XXX.XX0000XX
XXXXX.XXXX	XXX.XXXXbbXX	XXX.XXXX00XX
XXXXX.XXXXXX	XXX.XXXXXXXX	XXX.XXXXXXXX

* "b" represents a blank space which will appear when all six digits of the pay item are not used.

(This page intentionally left blank)

SPECIAL NOTE
SUPERPAVE HOT MIX ASPHALT PERFORMANCE SPECIAL NOTE

Steps

1. Develop Mix design
2. Go to NYSDOT Materials Bureau:
<https://www.dot.ny.gov/divisions/engineering/technical-services/materials-bureau/hma-specialnotes>
3. Copy appropriate special note from NYSDOT listing into your project directory

(This page intentionally left blank)

SPECIAL NOTE
TEMPORARY LANE CLOSURE RESTRICTIONS FOR MAJOR HOLIDAYS
(2019 & 2020)

There shall be no temporary lane closures on roadway facilities owned and/or maintained by NYSDOT on the major holidays listed below.

Exceptions can only be made under the following conditions:

- Emergency work
- Work within long-term stationary lane closures
- Safety work that does not adversely impact traffic mobility and has been authorized by the Office of Traffic Safety & Mobility

Construction activities that will result in temporary lane closures shall be suspended to minimize travel delays associated with road work for major holidays as follows:

2019

<u>New Year's Day</u> - Tuesday January 1.	Beginning 6:00 AM Friday, December 28 and ending 6:00 AM Wednesday, January 2
<u>Memorial Day</u> - Monday May 27.	Beginning 6:00 AM Friday, May 24 and ending 6:00 AM Tuesday, May 28.
<u>Independence Day</u> - Thursday July 4.	Beginning 6:00 AM Wednesday, July 3 and ending 6:00 AM Monday, July 8.
<u>Labor Day</u> - Monday, September 2.	Beginning 6:00 AM Friday, August 30 and ending 6:00 AM Tuesday, September 3.
<u>Thanksgiving Day</u> - Thursday, November 28.	Beginning 6:00 AM Wednesday, November 27 and ending 6:00 AM Monday, December 2
<u>Christmas Day</u> - Wednesday, December 25.	Beginning 6:00 AM Tuesday, December 24 and ending 6:00 AM Thursday, December 26.

2020

<u>New Year's Day</u> – Wednesday January 1.	Beginning 6:00 AM Tuesday, December 31 and ending 6:00 AM Thursday, January 2
<u>Memorial Day</u> - Monday May 25.	Beginning 6:00 AM Friday, May 22 and ending 6:00 AM Tuesday, May 26.
<u>Independence Day</u> - Saturday July 4.	Beginning 6:00 AM Friday, July 3 and ending 6:00 AM Monday, July 6.
<u>Labor Day</u> - Monday, September 7.	Beginning 6:00 AM Friday, September 4 and ending 6:00 AM Tuesday, September 8.
<u>Thanksgiving Day</u> - Thursday, November 26.	Beginning 6:00 AM Wednesday, November 25 and ending 6:00 AM Monday, November 30.
<u>Christmas Day</u> - Friday, December 25.	Beginning 6:00 AM Thursday, December 24 and ending 6:00 AM Monday, December 28.

(This page intentionally left blank)

SPECIAL NOTE

ULTRA LOW SULFUR DIESEL FUEL

In order to reduce diesel emissions, the Contractor shall use Ultra Low Sulfur Diesel (ULSD) fuel to operate all diesel engines used to complete the work that will operate for 10 hours or more on the contract site. ULSD fuel requirements shall apply to:

- All diesel engines/equipment
- Stationary and mobile equipment
- Owned, leased and rented equipment.

The hours the piece of equipment is used to complete the work is defined as the actual time the engine is running. The time may be continuous or discontinuous and includes warm-up periods idling, in traffic periods, etc.

The term "Contractor" is intended to mean both Prime Contractors and Subcontractors. Materials delivery vehicles not owned by the Contractor/Subcontractor are exempt from this requirement, but should minimize idling time at construction sites when ever possible.

The Contractor will be notified when any diesel powered construction equipment is in noncompliance. Non-compliance shall be corrected within a 24-hour period.

(This page intentionally left blank)

SPECIAL NOTE

OPTIONAL USE OF WARM MIX ASPHALT (WMA) TECHNOLOGIES

The contractor has the option of using an Approved WMA Technology in the production of all 402, Hot Mix Asphalt (HMA) items, except SUPERPAVE HMA with Ice Retardant items, Waterproofing Bridge Deck HMA items, and Paver-Placed Surface Treatment items, at no additional cost to the State.

If the contractor chooses to use a WMA technology, the provisions of §401 and §402 shall apply including the following:

Use an approved technology appearing on the Approved List for Technologies for Warm Mix Asphalt. Design a mixture using a WMA Technology in accordance with MM 5.16, Superpave Hot Mix Asphalt Mixture Design and Mixture Verification Procedure. At a minimum, a one point verification of the mixture's volumetric properties is acceptable for the following situations:

- When the WMA mix design is based on an existing Production Status HMA mix design.
- When the WMA mix design is based on, and utilizes a different WMA technology than, an existing Production Status WMA mix design.

Comply with the latest manufacturer's "Production, Testing, and Compaction Details" from the Approved List for incorporating the WMA technology. Test specimens may be made from plant produced or laboratory prepared WMA. Test specimens must be made from plant produced WMA if adding the WMA technology in the lab does not simulate the production process. The Regional Materials Engineer (RME) may require a State representative be present during the fabrication and testing. Submit the WMA design to the RME for review and verification at least 14 calendar days before production, including:

- Name of WMA technology and the target dosage rate.
- If using an additive other than water,
 - Submit a MSDS for the additive.
 - Submit either enough of the additive for the laboratory mix design verification, or the additive pre-blended in the PG Binder at the correct dosage. If the additive is not pre-blended into the PG Binder, include directions for properly incorporating the additive into the laboratory made mixture.
- Prior to the submission of any mix design, contact the RME to determine if there is an increased concern regarding the mixture's moisture susceptibility based on the WMA technology and/or the type of aggregate being used, or the performance of similar mixes. The RME may require AASHTO T 283 moisture susceptibility test results, meeting a minimum Tensile Strength Ratio (TSR) of 80%, as part of the mix design submission.

(This page intentionally left blank)

SPECIAL NOTE

OPTIONAL USE OF WARM MIX ASPHALT (WMA) TECHNOLOGIES

Submit Production Quality Control Plan revisions incorporating the WMA technology if not previously submitted.

For 80 Series Compaction Method, complete all breakdown roller passes before the mat temperature falls below 230° F, unless approved by the Director, Materials Bureau.

When the asphalt mixture is being placed over a Sheet-Applied Waterproofing Membrane, maintain a minimum delivery temperature in accordance with the Material Detail Sheets prepared by the membrane manufacturer.

SPECIAL NOTE

PG BINDER AND MIX DESIGN LEVEL

Requirements of this note apply to all Section 402 and Section 404 Asphalt (HMA and WMA) items in this contract, except for shim, permeable base, temporary pavements, and miscellaneous, which may use non-modified PG binders such as PG 64S-22 and PG 64H-22.

PG BINDER

Use polymer or Terminal Blend Crumb Rubber modified **PG 58E-34** (Extreme) meeting the requirements of AASHTO M 332, *Standard Specification for Performance Graded Asphalt Binder using Multiple Stress Creep Recovery (MSCR)*, for the production of hot mix asphalt mixtures for this project. In addition, the binder grade must also meet the **elastomeric** properties as indicated by one of the following equations for %R_{3.2}:

1. For $J_{nr3.2} \geq 0.1$, $\%R_{3.2} > 29.371 * J_{nr3.2}^{-0.2633}$
2. For $J_{nr3.2} < 0.1$, $\%R_{3.2} > 55$

Where

R_{3.2} is % recovery at 3.2 kPa

J_{nr 3.2} is the average non-recoverable creep compliance at 3.2 kPa

When terminal blend CRM PG binder is used, the following shall apply:

- Crumb rubber particles shall be finer than #30 sieve size.
- The CRM PG binder shall be storage-stable and homogeneous.
- The Dynamic Shear Rheometer (DSR) shall be set at 2-mm gap.
- The CRM PG binder shall be 99% free of particles retained on the 600 µm sieve as tested in accordance with Section 5.4 of M 332.

Use of polyphosphoric acid (PPA) to modify the PG binder properties is prohibited for mixtures under this contract. This prohibition also applies to the use of PPA as a cross-linking agent for polymer modification.

MIX DESIGN

The mixture designs must be developed in accordance with the criteria specified in the HMA items that are appropriate for the Mixture Design Level of **50 Gyration**s.

Note: The PG binder for this project will be modified with polymer or CRM additives to meet the requirements stated above. Handling of the HMA shall be discussed at pre-construction and pre-paving meetings.

P.I.N. 1760.68

TURF ESTABLISHMENT - SEED MIX AS SPECIFIED

ITEM 610.16XXNN24 - TURF ESTABLISHMENT - SEED MIX AS SPECIFIED

610-1 Description			
-1.02 Establishing Turf			
Station to Station	Side	Quantity	Remarks
Contract Limits	Lt & Rt	597y ²	Establishing turf will be as shown on the plans, details, typical sections, tables, Contract Documents and as ordered by the Engineer. (A.O.B.E.).
Total square yard		597y ²	
610-2 Materials			
-2.02 Seeding Material			
Seeds:		713-04 and as indicated in detail specifications table	
Fertilizer		713-03 Type No. 3 (1-1-1, 50% N/FU)	
Mulch:		713-19 Straw	
Mulch Anchorage:		713-12 Mulch Anchorage, Type A	
610-3 Construction Details			
-3.02 A. Rates:			
Seed		See specific seed mix for rate.	
Fertilizer		90 grams of nitrogen / m ²	
Mulch:		Straw Mulch; 0.5 kg/m ² Firm seed bed prior to mulch	
Mulch Anchorage:		As per the manufacturer's recommendation	
Limestone:		3g/ 26.35 sm (25 lb/ 1000 sq. ft.)	
-3.02 D. Ground Preparation and Seeding:			
As per the Standard Specifications.			
Method No. 2 shall be used to establish turf in front of all areas near residential or commercial buildings			
Method No. 1 shall be used in all other areas.			
In those areas where topsoil is not specified, the areas to be seeded shall be scarified or tilled to a minimum depth of 150mm immediately before seeding, unless otherwise directed by the Engineer.			

>>>DETAIL SPECIFICATIONS FOR SEEDS <<<
SEE BELOW

Seed Mix "A" – Native Roadside Seed Mix

A= Approx. % by Seed Count

Species	Variety	A
Virgina Wild Rye (<i>Elymus virginicus</i>)	Commercial	5.00%
Panicledleaf Tick Trefoil (<i>Desmodium paniculatum</i>)	Commercial	0.56%
Little Bluestem (<i>Schizachyrium scoparium</i>)	Commercial	11.67%
Big Bluestem (<i>Andropogon gerardii</i>)	Commercial	7.78%
Creeping Red Fescue (<i>Festuca rubra</i>)	Commercial	23.89%
Indian Grass (<i>Sorghastrum nutans</i>)	Commercial	7.78%
Switch Grass (<i>Panicum virgatum</i>)	Commercial	5.59%
Staghorn Sumac (<i>Rhus typhina</i>)	Commercial	0.56%
Grey Dogwood (<i>Cornus racemosa</i>)	Commercial	0.00%
Silky Dogwood (<i>Cornus amomum</i>)	Commercial	0.00%
Evening Primrose (<i>Oenothera biennis</i>)	Commercial	15.56%
Butterfly Milkweed (<i>Asclepias tuberosa</i>)	Commercial	0.56%

Black Eyed Susan (<i>Rudbeckia hirta</i>)	Commercial	13.89%
Partridge Pea (<i>Chamaecrista fasciculata</i>)	Commercial	0.56%
Hollow-Stem Joe Pye Weed (<i>Eupatorium fistulosum</i>) (<i>Eutrochium fistulosum</i>)	Commercial	6.67%

(This page intentionally left blank)

V. SPECIFICATIONS

A. SPECIFICATIONS

The State of New York Department of Transportation Office of Engineering *Standard Specifications, Construction and Materials*, including any addenda to date, updated quarterly to date, are hereby incorporated, in their entirety, and made a composite part of these specifications except as herewith modified and supplemented by these specifications and subsequent documents issued by Essex County.

The Specifications, Plans and Contract Documents of the County shall govern over those of other agencies but where the method of work and requirements of materials are not included in the Contract Documents of the County, the State of New York Department of Transportation *Standard Specifications, Construction and Materials*, including any addenda, updated quarterly to date, shall govern.

The Contractor should note that the Project Plans are dimensioned in US Customary (English) units only, and that all Payment Items will be measured and paid in standard US Customary (English) units.

The Engineer for Essex County or his authorized representative shall make the final interpretations of any irregularities, ambiguities or questions arising out of these specifications and the New York State Department of Transportation *Standard Specifications, Construction and Materials* used on this project. References to the County's representative and County personnel shall hereinafter be made as the "Engineer".

B. DEFINITIONS

Refer to Chapter I. B.2 for Definitions and terms.

Whenever the words directed, required, permitted, ordered, instructed, designated, considered necessary, or where the words of like import are used, it shall be understood that the direction, requirement, permission, order, instruction, designation or prescription of the Engineer is intended; and similarly, the words approved, acceptable, satisfactory, or words of like import shall mean approved by or acceptable or satisfactory to the Engineer, unless another meaning is plainly intended. Whenever, in the description of any part of the Work to be done under this Contract, the expression as shown, as shown on the plans or the words of like import are used, it shall be understood to mean as shown on the Contract Drawings, unless another meaning is plainly intended.

(This Page Intentionally Left Blank)

C. SPECIAL SPECIFICATIONS

The following Special Specifications are contained in this project:

Item	Description	Unit
203.01920007	WETLAND RESTORATION	CY
559.18960118	PROTECTIVE SEALING OF STRUCTURAL CONCRETE ON NEW BRIDGE DECKS AND BRIDGE DECK OVERLAYS	SF
607.41010010	TEMPORARY PLASTIC BARRIER FENCE	LF
610.16010424	TURF ESTABLISHMENT – SEED MIX AS SPECIFIED	SY
627.50140008	CUTTING PAVMENT	LF

(This page intentionally left blank)

ITEM 203.01920007 - WETLAND RESTORATION

DESCRIPTION:

The work consists of the removal and stockpiling of existing wetland soils from designated wetlands including their temporary protection and seeding. The work also consists of the scarification of the soils to be left in place, the placement of stockpiled wetland soils, and the seeding of the restored wetland areas.

The removal of any existing road metal and berm, causeway, and bridge abutments to the proposed grades shall be paid for under separate items.

All work is to be accomplished in accordance with the specifications, plans, and as ordered by the Regional Landscape Architect or Project Engineer.

MATERIALS:

Excavated wetland soils shall be the top 12 inches of soil.

Fertilizer shall conform to the requirements of Section 713-03 of the Standard Specifications.

Mulch shall conform to the requirements of Section 713-19 of the Standard Specifications.

Mulch Anchorage shall conform to the requirements of Section 713-12 of the Standard Specifications.

See Section A of this Specification for the seed mixture for all temporary seeding, to include the wetland soil stockpile(s). See Section B of this Specification for the seed mixture for the final restoration of wetland areas. Other seeding shall conform to Item 610.0203, Establishing Turf.

Wetland plant materials shall conform to the requirements of Section 713-06 - Trees, Shrubs and Vines, of the Standard Specifications.

CONSTRUCTION DETAILS:

A. Site Layout:

The contractor shall submit to the Regional Landscape Architect a description of the methodology and equipment to be utilized to complete the work.

Before the start of any field operations, the limits of all work areas (including the access routes), shall be staked out by the Contractor under the direction of the Regional Landscape Architect. The wetland soils source area(s), see plan sheets, are located within the proposed highway corridor. Access to the stockpile area from these source area(s) shall be, to the maximum extent possible, limited to the proposed construction corridor and existing highway system.

ITEM 203.01920007 - WETLAND RESTORATION

Upon review and acceptance of the Contractor's proposed work plan, the Regional Landscape Architect will notify the Project Engineer that the Contractor may begin work within the designated wetland areas.

B. Removal, Stockpiling, Protection and Seeding of Wetland Soils:

Soil removal shall be to a nominal depth of 12 inches, or as conditions permit. All excavation from the existing wetland site shall be performed between April 1 and September 30 in order to ensure the successful seeding of stockpiled and exposed wetland areas.

Exposed wetland areas shall be seeded with Seed Mix A within 5 days of exposure, unless construction operations will commence within these areas within 14 days. If construction operations are suspended, exposed areas shall be temporarily seeded with Seed Mix A within 5 working days. Restored and reclaimed wetland areas shall be seeded and mulched with the specified Seed Mix B within 7 days of final grading.

The wetland soils shall be stockpiled in areas as shown on the Plans or as designated by the Regional Landscape Architect. Stockpiled soil is to be placed in as low a mound as possible, (not to exceed 10 ft in height), then seeded with Seed Mix A and protected around the perimeter by the specified erosion control devices.

DETAIL SPECIFICATIONS FOR SEEDS

SEED MIX A

A - Min. Germination B - Min % Germination & Hard Seed
C - # Pure Live Seed/Acre

<u>Name</u>	<u>Variety</u>	<u>A</u>	<u>B</u>	<u>C</u>
Annual Ryegrass (Lolium multiflorum)	Commercial	85		50
Annual Bluegrass (Poa annua)	Commercial	85		20

Total # Pure Live Seed per Acre = 70

ITEM 203.01920007 - WETLAND RESTORATION

DETAIL SPECIFICATIONS FOR SEEDS

SEED MIX B

A - Min. Germination B - Min % Germination & Hard Seed

C - # Pure Live Seed/Acre

<u>Name</u>	<u>Variety</u>	<u>A</u>	<u>B</u>	<u>C</u>
Annual Ryegrass (Lolium multiflorum)	Commercial	90		15
Perennial Ryegrass (Poa annua)	Commercial	90		50
Redtop (Agrostis gigantea roth)	Commercial	85		35

Total # Pure Live Seed/Acre = 100

Fertilizer: 713-03 Type No. 1 (1-2-1)

Mulch: 713-19 Straw or Approved Alternate

Mulch Anchorage: 713-12 Chemical Mulch Binders as Approved Rates --

Fertilizer: 80 # of available Nitrogen per acre

Seed: Seed Mix A 70 # of pure live seed per acre
Seed Mix B 100 # of pure live seed per acre

Mulch: Straw – 2 tons/acre (approximately 0.1 # per square ft) to completely cover the ground A.O.B.E. Straw shall be chopped at central location and placed by hand. Approved alternate shall be placed according to manufacturer's directions

Mulch Anchorage: Manufacturer's recommended rate.

C. Reestablishment:

The reestablishment area, see plan sheets, shall be excavated to a depth 12 inches below finished grade, rough graded, and scarified to a minimum depth of 6 inches prior to the placement of wetland soils. This does not apply to the hydric soil bench created at the base of the new bridge approach slopes as depicted on the Typical Section, entitled Reconstruction with Guide Rail and Wetlands Slope Treatment.

(This page intentionally left blank)

ITEM 203.01920007 - WETLAND RESTORATION

All newly established areas shall be covered with 12 inches of soil from the existing wetland soils stockpile.

The new areas created within the existing roadway corridor shall be graded to conform to adjacent land elevations and drainage patterns in conformance with the Grading Plan. The finished grade need not be smoother than necessary for planting and seeding operations as directed by the Regional Landscape Architect.

The area(s) used for soil storage shall be graded to remove any ruts caused by the Contractor's equipment or procedures and seeded with the specified seed mix under Item 610.0203, Establishing Turf.

METHOD OF MEASUREMENT:

This work will be measured as the number of cubic yards of wetland soil placed.

BASIS OF PAYMENT:

The price bid per cubic yard shall include the cost of furnishing all labor, materials, and equipment necessary to complete the work as specified, including removal, stockpiling, temporary seeding, protection and placement of stockpiled wetland soils.

Removal of the bridge abutments, existing and abandoned roadways, including pavement and embankment, shall be paid for under Item 203.02, Unclassified Excavation and Disposal.

Final seeding for wetland soil storage areas shall be paid for under Item 610.0203, Establishing Turf.

Fifty (50%) percent of the price bid per cubic yard will be paid following the removal, stockpiling, and temporary seeding of the wetland soils.

All perimeter erosion control materials for stockpiled wetland soils shall be paid for under Item 209.13, Temporary Sediment Control Fence and Item 615.0402--08, Tree/Vegetation Protection Barrier.

Woody wetland plant materials shall be paid for under Section 611 - Planting.

(This page intentionally left blank)

**ITEM 559.18960118 - PROTECTIVE SEALING OF STRUCTURAL CONCRETE ON
NEW BRIDGE DECKS AND BRIDGE DECK OVERLAYS**

DESCRIPTION. Under this work the Contractor shall furnish and apply, in accordance with this specification, a protective sealer to concrete surfaces, at locations indicated on the plans or where directed by the Engineer.

MATERIALS. The protective sealer used on new concrete bridge decks shall be one appearing on the Department's Approved List, which does not contain an aqueous solvent/carrier and shall meet the requirements of the following subsection:

717-03 - Penetrating Type Protective Sealers

CONSTRUCTION DETAILS.

- A. General.** The Contractor shall provide the Engineer with the sealer manufacturer's written instructions for application and use, at least five (5) working days before the start of work. Only one (1) brand and specific type of sealer will be allowed for use on each deck.
- B. Surface Preparation.** All concrete bridge decks shall air dry for twenty-four (24) hours after the time of completion of saw cut grooving. If the concrete is subjected to rain or moisture from other project operations, the drying period shall be extended twenty-four (24) hours from the time that the concrete has stopped being wetted. All required surface texturing, saw cut grooving, barriers, parapets, sidewalks and safetywalks shall be completed, before the surface is cleaned. After the drying period has ended, the concrete surface shall be cleaned by vacuum methods, to remove loose particles.

After cleaning, no laitance, standing water, oil, dirt or other foreign particles shall be present, which may prevent penetration of the sealer. All surface preparation work shall be completed and approved by the Engineer before sealer application can commence.

- C. Weather Limitations.** Sealer materials shall not be applied during wet weather conditions or when adverse weather conditions are anticipated within twelve (12) hours of the completion of sealer application. Ambient and surface temperatures, during application, and until the sealed concrete is dry to the touch, shall be a minimum of 40°F. Application by spray methods will not be permitted during windy conditions, if in the opinion of the Engineer, unsatisfactory results will be obtained.
- D. Sealer Application.** The protective sealer shall be used as supplied by the Manufacturer without thinning or alteration. Equipment for sealer application shall be clean of foreign materials and approved by the Engineer before use. The sealer shall be applied by brushing, spraying or rolling, as recommended by the Manufacturer.

A minimum of two (2) coats of the sealer shall be applied to achieve uniform coverage. The total quantity of sealer applied by all coats shall be equal to the quantity required at the application rate specified in the Approved List. The second and each additional coat shall be applied perpendicular to the previous coat. Care shall be taken when applying

**ITEM 559.18960118 - PROTECTIVE SEALING OF STRUCTURAL CONCRETE ON
NEW BRIDGE DECKS AND BRIDGE DECK OVERLAYS**

each coat, such that running or puddling does not occur. Each coat shall be allowed to dry for a minimum of two (2) hours before the next coat is applied. The final coat shall be allowed to dry according to the Manufacturer's instructions, before the removal of maintenance and protection of traffic.

METHOD OF MEASUREMENT. The work will be measured as the number of square feet of concrete sealed.

BASIS OF PAYMENT. The unit price bid per square feet shall include the cost of furnishing all labor, materials, and equipment necessary to satisfactorily complete the work.

ITEM 607.41010010 - TEMPORARY PLASTIC BARRIER FENCE

DESCRIPTION

This work shall consist of furnishing, installing, and maintaining Temporary Plastic Barrier Fences of the type and at the locations shown in the plans or where directed by the Engineer.

MATERIALS

Materials for Temporary Plastic Barrier Fences shall meet the following requirements:

- **Fence:** High-density polyethylene mesh, ultraviolet-stabilized min. 2 years; minimum height 4.0 feet. Color: high-visibility orange or green. When used to protect trees or other vegetation, color shall be high-visibility orange.
- **Posts:** Rigid metal or wood posts, minimum length 6.0 feet.
- **Ties:** Steel wire, #14 gauge or nylon cable ties.
- **Warning signs:** Sheet metal, plastic or other rigid, waterproof material, 1.5 feet by 2.0 feet with 4 inch black letters on a white background. Text shall be: "Protected Site - Keep Out" unless otherwise specified.

CONSTRUCTION DETAILS

Fences shall be erected prior to moving construction equipment onto any area designated for protection.

The line of fences as indicated on the plans shall be staked or marked out on the ground by the Contractor and approved by the Engineer before any fence is installed. Where used for protection of individual trees, fence shall be placed at the drip line (extent of canopy). If not possible, placement shall be as close to the drip line as possible and in no case less than 5.0 feet away from the tree trunk.

On approval of the stakeout, posts shall be securely driven on 6.0 foot-maximum centers, normal to the ground, to a depth 1/3 of the total post length. Plastic barrier fence shall be placed along the side of all posts. Ends of fencing segments shall overlap a distance of at least one half the fence height.

Fencing shall be secured to posts with wire or cable ties at top, middle and bottom of post. Fastener shall be tight enough to prevent the fencing from slipping down. Overlaps shall also be securely fastened.

Barrier fence which is not orange in color shall be flagged at 6.0 foot intervals with red or orange florescent tape. Warning signs shall be mounted on the fence at no more than 100 foot intervals.

Maintenance shall commence immediately after erection of the fence and continue until one week prior to acceptance of the contract, and shall consist of: replacing damaged post(s) and fencing; re-fastening and tightening fencing; and restoring fence to its intended height.

Fencing used for tree or other vegetation protection shall not be temporarily removed to allow equipment access over a protected area, except as required for items of work specifically shown on the plans and approved by the Engineer in writing.

ITEM 607.41010010 - TEMPORARY PLASTIC BARRIER FENCE

METHOD OF MEASUREMENT

The quantity to be measured for payment will be the number of feet of Temporary Plastic Barrier Fence erected, measured along the top, to the nearest whole foot.

BASIS OF PAYMENT

The unit price bid shall include the cost of all labor, materials and equipment necessary to satisfactorily complete the work. Relocation of a fence from one location to another as directed by the Engineer shall be considered as a new location and will be separately paid.

Seventy percent (70%) of the price bid will be paid after satisfactory installation of the fence. The remaining Thirty percent (30%) will be paid after complete removal of the fence.

ITEM 610.16XXNN24 - TURF ESTABLISHMENT – SEED MIX AS SPECIFIED

DESCRIPTION

This work shall consist of furnishing, placing and establishing a turf seed mix at the locations shown in and in accordance with the contract documents as directed by the Engineer.

All information indicated in this specification as being "...as specified in the contract documents" will be contained in a special note titled, "*Turf Establishment – Seed Mix As Specified*" in the contract documents.

MATERIALS

The following sections of the standard specifications shall apply:

Turf Establishment 610-2.03

with the following exceptions:

- the seed mix shall be as specified in the contract documents.

CONSTRUCTION DETAILS

The following sections of the standard specifications shall apply:

Turf Establishment 610-3.03

with the following qualifications:

- The application rate of the seed mix shall be as specified in the contract documents.
- Initial watering shall be a minimum 1" depth of water applied over all seeded areas.
- The acceptance criteria shall be indicated in the contract documents as one of the following:
 - §610-3.03 A. **Turf Establishment – Roadside**, or
 - §610-3.03 B. **Turf Establishment – Lawns**, or
 - **Turf Establishment – Mowing not Included**. Areas will be accepted when:
 - free from thin or bare ground greater than one foot in diameter,
 - ground surface is covered with established specified permanent turf species at a uniform density of at least eighty percent (80%),
 - turf growth height of at least eight inches (8"), and
 - turf exhibits healthy green color.
 - **Turf Establishment – Permit Requirements**. Areas will be accepted when:
 - free from thin or bare ground greater than one foot in diameter or compliant with permit requirements,
 - the ground surface is covered with established specified permanent vegetative species at a uniform density of at least eight percent (80%), or compliant with permit requirements,
 - compliant with permit conditions not listed here, and
 - determined healthy (visual inspection) as indicated by color and vigorous growth.

ITEM 610.16XXNN24 - TURF ESTABLISHMENT – SEED MIX AS SPECIFIED

METHOD OF MEASUREMENT

The work will be measured as the number of square yards on slope to the nearest whole square yard on slope of turf seed mix furnished, placed and established.

BASIS OF PAYMENT

The unit price bid for turf establishment - seed mix as specified shall include the cost of all labor, materials and equipment including initial water, mulch and mulch anchorage as necessary to satisfactorily complete the work.

Where:

XX indicates the region using the specification (e.g. 05 for Region 5; 10 for Region 10), and NN is a serialization for each unique turf seed mix established using this specification.

ITEM 627.50140008 - CUTTING PAVEMENT

DESCRIPTION:

The contractor shall cut existing asphalt pavement, concrete pavement, asphalt surface course, or asphalt concrete overlay on concrete pavement at the locations indicated and detailed on the plans and as directed by the Engineer.

MATERIALS:

None specified.

CONSTRUCTION DETAILS:

Existing pavement and overlay shall be cut perpendicular to the roadway surface along neat lines, and to the depth indicated on the plans and typical sections, using appropriate equipment. After the pavement has been cut through, the Contractor may use pry bars, pneumatic tools or other methods, to pry loose the pavement to be removed from the pavement that is to remain. A pavement breaker may be used to break up the pavement to be removed after the pavement has been completely cut through and completely free from the pavement to remain.

When pavement cutting is called for in the Contract documents, if a neat vertical face with minimal shatter is obtained by performing an adjacent operation (such as milling) which eliminates the need to perform a separate pavement cutting operation, payment will be made for both the pavement cutting item and the item for the adjacent operation.

Any existing pavements and curbs not indicated to be removed that are damaged by the contractor's operations, shall be repaired at no additional cost to the State. Pavement cutting that the contractor chooses to do for his/her own convenience shall not receive any additional payment from the State.

METHOD OF MEASUREMENT:

The quantity to be measured will be the number of linear feet of pavement cutting satisfactorily completed.

BASIS OF PAYMENT:

The unit price bid per linear foot of pavement cutting shall include the cost of all labor, materials, and equipment necessary to satisfactorily complete the work.

Payment for prying, breaking, removal and disposal of cut pavement shall be made through other appropriate items.

(This page intentionally left blank)

Chapter VI FEDERAL AND STATE LABOR REQUIREMENTS

VI. Federal (Davis-Bacon) Wage Rates

See enclosed wage rates.

State Wage Rates:

The CONTRACTOR is advised that the latest Schedules of the Prevailing Hourly Wage Rates and the Prevailing Hourly Supplements as published by the State of New York, Department of Labor, Bureau of Public Works are a part of these Contract Documents. The Contractor is also advised that the Rates are subject to change during the course of the project and must be updated accordingly.

For additional information see the **Special Note – State Prevailing Wage Rates and** <http://www.labor.ny.gov/workerprotection/publicwork/PWContents.shtm>

(This page intentionally left blank)



Andrew M. Cuomo, Governor

Roberta Reardon, Commissioner

Essex County DPW
Lucas Short, Assistant Project Engineer
Creighton Manning LLP
2 Winners Circle
Albany NY 12205

Schedule Year 2018 through 2019
Date Requested 01/22/2019
PRC# 2019000892

Location .6 miles N of State Route 28N
Project ID# PIN 1760.68
Project Type Campsite Road over the Hudson River Bridge Replacement in the Town of Newcomb, Essex County, New York.

PREVAILING WAGE SCHEDULE FOR ARTICLE 8 PUBLIC WORK PROJECT

Attached is the current schedule(s) of the prevailing wage rates and prevailing hourly supplements for the project referenced above. A unique Prevailing Wage Case Number (PRC#) has been assigned to the schedule(s) for your project.

The schedule is effective from July 2018 through June 2019. All updates, corrections, posted on the 1st business day of each month, and future copies of the annual determination are available on the Department's website www.labor.state.ny.us. Updated PDF copies of your schedule can be accessed by entering your assigned PRC# at the proper location on the website.

It is the responsibility of the contracting agency or its agent to annex and make part, the attached schedule, to the specifications for this project, when it is advertised for bids and /or to forward said schedules to the successful bidder(s), immediately upon receipt, in order to insure the proper payment of wages.

Please refer to the "General Provisions of Laws Covering Workers on Public Work Contracts" provided with this schedule, for the specific details relating to other responsibilities of the Department of Jurisdiction.

Upon completion or cancellation of this project, enter the required information and mail **OR** fax this form to the office shown at the bottom of this notice, **OR** fill out the electronic version via the NYSDOL website.

NOTICE OF COMPLETION / CANCELLATION OF PROJECT

Date Completed: _____ Date Cancelled: _____

Name & Title of Representative: _____

Phone: (518) 457-5589 Fax: (518) 485-1870
W. Averell Harriman State Office Campus, Bldg. 12, Room 130, Albany, NY 12240

General Provisions of Laws Covering Workers on Article 8 Public Work Contracts

Introduction

The Labor Law requires public work contractors and subcontractors to pay laborers, workers, or mechanics employed in the performance of a public work contract not less than the prevailing rate of wage and supplements (fringe benefits) in the locality where the work is performed.

Responsibilities of the Department of Jurisdiction

A Department of Jurisdiction (Contracting Agency) includes a state department, agency, board or commission; a county, city, town or village; a school district, board of education or board of cooperative educational services; a sewer, water, fire, improvement and other district corporation; a public benefit corporation; and a public authority awarding a public work contract.

The Department of Jurisdiction (Contracting Agency) awarding a public work contract MUST obtain a Prevailing Rate Schedule listing the hourly rates of wages and supplements due the workers to be employed on a public work project. This schedule may be obtained by completing and forwarding a "Request for wage and Supplement Information" form (PW 39) to the Bureau of Public Work. The Prevailing Rate Schedule MUST be included in the specifications for the contract to be awarded and is deemed part of the public work contract.

Upon the awarding of the contract, the law requires that the Department of Jurisdiction (Contracting Agency) furnish the following information to the Bureau: the name and address of the contractor, the date the contract was let and the approximate dollar value of the contract. To facilitate compliance with this provision of the Labor Law, a copy of the Department's "Notice of Contract Award" form (PW 16) is provided with the original Prevailing Rate Schedule.

The Department of Jurisdiction (Contracting Agency) is required to notify the Bureau of the completion or cancellation of any public work project. The Department's PW 200 form is provided for that purpose.

Both the PW 16 and PW 200 forms are available for completion [online](#).

Hours

No laborer, worker, or mechanic in the employ of a contractor or subcontractor engaged in the performance of any public work project shall be permitted to work more than eight hours in any day or more than five days in any week, except in cases of extraordinary emergency. The contractor and the Department of Jurisdiction (Contracting Agency) may apply to the Bureau of Public Work for a dispensation permitting workers to work additional hours or days per week on a particular public work project. There are very few exceptions to this rule. Complete information regarding these exceptions is available on the "[4 Day / 10 Hour Work Schedule](#)" form (PW 30.1).

Wages and Supplements

The wages and supplements to be paid and/or provided to laborers, workers, and mechanics employed on a public work project shall be not less than those listed in the current Prevailing Rate Schedule for the locality where the work is performed. If a prime contractor on a public work project has not been provided with a Prevailing Rate Schedule, the contractor must notify the Department of Jurisdiction (Contracting Agency) who in turn must request an original Prevailing Rate Schedule form the Bureau of Public Work. Requests may be submitted by: mail to NYSDOL, Bureau of Public Work, State Office Bldg. Campus, Bldg. 12, Rm. 130, Albany, NY 12240; Fax to Bureau of Public Work (518) 485-1870; or electronically at the NYSDOL website www.labor.ny.gov.

Upon receiving the original schedule, the Department of Jurisdiction (Contracting Agency) is REQUIRED to provide complete copies to all prime contractors who in turn MUST, by law, provide copies of all applicable county schedules to each subcontractor and obtain from each subcontractor, an affidavit certifying such schedules were received. If the original schedule expired, the contractor may obtain a copy of the new annual determination from the NYSDOL website www.labor.ny.gov.

The Commissioner of Labor makes an annual determination of the prevailing rates. This determination is in effect from July 1st through June 30th of the following year. The annual determination is available on the NYSDOL website www.labor.ny.gov.

Payrolls and Payroll Records

Contractors and subcontractors are required to establish, maintain, and preserve for not less than six (6) years, contemporaneous, true, and accurate payroll records. Payrolls must show the following information for each person employed on a public work project: Name, Address, Last 4 Digits of Social Security Number, Classification(s) in which the worker was employed, Hourly wage rate(s) paid, Supplements paid or provided, and Daily and weekly number of hours worked in each classification.

The filing of payrolls to the Department of Jurisdiction is a condition of payment. Every contractor and subcontractor shall submit to the Department of Jurisdiction (Contracting Agency), within thirty (30) days after issuance of its first payroll and every thirty (30) days thereafter, a transcript of the original payrolls, subscribed and affirmed as true under penalty of perjury. The original payrolls or transcripts must be maintained for a period of at least (5) years, by the Department of Jurisdiction (Contracting Agency), from the project's date of completion. The Department of Jurisdiction (Contracting Agency) shall collect, review for facial validity, and maintain such payrolls.

In addition, the Commissioner of Labor may require contractors to furnish, with ten (10) days of a request, payroll records sworn to as their validity and accuracy for public work and private work. Payroll records include, but are not limited to time cards, work description sheets, proof that supplements were provided, cancelled payroll checks and payrolls. Failure to provide the requested information within the allotted ten (10) days will result in the withholding of up to 25% of the contract, not to exceed \$100,000.00. If the contractor or subcontractor does not maintain a place of business in New York State and the amount of the contract exceeds \$25,000.00, payroll records and certifications must be kept on the project worksite.

The prime contractor is responsible for any underpayments of prevailing wages or supplements by any subcontractor.

All contractors or their subcontractors shall provide to their subcontractors a copy of the Prevailing Rate Schedule specified in the public work contract as well as any subsequently issued schedules. A failure to provide these schedules by a contractor or subcontractor is a violation of Article 8, Section 220-a of the Labor Law.

All subcontractors engaged by a public work project contractor or its subcontractor, upon receipt of the original schedule and any subsequently issued schedules, shall provide to such contractor a verified statement attesting that the subcontractor has received the Prevailing Rate Schedule and will pay or provide the applicable rates of wages and supplements specified therein. (See NYS Labor Laws, Article 8 . Section 220-a).

Determination of Prevailing Wage and Supplement Rate Updates Applicable to All Counties

The wages and supplements contained in the annual determination become effective July 1st whether or not the new determination has been received by a given contractor. Care should be taken to review the rates for obvious errors. Any corrections should be brought to the Department's attention immediately. It is the responsibility of the public work contractor to use the proper rates. If there is a question on the proper classification to be used, please call the district office located nearest the project. Any errors in the annual determination will be corrected and posted to the NYSDOL website on the first business day of each month. Contractors are responsible for paying these updated rates as well, retroactive to July 1st.

When you review the schedule for a particular occupation, your attention should be directed to the dates above the column of rates. These are the dates for which a given set of rates is effective. To the extent possible, the Department posts rates in its possession that cover periods of time beyond the July 1st to June 30th time frame covered by a particular annual determination. Rates that extend beyond that instant time period are informational ONLY and may be updated in future annual determinations that actually cover the then appropriate July 1st to June 30th time period.

Withholding of Payments

When a complaint is filed with the Commissioner of Labor alleging the failure of a contractor or subcontractor to pay or provide the prevailing wages or supplements, or when the Commissioner of Labor believes that unpaid wages or supplements may be due, payments on the public work contract shall be withheld from the prime contractor in a sufficient amount to satisfy the alleged unpaid wages and supplements, including interest and civil penalty, pending a final determination.

When the Bureau of Public Work finds that a contractor or subcontractor on a public work project failed to pay or provide the requisite prevailing wages or supplements, the Bureau is authorized by Sections 220-b and 235.2 of the Labor Law to so notify the financial officer of the Department of Jurisdiction (Contracting Agency) that awarded the public work contract. Such officer MUST then withhold or cause to be withheld from any payment due the prime contractor on account of such contract the amount indicated by the Bureau as sufficient to satisfy the unpaid wages and supplements, including interest and any civil penalty that may be assessed by the Commissioner of Labor. The withholding continues until there is a final determination of the underpayment by the Commissioner of Labor or by the court in the event a legal proceeding is instituted for review of the determination of the Commissioner of Labor.

The Department of Jurisdiction (Contracting Agency) shall comply with this order of the Commissioner of Labor or of the court with respect to the release of the funds so withheld.

Summary of Notice Posting Requirements

The current Prevailing Rate Schedule must be posted in a prominent and accessible place on the site of the public work project. The prevailing wage schedule must be encased in, or constructed of, materials capable of withstanding adverse weather conditions and be titled "PREVAILING RATE OF WAGES" in letters no smaller than two (2) inches by two (2) inches.

The "[Public Work Project](#)" notice must be posted at the beginning of the performance of every public work contract, on each job site.

Every employer providing workers. compensation insurance and disability benefits must post notices of such coverage in the format prescribed by the Workers. Compensation Board in a conspicuous place on the jobsite.

Every employer subject to the NYS Human Rights Law must conspicuously post at its offices, places of employment, or employment training centers, notices furnished by the State Division of Human Rights.

Employers liable for contributions under the Unemployment Insurance Law must conspicuously post on the jobsite notices furnished by the NYS Department of Labor.

Apprentices

Employees cannot be paid apprentice rates unless they are individually registered in a program registered with the NYS Commissioner of Labor. The allowable ratio of apprentices to journeyworkers in any craft classification can be no greater than the statewide building trade ratios promulgated by the Department of Labor and included with the Prevailing Rate Schedule. An employee listed on a payroll as an apprentice who is not registered as above, must be paid the prevailing journeyworker's wage rate for the classification of work the employee is actually performing.

NYSDOL Labor Law, Article 8, Section 220-3, require that only apprentices individually registered with the NYS Department of Labor may be paid apprenticeship rates on a public work project. No other Federal or State Agency of office registers apprentices in New York State.

Persons wishing to verify the apprentice registration of any person must do so in writing by mail, to the NYSDOL Office of Employability Development / Apprenticeship Training, State Office Bldg. Campus, Bldg. 12, Albany, NY 12240 or by Fax to NYSDOL Apprenticeship Training (518) 457-7154. All requests for verification must include the name and social security number of the person for whom the information is requested.

The only conclusive proof of individual apprentice registration is written verification from the NYSDOL Apprenticeship Training Albany Central office. Neither Federal nor State Apprenticeship Training offices outside of Albany can provide conclusive registration information.

It should be noted that the existence of a registered apprenticeship program is not conclusive proof that any person is registered in that program. Furthermore, the existence or possession of wallet cards, identification cards, or copies of state forms is not conclusive proof of the registration of any person as an apprentice.

Interest and Penalties

In the event that an underpayment of wages and/or supplements is found:

- Interest shall be assessed at the rate then in effect as prescribed by the Superintendent of Banks pursuant to section 14-a of the Banking Law, per annum from the date of underpayment to the date restitution is made.
- A Civil Penalty may also be assessed, not to exceed 25% of the total of wages, supplements, and interest due.

Debarment

Any contractor or subcontractor and/or its successor shall be ineligible to submit a bid on or be awarded any public work contract or subcontract with any state, municipal corporation or public body for a period of five (5) years when:

- Two (2) willful determinations have been rendered against that contractor or subcontractor and/or its successor within any consecutive six (6) year period.
- There is any willful determination that involves the falsification of payroll records or the kickback of wages or supplements.

Criminal Sanctions

Willful violations of the Prevailing Wage Law (Article 8 of the Labor Law) may be a felony punishable by fine or imprisonment of up to 15 years, or both.

Discrimination

No employee or applicant for employment may be discriminated against on account of age, race, creed, color, national origin, sex, disability or marital status.

No contractor, subcontractor nor any person acting on its behalf, shall by reason of race, creed, color, disability, sex or national origin discriminate against any citizen of the State of New York who is qualified and available to perform the work to which the employment relates (NYS Labor Law, Article 8, Section 220-e(a)).

No contractor, subcontractor, nor any person acting on its behalf, shall in any manner, discriminate against or intimidate any employee on account of race, creed, color, disability, sex, or national origin (NYS Labor Law, Article 8, Section 220-e(b)).

The Human Rights Law also prohibits discrimination in employment because of age, marital status, or religion.

There may be deducted from the amount payable to the contractor under the contract a penalty of \$50.00 for each calendar day during which such person was discriminated against or intimidated in violation of the provision of the contract (NYS Labor Law, Article 8, Section 220-e(c)).

The contract may be cancelled or terminated by the State or municipality. All monies due or to become due thereunder may be forfeited for a second or any subsequent violation of the terms or conditions of the anti-discrimination sections of the contract (NYS Labor Law, Article 8, Section 220-e(d)).

Every employer subject to the New York State Human Rights Law must conspicuously post at its offices, places of employment, or employment training centers notices furnished by the State Division of Human Rights.

Workers' Compensation

In accordance with Section 142 of the State Finance Law, the contractor shall maintain coverage during the life of the contract for the benefit of such employees as required by the provisions of the New York State Workers' Compensation Law.

A contractor who is awarded a public work contract must provide proof of workers' compensation coverage prior to being allowed to begin work.

The insurance policy must be issued by a company authorized to provide workers' compensation coverage in New York State. Proof of coverage must be on form C-105.2 (Certificate of Workers' Compensation Insurance) and must name this agency as a certificate holder.

If New York State coverage is added to an existing out-of-state policy, it can only be added to a policy from a company authorized to write workers' compensation coverage in this state. The coverage must be listed under item 3A of the information page.

The contractor must maintain proof that subcontractors doing work covered under this contract secured and maintained a workers' compensation policy for all employees working in New York State.

Every employer providing worker's compensation insurance and disability benefits must post notices of such coverage in the format prescribed by the Workers' Compensation Board in a conspicuous place on the jobsite.

Unemployment Insurance

Employers liable for contributions under the Unemployment Insurance Law must conspicuously post on the jobsite notices furnished by the New York State Department of Labor.



Andrew M. Cuomo, Governor

Roberta Reardon, Commissioner

Essex County DPW
Lucas Short, Assistant Project Engineer
Creighton Manning LLP
2 Winners Circle
Albany NY 12205

Schedule Year 2018 through 2019
Date Requested 01/22/2019
PRC# 2019000892

Location .6 miles N of State Route 28N
Project ID# PIN 1760.68
Project Type Campsite Road over the Hudson River Bridge Replacement in the Town of Newcomb, Essex County, New York.

Notice of Contract Award

New York State Labor Law, Article 8, Section 220.3a requires that certain information regarding the awarding of public work contracts, be furnished to the Commissioner of Labor. One "Notice of Contract Award" (PW 16, which may be photocopied), **MUST** be completed for **EACH** prime contractor on the above referenced project.

Upon notifying the successful bidder(s) of this contract, enter the required information and mail **OR** fax this form to the office shown at the bottom of this notice, **OR** fill out the electronic version via the NYSDOL website.

Contractor Information

All information must be supplied

Federal Employer Identification Number: _____		
Name: _____		
Address: _____ _____		
City: _____	State: _____	Zip: _____
Amount of Contract: \$ _____	Contract Type:	
Approximate Starting Date: ____/____/____	<input type="checkbox"/> (01) General Construction	
Approximate Completion Date: ____/____/____	<input type="checkbox"/> (02) Heating/Ventilation	
	<input type="checkbox"/> (03) Electrical	
	<input type="checkbox"/> (04) Plumbing	
	<input type="checkbox"/> (05) Other : _____	

Phone: (518) 457-5589 Fax: (518) 485-1870
W. Averell Harriman State Office Campus, Bldg. 12, Room 130, Albany, NY 12240

IMPORTANT NOTICE

FOR

CONTRACTORS & CONTRACTING AGENCIES

Social Security Numbers on Certified Payrolls

The Department of Labor is cognizant of the concerns of the potential for misuse or inadvertent disclosure of social security numbers. Identity theft is a growing problem and we are sympathetic to contractors' concerns with regard to inclusion of this information on payrolls if another identifier will suffice.

For these reasons, *the substitution of the use of the last four digits of the social security number on certified payrolls submitted to contracting agencies on public work projects is now acceptable to the Department of Labor.*

NOTE: This change does not affect the Department's ability to request and receive the entire social security number from employers during the course of its public work / prevailing wage investigations.

Construction Industry Fair Play Act

Required Posting For Labor Law Article 25-B § 861-d

Construction industry employers must post the "Construction Industry Fair Play Act" notice in a prominent and accessible place on the job site.

Failure to post the notice can result in penalties of up to \$1,500 for a first offense and up to \$5,000 for a second offense.

The posting is included as part of this wage schedule. Additional copies may be obtained from the NYS DOL website, www.labor.ny.gov.

If you have any questions concerning the Fair Play Act, please call the State Labor Department toll-free at 1-866-435-1499 or email us at: dol.misclassified@labor.state.ny.us .



New York State Department of Labor
Required Notice under Article 25-B of the Labor Law

**ATTENTION ALL EMPLOYEES, CONTRACTORS AND SUBCONTRACTORS:
YOU ARE COVERED BY THE
CONSTRUCTION INDUSTRY FAIR PLAY ACT**

The law says that you are an employee unless:

- You are free from direction and control in performing your job AND
- You perform work that is not part of the usual work done by the business that hired you AND
- You have an independently established business

Your employer cannot consider you to be an independent contractor unless all three of these facts apply to your work.

**IT IS AGAINST THE LAW FOR AN EMPLOYER TO MISCLASSIFY EMPLOYEES AS
INDEPENDENT CONTRACTORS OR PAY EMPLOYEES OFF-THE-BOOKS.**

Employee rights. If you are an employee:

- You are entitled to state and federal worker protections such as
 - unemployment benefits, if unemployed through no fault of your own, able to work, and otherwise qualified
 - workers' compensation benefits for on-the-job injuries
 - payment for wages earned, minimum wage, and overtime (under certain conditions)
 - prevailing wages on public work projects
 - the provisions of the National Labor Relations Act and
 - a safe work environment
- It is a violation of this law for employers to retaliate against anyone who asserts their rights under the law. Retaliation subjects an employer to civil penalties, a private lawsuit or both.

Independent Contractors: If you are an independent contractor:

- You must pay all taxes required by New York State and Federal Law.

Penalties for paying off-the-books or improperly treating employees as independent contractors:

- **Civil Penalty** First Offense: up to \$2,500 per employee.
 Subsequent Offense(s): up to \$5,000 per employee.
- **Criminal Penalty** First Offense: Misdemeanor - up to 30 days in jail, up to a \$25,000 fine and debarment from performing Public Work for up to one year.
 Subsequent Offense(s): Misdemeanor - up to 60 days in jail, up to a \$50,000 fine and debarment from performing Public Work for up to 5 years.

If you have questions about your employment status or believe that your employer may have violated your rights and you want to file a complaint, call the Department of Labor at 1(866)435-1499 or send an email to dol.misclassified@labor.state.ny.us. All complaints of fraud and violations are taken seriously and you can remain anonymous.

Employer Name:

WORKER NOTIFICATION

(Labor Law §220, paragraph a of subdivision 3-a)

Effective February 24, 2008

This provision is an addition to the existing prevailing wage rate law, Labor Law §220, paragraph a of subdivision 3-a. It requires contractors and subcontractors to provide written notice to all laborers, workers or mechanics of the *prevailing wage rate* for their particular job classification *on each pay stub**. It also requires contractors and subcontractors to *post a notice* at the beginning of the performance of every public work contract *on each job site* that includes the telephone number and address for the Department of Labor and a statement informing laborers, workers or mechanics of their right to contact the Department of Labor if he/she is not receiving the proper prevailing rate of wages and/or supplements for his/her particular job classification. The required notification will be provided with each wage schedule, may be downloaded from our website www.labor.state.ny.us or made available upon request by contacting the Bureau of Public Work at 518-457-5589.

* In the event that the required information will not fit on the pay stub, an accompanying sheet or attachment of the information will suffice.

Attention Employees

THIS IS A: PUBLIC WORK PROJECT

If you are employed on this project as a **worker, laborer, or mechanic** you are entitled to receive the **prevailing wage and supplements rate** for the classification at which you are working.

Chapter 629 of the Labor Laws of 2007:

These wages are set by law and must be posted at the work site. They can also be found at:
www.labor.ny.gov

If you feel that you have not received proper wages or benefits, please call our nearest office.*

Albany	(518) 457-2744	Patchogue	(631) 687-4882
Binghamton	(607) 721-8005	Rochester	(585) 258-4505
Buffalo	(716) 847-7159	Syracuse	(315) 428-4056
Garden City	(516) 228-3915	Utica	(315) 793-2314
New York City	(212) 932-2419	White Plains	(914) 997-9507
Newburgh	(845) 568-5156		

* For New York City government agency construction projects, please contact the Office of the NYC Comptroller at (212) 669-4443, or www.comptroller.nyc.gov – click on Bureau of Labor Law.

Contractor Name: _____

Project Location: _____

OSHA 10-hour Construction Safety and Health Course – S1537-A

Effective July 18, 2008

This provision is an addition to the existing prevailing wage rate law, Labor Law §220, section 220-h. It requires that on all public work projects of at least \$250,000.00, all laborers, workers and mechanics working on the site, be certified as having successfully completed the OSHA 10-hour construction safety and health course. It further requires that the advertised bids and contracts for every public work contract of at least \$250,000.00, contain a provision of this requirement.

NOTE: The OSHA 10 Legislation only applies to workers on a public work project that are required, under Article 8, to receive the prevailing wage.

Where to find OSHA 10-hour Construction Course

1. NYS Department of Labor website for scheduled outreach training at:

www.labor.state.ny.us/workerprotection/safetyhealth/DOSH_ONSITE_CONSULTATION.shtm

2. OSHA Training Institute Education Centers:

Rochester Institute of Technology OSHA Education Center

Rochester, NY

Donna Winter

Fax (585) 475-6292

e-mail: dlwtpo@rit.edu

(866) 385-7470 Ext. 2919

www.rit.edu/~outreach/course.php3?CourseID=54

Atlantic OSHA Training Center

UMDNJ – School of Public Health

Piscataway, NJ

Janet Crooks

Fax (732) 235-9460

e-mail: crooksje@umdnj.edu

(732) 235-9455

<https://ophp.umdnj.edu/wconnect/ShowSchedule.awp?~~GROUP~AOTCON~10~>

Atlantic OSHA Training Center

University at Buffalo

Buffalo, New York

Joe Syracuse

Fax (716) 829-2806

e-mail: mailto:japs@buffalo.edu

(716) 829-2125

http://www.smbs.buffalo.edu/CENTERS/trc/schedule_OSHA.php

Keene State College

Manchester, NH

Leslie Singleton

e-mail: lsingletin@keene.edu

(800) 449-6742

www.keene.edu/courses/print/courses_osh.cfm

3. List of trainers and training schedules for OSHA outreach training at:

www.OutreachTrainers.org

Requirements for OSHA 10 Compliance

Chapter 282 of the Laws of 2007, codified as Labor Law 220-h took effect on July 18, 2008. The statute provides as follows:

The advertised specifications for every contract for public work of \$250,000.00 or more must contain a provision requiring that every worker employed in the performance of a public work contract shall be certified as having completed an OSHA 10 safety training course. The clear intent of this provision is to require that all employees of public work contractors, required to be paid prevailing rates, receive such training “prior to the performing any work on the project.”

The Bureau will enforce the statute as follows:

All contractors and sub contractors must attach a copy of proof of completion of the OSHA 10 course to the first certified payroll submitted to the contracting agency and on each succeeding payroll where any new or additional employee is first listed.

Proof of completion may include but is not limited to:

- Copies of bona fide course completion card (*Note: Completion cards do not have an expiration date.*)
- Training roster, attendance record of other documentation from the certified trainer pending the issuance of the card.
- Other valid proof

**A certification by the employer attesting that all employees have completed such a course is not sufficient proof that the course has been completed.

Any questions regarding this statute may be directed to the New York State Department of Labor, Bureau of Public Work at 518-485-5696.

WICKS Reform 2008

(For all contracts advertised or solicited for bid on or after 7/1/08)

- Raises the threshold for public work projects subject to the Wicks Law requiring separate specifications and bidding for the plumbing, heating and electrical work. The total project's threshold would increase from \$50,000 to: \$3 million in Bronx, Kings, New York, Queens and Richmond counties; \$1.5 million in Nassau, Suffolk and Westchester counties; and \$500,000 in all other counties.
- For projects below the monetary threshold, bidders must submit a sealed list naming each subcontractor for the plumbing, HVAC and electrical work and the amount to be paid to each. The list may not be changed unless the public owner finds a legitimate construction need, including a change in specifications or costs or use of a Project Labor Agreement (PLA), and must be open to public inspection.
- Allows the state and local agencies and authorities to waive the Wicks Law and use a PLA if it will provide the best work at the lowest possible price. If a PLA is used, all contractors shall participate in apprentice training programs in the trades of work it employs that have been approved by the Department of Labor (DOL) for not less than three years. They shall also have at least one graduate in the last three years and use affirmative efforts to retain minority apprentices. PLA's would be exempt from Wicks, but deemed to be public work subject to prevailing wage enforcement.
- The Commissioner of Labor shall have the power to enforce separate specification requirements on projects, and may issue stop-bid orders against public owners for non-compliance.
- Other new monetary thresholds, and similar sealed bidding for non-Wicks projects, would apply to certain public authorities including municipal housing authorities, NYC Construction Fund, Yonkers Educational Construction Fund, NYC Municipal Water Finance Authority, Buffalo Municipal Water Finance Authority, Westchester County Health Care Association, Nassau County Health Care Corp., Clifton-Fine Health Care Corp., Erie County Medical Center Corp., NYC Solid Waste Management Facilities, and the Dormitory Authority.
- Reduces from 15 to 7 days the period in which contractors must pay subcontractors.

IMPORTANT INFORMATION

**Regarding Use of Form PW30.1
(Previously 30R)**

“Employer Registration for Use of 4 Day / 10 Hour Work Schedule”

To use the ‘4 Day / 10 Hour Work Schedule’:

There **MUST** be a *Dispensation of Hours (PW30)* in place on the project

AND

You **MUST** register your intent to work 4 / 10 hour days, by completing the PW30.1 Form.

REMEMBER...

The ‘4 Day / 10 Hour Work Schedule’ applies **ONLY** to Job Classifications and Counties listed on the PW30.1 Form.

Do not write in any additional Classifications or Counties.

(Please note : For each Job Classification check the individual wage schedule for specific details regarding their 4/10 hour day posting.)

Instructions for Completing Form PW30.1

(Previously 30R)

“Employer Registration for Use of 4 Day / 10 Hour Work Schedule”

Before completing Form PW30.1 check to be sure ...

- There is a *Dispensation of Hours* in place on the project.
- The 4 Day / 10 Hour Work Schedule applies to the Job Classifications you will be using.
- The 4 Day / 10 Hour Work Schedule applies to the County / Counties where the work will take place.

Instructions (Type or Print legibly):

Contractor Information:

- Enter the Legal Name of the business, FEIN, Street Address, City, State, Zip Code; the Company’s Phone and Fax numbers; and the Company’s email address (if applicable)
- Enter the Name of a Contact Person for the Company along with their Phone and Fax numbers, and the personal email address (if applicable)

Project Information:

- Enter the Prevailing Rate Case number (PRC#) assigned to this project
- Enter the Project Name / Type (i.e. Smithtown CSD – Replacement of HS Roof)
- Enter the Exact Location of Project (i.e. Smithtown HS, 143 County Route #2, Smithtown,NY; Bldgs. 1 & 2)
- If you are a Subcontractor, enter the name of the Prime Contractor for which you work
- On the Checklist of Job Classifications -
 - Go to pages 2 and 3 of the form
 - Place a checkmark in the box to the right of the Job Classification you are choosing
 - Mark all Job Classifications that apply

Do not write in any additional Classifications or Counties.

Requestor Information:

- Enter the name of the person submitting the registration, their title with the company , and the date the registration is filled out

Return Completed Form:

- **Mail** the completed PW30.1 form to: NYSDOL Bureau of Public Work, SOBC – Bldg.12 – Rm.130, Albany, NY 12240 **-OR-**
- **Fax** the completed PW30.1 form to: NYSDOL Bureau of Public Work at (518)485-1870



Bureau of Public Work Harriman
State Office Campus
Building 12, Room 130
Albany, New York 12240
Phone: (518) 457-5589 | Fax: (518) 485-1870
www.labor.ny.gov

Employer Registration for Use of 4 Day / 10 Hour Work Schedule

Before completing this form, make sure that:

- There is a **Dispensation of Hours** in place on the project.
- The 4 Day / 10 Hour Work Schedule applies to the Job Classifications you will be using.
- The 4 Day / 10 Hour Work Schedule applies to the County / Counties where the work will take place.

Please **type or print** the requested information and then **mail or fax** to the address above.

Contractor Information

Company Name: _____ FEIN: _____

Address: _____

City: _____ State: _____ Zip Code: _____

Phone No: _____ Fax No: _____ Email: _____

Contact Person: _____

Phone No: _____ Fax No: _____ Email: _____

Project Information

Project PRC#: _____ Project Name/Type: _____

Exact Location
of Project: _____ County: _____

(If you are Subcontractor)

Prime Contractor Name: _____

Job Classification(s) to Work 4/10 Schedule: *(Choose all that apply on Job Classification Checklist - Pages 3-8)*
**** Do not write in any additional Classifications or Counties****

Requestor Information

Name: _____

Title: _____ Date: _____

Please use the list below with the number assigned to each county as a reference to the corresponding numbers listed in the following pages under **Entire Counties & Partial Counties**.

- | | | | |
|-----|-----------------------------|-----|---------------------------------|
| 1. | Albany County | 33. | Oneida County |
| 2. | Allegany County | 34. | Onondaga County |
| 3. | Bronx County | 35. | Ontario County |
| 4. | Broome County | 36. | Orange County |
| 5. | Cattaraugus County | 37. | Orleans County |
| 6. | Cayuga County | 38. | Oswego County |
| 7. | Chautauqua County | 39. | Otsego County |
| 8. | Chemung County | 40. | Putnam County |
| 9. | Chenango County | 41. | Queens County |
| 10. | Clinton County | 42. | Rensselaer County |
| 11. | Columbia County | 43. | Richmond County (Staten Island) |
| 12. | Cortland County | 44. | Rockland County |
| 13. | Delaware County | 45. | Saint Lawrence County |
| 14. | Dutchess County | 46. | Saratoga County |
| 15. | Erie County | 47. | Schenectady County |
| 16. | Essex County | 48. | Schoharie County |
| 17. | Franklin County | 49. | Schuyler County |
| 18. | Fulton County | 50. | Seneca County |
| 19. | Genesee County | 51. | Steuben County |
| 20. | Greene County | 52. | Suffolk County |
| 21. | Hamilton County | 53. | Sullivan County |
| 22. | Herkimer County | 54. | Tioga County |
| 23. | Jefferson County | 55. | Tompkins County |
| 24. | Kings County (Brooklyn) | 56. | Ulster County |
| 25. | Lewis County | 57. | Warren County |
| 26. | Livingston County | 58. | Washington County |
| 27. | Madison County | 59. | Wayne County |
| 28. | Monroe County | 60. | Westchester County |
| 29. | Montgomery County | 61. | Wyoming County |
| 30. | Nassau County | 62. | Yates County |
| 31. | New York County (Manhattan) | | |
| 32. | Niagara County | | |

Job Classification Checklist

(Place a checkmark by all classifications that will be using the 4/10 schedule)

**** Do not write in any additional Classifications or Counties****

Job Classification	Tag #	Entire Counties	Partial Counties	Check Box
Carpenter – Building	276B-All	7	2 ,5	
Carpenter – Building	276B-Cat	15	5	
Carpenter – Building	276-B-LIV	26, 28, 35, 59	61	
Carpenter – Building	276B-Gen	19, 32, 37	61	
Carpenter – Heavy & Highway	276HH-All	2, 5, 7		
Carpenter – Heavy & Highway	276HH-Erie	15		
Carpenter – Heavy & Highway	276HH- Gen	19, 32, 37, 61		
Carpenter – Heavy & Highway	276HH-Liv	26, 28, 35, 59		
Carpenter – Residential	276R-All	7	2, 5	
Carpenter – Building	277B-Bro	4, 54		
Carpenter – Building	277B-CAY	6, 50, 62		
Carpenter – Building	277B-CS	8, 12, 49, 51, 55	2	
Carpenter – Building	277 JLS	23, 25, 45		
Carpenter – Building	277 omh	22, 27, 33		
Carpenter – Building	277 On	34		
Carpenter – Building	277 Os	38		
Carpenter – Building	277CDO Bldg	9, 13, 39		
Carpenter – Heavy & Highway	277CDO HH	9, 13, 39		
Carpenter – Heavy & Highway	277HH-BRO	4, 6, 8, 12, ,22, 23, 25, 27, 33, 34, 38, 45, 49, 50, 51, 54, 55, 62		
Carpenter – Building	291B-Alb	1, 18, 20, 29, 42, 47, 48		
Carpenter – Building	291B-Cli	10, 16, 17		
Carpenter – Building	291B-Ham	21, 57, 58		
Carpenter – Building	291B-Sar	46		
Carpenter – Heavy & Highway	291HH-Alb	1, 10, 16, 17,18, 20, 21, 29, 42, 46, 47, 48, 57, 58		
Electrician	25m	30, 52		
Electrician – Teledata Cable Splicer	43	12, 22, 27, 33, 38	6, 9, 34, 39, 55, 59	

Job Classification Checklist

(Place a checkmark by all classifications that will be using the 4/10 schedule)

**** Do not write in any additional Classifications or Counties****

Job Classification	Tag #	Entire Counties	Partial Counties	Check Box
Electrician	86	26, 28	19, 35, 37, 59, 61	
Electrician	840 Teledata and 840 Z1	62	6, 34, 35, 50, 59	
Electrician	910	10, 16, 17, 23, 25, 45		
Electrical Lineman	1049Line/Gas	30, 41, 52		
Electrical Lineman	1249a	1, 2, 4, 5, 6, 7, 8, 9, 10, 11, 12, 13, 14, 15, 16, 17, 18, 19, 20, 21, 22, 23, 25, 26, 27, 28, 29, 32, 33, 34, 35, 36, 37, 38, 39, 40, 42, 44, 46, 47, 48, 49, 50, 45, 51, 53, 54, 55, 56, 57, 58, 59, 61, 62		
Electrical Lineman	1249a West	60		
Electrical Lineman	1249a-LT	1, 2, 4, 5, 6, 7, 8, 9, 10, 12, 13, 15, 16, 17, 18, 19, 20, 21, 22, 23, 25, 26, 27, 28, 29, 32, 33, 34, 35, 37, 38, 39, 42, 46, 47, 48, 49, 50, 45, 51, 53, 54, 55, 57, 58, 59, 61, 62		
Electrical Lineman	1249aREG8LT	11, 14, 36, 40, 44, 56		
Electrical Lineman	1249aWestLT	60		
Elevator Constructor	138	11, 14, 20, 36, 40, 53, 56	13, 44, 60	
Elevator Constructor	14	2, 5, 7, 15, 19, 32, 37, 61		
Elevator Constructor	27	8, 26, 28, 35, 49, 50, 51, 59, 62		
Elevator Constructor	35	1, 10, 16, 18, 21, 22, 29, 39, 42, 46, 47, 48, 57, 58		
Elevator Constructor	62.1	4, 6, 9, 12, 23, 25, 27, 33, 34, 38, 45, 54, 55	13	
Glazier	201	1, 10, 11, 16, 17, 18, 20, 21, 29, 42, 46, 47, 48, 57, 58		
Glazier	660r	2, 5, 7, 15, 19, 32, 37, 61		
Glazier	660	2, 5, 7, 15, 19, 32, 37, 61		
Glazier	677.1	23, 25, 26, 28, 35, 45, 50, 59, 62		
Glazier	677Z-2	6, 12, 22, 27, 33, 34, 38		
Glazier	677z3	4, 8, 9, 13, 39, 49, 51, 54, 55		
Glazier	677r.2	6, 12, 22, 27, 33, 34, 38		
Insulator – Heat & Frost	30-Syracuse	4, 6, 8, 9, 12, 22, 23, 25, 27, 33, 34, 38, 39, 49, 50, 45, 54, 55		
Laborer – Building	621b	2, 7	5	
Laborer – Building	633 bON	34		

Job Classification Checklist

(Place a checkmark by all classifications that will be using the 4/10 schedule)

*** Do not write in any additional Classifications or Counties***

Job Classification	Tag #	Entire Counties	Partial Counties	Check Box
Laborer – Building	633b Cay	6		
Laborer – Building	633bOS	38		
Laborer – Building	785(7)	4	9, 13, 54	
Laborer – Building	785B-CS	8, 51	49	
Laborer – Building	7-785b	12, 55	49, 54	
Laborers – Heavy & Highway	157h/h	47	18, 29, 46	
Laborers – Heavy & Highway	190 h/h	1, 42, 58	11, 20, 46	
Laborers – Heavy & Highway	35/2h	21, 22, 27, 33	18, 29	
Laborer – Residential	621r	2, 7	5	
Laborers – Tunnel	157	47	18, 29, 46	
Laborers – Tunnel	35T	21, 22, 27, 33	18, 29	
Laborers – Tunnel	190	1, 42, 58	11, 20, 46	
Mason – Building	2TS.1	1, 10, 11, 16, 17, 18, 20, 21, 29, 42, 46, 47, 48, 57, 58		
Mason – Building	2TS.2	22, 23, 25, 33, 45	27	
Mason – Building	2TS.3	6, 34, 38	27	
Mason – Building	2b-on	34		
Mason – Building	2b.1	1, 11, 18, 20, 21, 29, 42, 46, 47, 48, 58	57	
Mason – Building	2b.2	22, 33	25	
Mason – Building	2b.3	6, 34	27	
Mason – Building	2b.4	38		
Mason – Building	2b.5	23	25	
Mason – Building	2b.6	45		
Mason – Building	2b.8	10, 16, 17	57	
Mason – Building	3b-Co-Z2	8, 49, 51	2	
Mason – Building	3B-Z1	19, 26, 28, 35, 50, 59, 61, 62		
Mason – Building – Residential	3B-Z1R	19, 26, 28, 35, 50, 59, 61, 62		
Mason – Building	3B-Bing-Z2	4, 9, 13, 39, 54		
Mason – Building	3B-lth-Z2	12, 55		

Job Classification Checklist

(Place a checkmark by all classifications that will be using the 4/10 schedule)

*** Do not write in any additional Classifications or Counties***

Job Classification	Tag #	Entire Counties	Partial Counties	Check Box
Mason – Building	3B-Jam-Z2	7	2, 5	
Mason – Building – Residential	3B-Jam-Z2R	2, 4, 8, 7, 9, 12, 39, 13, 49, 51, 54, 55	5	
Mason – Building	3B-Z3	15, 32	5	
Mason – Building	3B-Z3.Orleans	37		
Mason – Residential	3B-Z3R	15, 32	5	
Mason – Residential	3B-z3R.Orleans	37		
Mason - Heavy & Highway	3h	2, 4, 8, 7, 9, 12, 13, 19, 26, 28, 35, 37, 39, 49, 50, 51, 54, 55, 59, 61, 62	5, 15, 32	
Mason – Tile Finisher	3TF-Z1	19, 26, 28, 35, 50, 59, 61, 62		
Mason – Tile Finisher	3TF-Z2	2, 4, 8, 7, 9, 12, 13, 39, 49, 51, 54, 55	5	
Mason – Tile Finisher	3TF-Z3	15, 32, 37	5	
Mason – Tile Finisher	3TF-Z1R	19, 26, 28, 35, 50, 59, 61, 62		
Mason – Tile Finisher	3TF-Z2R	2, 4, 7, 9, 12, 13, 39, 49, 51, 54, 55	5	
Mason – Tile Finisher	3TF-Z3R	15, 32, 37	5	
Mason – Tile Setter	3TS-Z1	19, 26, 28, 35, 50, 59, 61, 62		
Mason – Tile Setter Residential	3TS-Z1R	19, 26, 28, 35, 50, 59, 61, 62		
Mason – Tile Setter	3TS-Z2	2, 4, 7, 8, 9, 12, 13, 39, 49, 51, 54, 55	5	
Mason – Tile Setter Residential	3TS-Z2R	2, 4, 7, 8, 9, 12, 13, 39, 49, 51, 54, 55	5	
Mason – Tile Setter	3TS-Z3	15, 32, 37	5	
Mason – Tile Setter Residential	3TS-Z3R	15, 32, 37	5	
Mason – Building/Heavy & Highway	780	3, 24, 30, 31, 41, 43, 52		
Operating Engineer - Heavy & Highway	137H/H	40, 60	14	
Operating Engineer – Heavy & Highway	158-832H	2, 8, 26, 28, 35, 49, 51, 59, 62	19	
Operating Engineer – Heavy & Highway	158-H/H	1, 4, 9, 10, 11, 14, 16, 17, 18, 20, 21, 22, 29, 39, 42, 46, 47, 48, 54, 57, 58		
Operating Engineer – Heavy & Highway	158-545h	6, 12, 23, 25, 27, 33, 38, 45, 50, 55		
Painter	1456-LS	1, 3, 10, 11, 14, 16, 17, 18, 20, 21, 24, 29, 30, 31, 36, 40, 41, 42, 43, 44, 46, 47, 48, 52, 53, 56, 57, 58, 60		
Painter	150	28, 59, 62	26, 35	

Job Classification Checklist

(Place a checkmark by all classifications that will be using the 4/10 schedule)

**** Do not write in any additional Classifications or Counties****

Job Classification	Tag #	Entire Counties	Partial Counties	Check Box
Painter	178 B	4, 9, 54		
Painter	178 E	8, 49	51	
Painter	178 I	12, 55		
Painter	178 O	13, 39		
Painter	31	6, 22, 27, 33, 34, 50	25, 35, 38	
Painter	38.O		38	
Painter	38.W	23, 45	25	
Painter	4- Buf,Nia,Olean	2, 15, 19, 32, 37, 61	5, 7, 26, 51	
Painter	4-Jamestown		5, 7	
Sheetmetal Worker	46	26, 28, 35, 50, 59, 62		
Sheetmetal Worker	46r	26, 28, 35, 50, 59, 62		
Teamsters – Heavy & Highway	294h/h	1, 11, 18, 20, 29, 42, 46, 47, 48, 58	57	
Teamsters – Heavy & Highway	317bhh	6, 12, 50, 51, 55, 62	2	
Teamsters - Building/Heavy & Highway	456	40, 60		

Introduction to the Prevailing Rate Schedule

Information About Prevailing Rate Schedule

This information is provided to assist you in the interpretation of particular requirements for each classification of worker contained in the attached Schedule of Prevailing Rates.

Classification

It is the duty of the Commissioner of Labor to make the proper classification of workers taking into account whether the work is heavy and highway, building, sewer and water, tunnel work, or residential, and to make a determination of wages and supplements to be paid or provided. It is the responsibility of the public work contractor to use the proper rate. If there is a question on the proper classification to be used, please call the district office located nearest the project. District office locations and phone numbers are listed below.

Prevailing Wage Schedules are issued separately for "General Construction Projects" and "Residential Construction Projects" on a county-by-county basis.

General Construction Rates apply to projects such as: Buildings, Heavy & Highway, and Tunnel and Water & Sewer rates.

Residential Construction Rates generally apply to construction, reconstruction, repair, alteration, or demolition of one family, two family, row housing, or rental type units intended for residential use.

Some rates listed in the Residential Construction Rate Schedule have a very limited applicability listed along with the rate. Rates for occupations or locations not shown on the residential schedule must be obtained from the General Construction Rate Schedule. Please contact the local Bureau of Public Work office before using Residential Rate Schedules, to ensure that the project meets the required criteria.

Payrolls and Payroll Records

Contractors and subcontractors are required to establish, maintain, and preserve for not less than six (6) years, contemporaneous, true, and accurate payroll records.

Every contractor and subcontractor shall submit to the Department of Jurisdiction (Contracting Agency), within thirty (30) days after issuance of its first payroll and every thirty (30) days thereafter, a transcript of the original payrolls, subscribed and affirmed as true under penalty of perjury.

Paid Holidays

Paid Holidays are days for which an eligible employee receives a regular day's pay, but is not required to perform work. If an employee works on a day listed as a paid holiday, this remuneration is in addition to payment of the required prevailing rate for the work actually performed.

Overtime

At a minimum, all work performed on a public work project in excess of eight hours in any one day or more than five days in any workweek is overtime. However, the specific overtime requirements for each trade or occupation on a public work project may differ. Specific overtime requirements for each trade or occupation are contained in the prevailing rate schedules.

Overtime holiday pay is the premium pay that is required for work performed on specified holidays. It is only required where the employee actually performs work on such holidays.

The applicable holidays are listed under HOLIDAYS: OVERTIME. The required rate of pay for these covered holidays can be found in the OVERTIME PAY section listings for each classification.

Supplemental Benefits

Particular attention should be given to the supplemental benefit requirements. Although in most cases the payment or provision of supplements is straight time for all hours worked, some classifications require the payment or provision of supplements, or a portion of the supplements, to be paid or provided at a premium rate for premium hours worked. Supplements may also be required to be paid or provided on paid holidays, regardless of whether the day is worked. The Overtime Codes and Notes listed on the particular wage classification will indicate these conditions as required.

Effective Dates

When you review the schedule for a particular occupation, your attention should be directed to the dates above the column of rates. These are the dates for which a given set of rates is effective. The rate listed is valid until the next effective rate change or until the new annual determination which takes effect on July 1 of each year. All contractors and subcontractors are required to pay the current prevailing rates of wages and supplements. If you have any questions please contact the Bureau of Public Work or visit the New York State Department of Labor website (www.labor.state.ny.us) for current wage rate information.

Apprentice Training Ratios

The following are the allowable ratios of registered Apprentices to Journey-workers.

For example, the ratio 1:1,1:3 indicates the allowable initial ratio is one Apprentice to one Journeyworker. The Journeyworker must be in place on the project before an Apprentice is allowed. Then three additional Journeyworkers are needed before a second Apprentice is allowed. The last ratio repeats indefinitely. Therefore, three more Journeyworkers must be present before a third Apprentice can be hired, and so on.

Please call Apprentice Training Central Office at (518) 457-6820 if you have any questions.

Title (Trade)	Ratio
Boilermaker (Construction)	1:1,1:4
Boilermaker (Shop)	1:1,1:3
Carpenter (Bldg.,H&H, Pile Driver/Dockbuilder)	1:1,1:4
Carpenter (Residential)	1:1,1:3
Electrical (Outside) Lineman	1:1,1:2
Electrician (Inside)	1:1,1:3
Elevator/Escalator Construction & Modernizer	1:1,1:2
Glazier	1:1,1:3
Insulation & Asbestos Worker	1:1,1:3
Iron Worker	1:1,1:4
Laborer	1:1,1:3
Mason	1:1,1:4
Millwright	1:1,1:4
Op Engineer	1:1,1:5
Painter	1:1,1:3
Plumber & Steamfitter	1:1,1:3
Roofer	1:1,1:2
Sheet Metal Worker	1:1,1:3
Sprinkler Fitter	1:1,1:2

If you have any questions concerning the attached schedule or would like additional information, please contact the nearest BUREAU of PUBLIC WORK District Office or write to:

New York State Department of Labor
Bureau of Public Work
State Office Campus, Bldg. 12
Albany, NY 12240

District Office Locations:	Telephone #	FAX #
Bureau of Public Work - Albany	518-457-2744	518-485-0240
Bureau of Public Work - Binghamton	607-721-8005	607-721-8004
Bureau of Public Work - Buffalo	716-847-7159	716-847-7650
Bureau of Public Work - Garden City	516-228-3915	516-794-3518
Bureau of Public Work - Newburgh	845-568-5287	845-568-5332
Bureau of Public Work - New York City	212-932-2419	212-775-3579
Bureau of Public Work - Patchogue	631-687-4882	631-687-4902
Bureau of Public Work - Rochester	585-258-4505	585-258-4708
Bureau of Public Work - Syracuse	315-428-4056	315-428-4671
Bureau of Public Work - Utica	315-793-2314	315-793-2514
Bureau of Public Work - White Plains	914-997-9507	914-997-9523
Bureau of Public Work - Central Office	518-457-5589	518-485-1870

Essex County General Construction

Boilermaker **01/01/2019**

JOB DESCRIPTION Boilermaker **DISTRICT 1**

ENTIRE COUNTIES

Albany, Broome, Chenango, Columbia, Delaware, Essex, Fulton, Greene, Hamilton, Herkimer, Montgomery, Otsego, Rensselaer, Saratoga, Schenectady, Schoharie, Tioga, Warren, Washington

WAGES

Per hour	07/01/2018	01/01/2019	01/01/2020
Boilermaker	\$ 35.99	\$ 37.29	+1.59

SUPPLEMENTAL BENEFITS

Per hour	07/01/2018	01/01/2019
Journeyman	\$ 24.25 + 1.24*	\$ 24.53 + 1.24*

* This portion of the benefit is NOT subject to the SAME PREMIUM as shown for overtime.

OVERTIME PAY

See (B, E, Q, V) on OVERTIME PAGE

HOLIDAY

Paid: See (1) on HOLIDAY PAGE
 Overtime: See (5, 6, 15, 25) on HOLIDAY PAGE

Note: When a holiday falls on Sunday, the day observed by the State or Nation shall be observed, and when Christmas Day and New Year's fall on Saturday, Friday will be observed as the holiday.

REGISTERED APPRENTICES

Wages per hour
 (1/2) year terms at the following percentage of Journeyman's wage.

1st	2nd	3rd	4th	5th	6th	7th	8th
65%	65%	70%	75%	80%	85%	90%	95%

Supplemental Benefits per hour

07/01/2018

1st	2nd	3rd	4th	5th	6th	7th	8th
18.24	18.24	19.11	19.97	20.82	21.67	22.54	23.40
+1.24*	+1.24*	+1.24*	+1.24*	+1.24*	+1.24*	+1.24*	+1.24*

01/01/2019

1st	2nd	3rd	4th	5th	6th	7th	8th
18.42	18.42	19.30	20.16	21.03	21.91	22.79	23.65
+1.24*	+1.24*	+1.24*	+1.24*	+1.24*	+1.24*	+1.24*	+1.24*

* This portion of the benefit is NOT subject to the SAME PREMIUM as shown for overtime.

Carpenter - Building **01/01/2019**

JOB DESCRIPTION Carpenter - Building **DISTRICT 2**

ENTIRE COUNTIES

Clinton, Essex, Franklin

WAGES

Per hour:	07/01/2018	07/01/2019	07/01/2020
		Additional	Additional
Carpenter	\$ 27.17	\$ 1.00	\$ 1.00
Floor Coverer	27.17	1.00	1.00
Carpet Layer	27.17	1.00	1.00

Dry-Wall	27.17	1.00	1.00
Lather	27.17	1.00	1.00
Diver-Wet Day	61.25	0.00	0.00
Diver-Dry Day	28.17	1.00	1.00
Diver Tender	28.17	1.00	1.00

NOTE ADDITIONAL AMOUNTS PAID FOR THE FOLLOWING WORK LISTED BELOW (not subject to overtime premiums):

- Pile Drivers shall receive \$0.25 per hour over the journeyman's rate of pay when performing piledriving work.
- Certified welders shall receive \$1.00 per hour over the journeyman's rate of pay when the employee is required to be certified and performs DOT or ABS specified welding work
- When an employee performs work within a contaminated area on a State and/or Federally designated hazardous waste site, and where relevant State and/or Federal regulations require employees to be furnished and use or wear required forms of personal protection, then the employee shall receive his regular hourly rate plus \$1.50 per hour.
- Depth pay for Divers based upon deepest depth on the day of the dive:
 - 0' to 80' no additional fee
 - 81' to 100' additional \$.50 per foot
 - 101' to 150' additional \$0.75 per foot
 - 151" and deeper additional \$1.25 per foot
- Penetration pay for Divers based upon deepest penetration on the day of the dive:
 - 0' to 50' no additional fee
 - 51' to 100' additional \$.75 per foot
 - 101' and deeper additional \$1.00 per foot

Four (4), ten (10) hour days may be worked at straight time during a week, Monday thru Thursday. Friday may be used as a make-up day.

NOTE - In order to use the "4 Day/10 Hour Work schedule", as your normal schedule, you must submit an "Employer Registration for Use of 4 Day/10 Hour Work Schedule," form PW30.1; and there must be a dispensation of hours in place on the project. If the PW30.1 is not submitted you may be liable for overtime payments for work over 8 hours per day.

SUPPLEMENTAL BENEFITS

Per hour:

Journeyman \$ 19.89

OVERTIME PAY

See (B, E, *E2, Q) on OVERTIME PAGE

* Note - Saturday is payable at straight time if the employee misses work, except where a doctor's or hospital verification of illness is produced Monday through Friday when work was available to the employee.

HOLIDAY

Paid: See (1) on HOLIDAY PAGE

Overtime: See (5, 6) on HOLIDAY PAGE

Note: Any holiday which occurs on Sunday shall be observed the following Monday. If Christmas falls on a Saturday, it shall be observed on the prior Friday.

REGISTERED APPRENTICES

Wages per hour

FOR APPRENTICES INDENTURED PRIOR TO JANUARY 1, 2016

One year terms at the following percentage of Journeyman's base wage.

1st	2nd	3rd	4th
50%	60%	70%	80%

Supplemental Benefits per hour:

1st year term	\$ 11.06
2nd year term	11.06
3rd year term	13.66
4th year term	13.66

FOR APPRENTICES INDENTURED AFTER JANUARY 1, 2016

1,300 hour terms at the following percentage of Journeyman's base wage.

1st	2nd	3rd	4th	5th
50%	60%	65%	70%	80%

Supplemental Benefits per hour:

1st term	\$ 11.06
2nd term	11.06
3rd term	13.66
4th term	13.66
5th term	13.66

ADDITIONAL AMOUNTS PAID TO APPRENTICES FOR SPECIFIC TYPES OF WORK PERFORMED (not subject to overtime premiums):

- Pile Driving apprentices shall receive \$0.25 per hour when performing piledriving work.
- Certified welders shall receive \$1.00 per hour over the apprentices rate of pay when the apprentice is required to be certified and performs DOT or ABS specified welding work
- When an apprentice performs work within a contaminated area on a State and/or Federally designated hazardous waste site, and where relevant State and/or Federal regulations require the apprentice to be furnished and use or wear required forms of personal protection, then the apprentice shall receive his regular hourly rate plus \$1.50 per hour.

2-291B-Cli

Carpenter - Building / Heavy&Highway **01/01/2019**

JOB DESCRIPTION Carpenter - Building / Heavy&Highway

DISTRICT 2

ENTIRE COUNTIES

Albany, Allegany, Broome, Cattaraugus, Cayuga, Chautauqua, Chemung, Chenango, Clinton, Columbia, Cortland, Delaware, Erie, Essex, Franklin, Fulton, Genesee, Greene, Hamilton, Herkimer, Jefferson, Lewis, Livingston, Madison, Monroe, Montgomery, Niagara, Oneida, Onondaga, Ontario, Orleans, Oswego, Otsego, Rensselaer, Saratoga, Schenectady, Schoharie, Schuyler, Seneca, St. Lawrence, Steuben, Sullivan, Tioga, Tompkins, Ulster, Warren, Washington, Wayne, Wyoming, Yates

PARTIAL COUNTIES

Orange: The area lying on Northern side of Orange County demarcated by a line drawn from the Bear Mountain Bridge continuing east to the Bear Mountain Circle, continue North on 9W to the town of Cornwall where County Road 107 (also known as Quaker Rd) crosses under 9W, then east on County Road 107 to Route 32, then north on Route 32 to Orrs Mills Rd, then west on Orrs Mills Rd to Route 94, continue west and south on Route 94 to the Town of Chester, to the intersection of Kings Highway, continue south on Kings Highway to Bellvale Rd, west on Bellvale Rd to Bellvale Lakes Rd, then south on Bellvale Lakes Rd to Kain Rd, southeast on Kain Rd to Route 17A, then north and southeast along Route 17A to Route 210, then follow Route 210 to NJ Border.

WAGES

Wages per hour: 07/01/2018

Carpenter - ONLY for
 Artificial Turf/Synthetic
 Sport Surface \$ 30.40

Note - Does not include the operation of equipment. Please see Operating Engineers rates.

SUPPLEMENTAL BENEFITS

Per hour:

Journeyman \$ 22.43

OVERTIME PAY

See (B, E, Q, X) on OVERTIME PAGE

HOLIDAY

Paid: See (2, 17) on HOLIDAY PAGE
 Overtime: See (5, 6, 16) on HOLIDAY PAGE

Notes:

When a holiday falls upon a Saturday, it shall be observed on the preceding Friday. When a holiday falls upon a Sunday, it shall be observed on the following Monday.

An employee taking an unexcused day off the regularly scheduled day before or after a paid Holiday shall not receive Holiday pay.

REGISTERED APPRENTICES

Wages per hour:

One year terms at the following percentage of Journeyman's wage:

1st	2nd	3rd	4th
50%	60%	70%	80%

Supplemental Benefits per hour:

1st year term	\$ 11.15
2nd year term	11.15
3rd year term	13.75
4th year term	13.75

2-42AtSS

Carpenter - Heavy&Highway **01/01/2019**

JOB DESCRIPTION Carpenter - Heavy&Highway

DISTRICT 2

ENTIRE COUNTIES

Albany, Clinton, Essex, Franklin, Fulton, Greene, Hamilton, Montgomery, Rensselaer, Saratoga, Schenectady, Schoharie, Warren, Washington

WAGES

Per hour	07/01/2018
Carpenter	\$ 31.48
Piledriver	31.48
Diver-Wet Day	56.48
Diver-Dry Day	32.48
Diver-Tender	32.48

NOTE ADDITIONAL AMOUNTS PAID FOR THE FOLLOWING WORK LISTED BELOW (not subject to overtime premiums):

- When Heavy & Highway Millwright work is performed, the employee will receive an additional \$1.50 per hour for all hours worked (Rate effective till 4/30/19, on 5/1/19 refer to Millwright rate schedule for Heavy & Highway work).
- When project owner mandates a single irregular work shift, the employee will receive an additional \$2.00 per hour. A single irregular work shift can start any time from 5:00 p.m. to 1:00 a.m.
- State or Federal designated hazardous site, requiring protective gear shall be an additional \$2.00 per hour.
- Certified welders when required to perform welding work will receive an additional \$1.50 per hour.

ADDITIONAL NOTES PERTAINING TO DIVERS/TENDERS:

- Divers and Tenders shall receive one and one half (1 1/2) times their regular diver and tender rate of pay for Effluent and Slurry diving.
- Divers and tenders being paid at the specified rate for Effluent and Slurry diving shall have all overtime rates based on the specified rate plus the appropriate overtime rates (one and one half or two times the specified rate for Slurry and Effluent divers and tenders).
- The pilot of an ADS or submersible will receive one and one-half (1 1/2) times the Diver-Wet Day Rate for time submerged.
- Depth pay for Divers based upon deepest depth on the day of the dive:
 - 0' to 50' no additional fee
 - 51'to 100' additional \$.50 per foot
 - 101'to 150' additional \$0.75 per foot
 - 151'and deeper additional \$1.25 per foot
- Penetration pay for Divers based upon deepest penetration on the day of the dive:
 - 0' to 50' no additional fee
 - 51' to 100' additional \$.75 per foot
 - 101' and deeper additional \$1.00 per foot
- Diver rates applies to all hours worked on dive day.

Four (4), ten (10) hour days may be worked at straight time during a week, Monday thru Friday, provided the project duration is more than forty (40) hours.

NOTE - In order to use the '4 Day/10 Hour Work schedule', as your normal schedule, you must submit an 'Employer Registration for Use of 4 Day/10 Hour Work Schedule,' form PW30.1; and there must be a dispensation of hours in place on the project. If the PW30.1 is not submitted you may be liable for overtime payments for work over 8 hours per day.

SUPPLEMENTAL BENEFITS

Per hour:

Journeyman \$ 21.35

OVERTIME PAY

See (B, E, Q, X) on OVERTIME PAGE

HOLIDAY

Paid: See (2, 17) on HOLIDAY PAGE

Overtime: See (5, 6) on HOLIDAY PAGE

In the event a Holiday falls on a Saturday, the Friday before will be observed as a Holiday. If a Holiday falls on a Sunday, then Monday will be observed as a Holiday.

REGISTERED APPRENTICES

Wages per hour

FOR APPRENTICES INDENTURED PRIOR TO JANUARY 1, 2016

One year terms at the following percentage of Journeyman's base wage

1st	2nd	3rd	4th
50%	60%	70%	80%

Supplemental Benefits per hour:

1st year term	\$ 11.02
2nd year term	11.02
3rd year term	13.62
4th year term	13.62

FOR APPRENTICES INDENTURED AFTER JANUARY 1, 2016

1,300 hour terms at the following percentage of Journeyman's base wage

1st	2nd	3rd	4th	5th
50%	60%	65%	70%	80%

Supplemental Benefits per hour:

1st term	\$ 11.02
2nd term	11.02
3rd term	13.62
4th term	13.62
5th term	13.62

NOTE ADDITIONAL AMOUNTS PAID TO APPRENTICES FOR THE FOLLOWING WORK LISTED BELOW (not subject to overtime premiums):

- When Heavy & Highway Millwright work is performed, the employee will receive an additional \$1.50 per hour for all hours worked (Rate effective till 4/30/19, on 5/1/19 refer to Millwright rate schedule for Heavy & Highway work).
- When project owner mandates a single irregular work shift, the employee will receive an additional \$2.00 per hour. A single irregular work shift can start any time from 5:00 p.m. to 1:00 a.m.
- State or Federal designated hazardous site, requiring protective gear shall be an additional \$2.00 per hour.
- Certified welders when required to perform welding work will receive an additional \$1.50 per hour.

2-291HH-Alb

Electrician

01/01/2019

JOB DESCRIPTION Electrician

DISTRICT 6

ENTIRE COUNTIES

Clinton, Essex, Franklin, Jefferson, Lewis, St. Lawrence

WAGES

Per hour:	07/01/2018	04/01/2019	04/01/2020	04/01/2021
		Additional	Additional	Additional
Electrician	\$ 34.50	\$ 1.50	\$ 1.55	\$ 1.60
Teledata	34.50			
Welder	36.50			

NOTE: Additional premiums for the following work listed:

- Additional \$1.50 per hour for work performed underground such as tunnels and mine shafts. Excludes manholes and walkway tunnels between buildings.
- Additional \$1.50 per hour for working 35 feet or more on scaffolds, ladders, towers, steeples, structural steel, or mechanical lifts over 65 feet.

Shift Work: The following rates will apply on all Contracting Agency mandated shifts worked between the hours listed below. The employer may be permitted to adjust the starting hours of the shift by up to two (2) hours if required by the agency. If a shift begins outside of the stated shift hours, the rate paid would be determined by what shift the majority of the hours were worked.

1st shift:	8:00 AM to 4:30 PM regular wage rate
2nd shift:	4:30 PM to 1:00 AM regular wage rate plus 17.3%
3rd shift:	12:30 AM to 9:00 AM regular wage rate plus 31.4%

**** IMPORTANT NOTICE - EFFECTIVE 07/01/2012 ****

Four (4), ten (10) hour days may be worked at straight time during a week, Monday thru Thursday. Friday may be used as a make-up day. NOTE - In order to use the '4 Day/10 Hour Work schedule', as your normal schedule, you must submit an 'Employer Registration for Use of 4 Day/10 Hour Work Schedule,' form PW30.1; and there must be a dispensation of hours in place on the project. If the PW30.1 is not submitted you may be liable for overtime payments for work over 8 hours per day.

SUPPLEMENTAL BENEFITS

Per hour:	\$ 19.68
	* plus 5.75% of gross wage

* NOTE: THE 5.75% IS BASED ON THE HOURLY WAGE PAID, STRAIGHT TIME RATE OR PREMIUM TIME RATE.

OVERTIME PAY

See (B, E, Q) on OVERTIME PAGE

NOTE: WAGE CAP...Double the straight time hourly base wage shall be the maximum hourly wage compensation for any hour worked. Contractor is still responsible to pay the hourly benefit amount for each hour worked.

HOLIDAY

Paid:	See (1) on HOLIDAY PAGE
Overtime:	See (5, 6) on HOLIDAY PAGE

REGISTERED APPRENTICES

WAGES: Hourly terms at the following percentage of Journeyman's wage.

1-1000	to 2000	to 3500	to 5000	to 6500	to 8000
45%	50%	55%	60%	70%	80%

Electrician	\$15.52	\$17.25	\$18.97	\$20.70	\$24.15	\$27.60
Tunnel	\$17.02	\$18.75	\$20.47	\$22.20	\$25.65	\$29.10

SUPPLEMENTAL BENEFITS per hour:

Appr 1st & 2nd term	\$ 9.37 * plus 5.75% of gross wage
Appr All other terms	\$ 19.68 * plus 5.75% of gross wage

* NOTE: THE 5.75% IS BASED ON THE HOURLY WAGE PAID, STRAIGHT TIME RATE OR PREMIUM TIME RATE.

6-910

Elevator Constructor

01/01/2019

JOB DESCRIPTION Elevator Constructor

DISTRICT 1

ENTIRE COUNTIES

Albany, Clinton, Essex, Fulton, Hamilton, Herkimer, Montgomery, Otsego, Rensselaer, Saratoga, Schenectady, Schoharie, Warren, Washington

PARTIAL COUNTIES

Madison: Madison Only the towns of: Brookfield, Hamilton, Lincoln, Madison, Smithfield, Stockbridge and the City of Oneida
 Oneida: Entire county except the towns of: Camden, Florence, and Vienna.

WAGES

Per hour	07/01/2018	01/01/2019
Mechanic	\$ 44.58	\$ 46.00
Helper	70% of Mechanic Wage Rate	70% of Mechanic Wage Rate

Four (4), ten (10) hour days may be worked at straight time during a week, Monday thru Thursday or Tuesday thru Friday.

NOTE - In order to use the "4 Day/10 Hour Work schedule", as your normal schedule, you must submit an "Employer Registration for Use of 4 Day/10 Hour Work Schedule," form PW30.1; and there must be a dispensation of hours in place on the project. If the PW30.1 is not submitted you may be liable for overtime payments for work over 8 hours per day.

SUPPLEMENTAL BENEFITS

Per hour	07/01/2018	01/01/2019
Journeyman/Helper	\$ 32.645*	\$ 33.705*

(*)Plus 6% of hourly rate, if less than 5 years of service. Plus 8% of hourly rate, if more than 5 years of service.

OVERTIME PAY

See (D, O) on OVERTIME PAGE

HOLIDAY

Paid: See (5, 6, 15, 16) on HOLIDAY PAGE
 Overtime: See (5, 6, 15, 16) on HOLIDAY PAGE

Note: When a paid holiday falls on Saturday, it shall be observed on Friday. When a paid holiday falls on Sunday, it shall be observed on Monday.

REGISTERED APPRENTICES

Wages per hour:				
0-6 mo*	6-12 mo	2nd yr	3rd yr	4th yr
50%	55 %	65 %	70 %	80 %

(*)Plus 6% of the hourly rate, no additional supplemental benefits.

Supplemental Benefits - per hour worked:

Same as Journeyman/Helper

Glazier **01/01/2019**

JOB DESCRIPTION Glazier

DISTRICT 1

ENTIRE COUNTIES

Albany, Clinton, Columbia, Essex, Franklin, Fulton, Greene, Hamilton, Montgomery, Rensselaer, Saratoga, Schenectady, Schoharie, Warren, Washington

WAGES

Per hour

07/01/2018

Glazier base wage \$ 27.65
 + additional \$2.20 per hour for all hours worked

*High Work Base Wage 31.00
 + additional \$3.52 per hour for all hours worked

(*)When working on Swing Stage or Lift 100 feet or more in height, measured from the ground level up.

Four (4), ten (10) hour days may be worked at straight time during a week, Monday thru Thursday. Friday may be used as a make-up day.
 NOTE - In order to use the '4 Day/10 Hour Work schedule', as your normal schedule, you must submit an 'Employer Registration for Use of 4 Day/10 Hour Work Schedule,' form PW30.1; and there must be a dispensation of hours in place on the project. If the PW30.1 is not submitted you may be liable for overtime payments for work over 8 hours per day.

SUPPLEMENTAL BENEFITS

Per hour

Journeyman \$ 19.81
 Journeyman
 High Work 24.69

OVERTIME PAY

See (B, E, E2, Q) on OVERTIME PAGE
 Premium is applied to the respective base wage only.

HOLIDAY

Paid: See (1) on HOLIDAY PAGE
 Overtime: See (5, 6) on HOLIDAY PAGE

Note: If any of the holidays are designated by federal law to be celebrated on a day other than that on which they regularly fall, then the holiday shall be celebrated on the day set by said federal law as if the day on which the holiday is celebrated was actually the holiday date.

REGISTERED APPRENTICES

Wages per hour

Apprentice Glazier One Year and 1500 hr. terms at the following percentage of Journeyman's base wage.

1st	2nd	3rd	4th
50%	65%	75%	90%

+ additional \$2.20 per hour for all hours worked for all terms

Apprentice Glazier Hi-Work One Year and 1500 hr. terms at the following percentage of Journeyman's Hi-Work base wage.

1st	2nd	3rd	4th
50%	65%	75%	90%

+ additional \$3.52 per hour for all hours worked for all terms

Supplemental Benefits per hour worked

Apprentice	
1st-2nd term	\$ 16.14
3rd-4th term	19.81
Apprentice High Work	
1st-2nd term	18.69
3rd-4th term	24.69

Insulator - Heat & Frost **01/01/2019**

JOB DESCRIPTION Insulator - Heat & Frost

DISTRICT 1

ENTIRE COUNTIES

Albany, Columbia, Delaware, Essex, Fulton, Greene, Hamilton, Montgomery, Rensselaer, Saratoga, Schenectady, Schoharie, Sullivan, Ulster, Warren, Washington

WAGES

Wages per hour 07/01/2018

Asbestos Worker*	\$ 34.90
Insulator*	34.90
Firestopping Worker*	29.67

(*)On Mechanical Systems only.

On government mandated shift work additional 12% of wage for all shifts starting after 3:30 P.M.

SUPPLEMENTAL BENEFITS

Per hour

Journeyman \$ 21.94

OVERTIME PAY

See (*B1, **Q) on OVERTIME PAGE

*B1=Double time begins after 10 hours on Saturday

**Q=Triple time on Labor Day if worked.

HOLIDAY

Paid: See (1) on HOLIDAY PAGE

Overtime: See (5, 6) on HOLIDAY PAGE

When a holiday falls on Sunday the following Monday shall be observed as the holiday.

REGISTERED APPRENTICES

Wages per hour

one year terms at the following percentage of Journeyman's wage.

1st	2nd	3rd	4th
60 %	70 %	80 %	90 %

Supplemental Benefits per hour worked:

Apprentices \$ 21.94

1-40

Ironworker

01/01/2019

JOB DESCRIPTION Ironworker

DISTRICT 1

ENTIRE COUNTIES

Albany, Clinton, Columbia, Delaware, Essex, Greene, Rensselaer, Saratoga, Schenectady, Schoharie, Warren, Washington

PARTIAL COUNTIES

Fulton: Only the Townships of Broadalbin, Mayfield, Northampton, Perth, Bleecker and Johnstown.

Hamilton: Only the Townships of Hope, Benson and Wells.

Montgomery: Only the Townships of Florida, Amsterdam, Charleston, Glen, Mohawk and Root.

Otsego: Only the Towns of Unadilla, Butternuts, Morris, Otego, Oneonta, Laurens, Millford, Maryland and Worcester.

WAGES

Wages 07/01/2018

Per hour

Ornamental	\$ 31.00
Reinforcing	31.00
Rodman	31.00
Structural & Precast	31.00
Mover/Rigger	31.00
Fence Erector	31.00
Stone Derrickman	31.00
Sheeter	31.25
Curtain Wall Installer	31.00
Metal Window Installer	31.00

SUPPLEMENTAL BENEFITS

Per hour

JOURNEYMAN \$ 28.11

OVERTIME PAY

See (B, E, Q) on OVERTIME PAGE

HOLIDAY

Paid: See (1) on HOLIDAY PAGE

Overtime: See (5, 6) on HOLIDAY PAGE

Note: Any holiday which occurs on Sunday shall be observed the following Monday.

REGISTERED APPRENTICES

Wages per hour

ONE YEAR TERMS AT THE FOLLOWING WAGE RATES:

07/01/2018

1st year	\$ 16.50
2nd year	18.50
3rd year	20.50
4th year	22.50

Supplemental Benefits per hour worked

1st year	\$ 11.00
2nd year	21.86
3rd year	23.40
4th year	24.96

1-12

Laborer - Building

01/01/2019

JOB DESCRIPTION Laborer - Building

DISTRICT 7

ENTIRE COUNTIES

Clinton, Essex, Warren

WAGES

GROUP #A: All Laborers (except as noted)

GROUP #B: Asbestos & Hazardous Waste Work.

WAGES per hour

	07/01/2018	07/01/2019
Group # A	\$ 23.68	Additional \$ 1.50
Group # B	25.18	1.50

SUPPLEMENTAL BENEFITS

Per hour:

Journeyman \$ 21.60

OVERTIME PAY

See (B, E, E2, Q) on OVERTIME PAGE

HOLIDAY

Paid: See (1) on HOLIDAY PAGE

Overtime: See (5, 6) on HOLIDAY PAGE

REGISTERED APPRENTICES

Wages per hour

Terms are at the following percentage of Group Rate A.

0-1,000 Hrs	1,001-2,000 Hrs	2,001-3,000 Hrs	3,001-4,000 Hrs
60%	70%	80%	90%

SUPPLEMENTAL BENEFITS per hour worked:

All Terms: Same as Journeyman

7-1822ew

Laborer - Heavy&Highway

01/01/2019

JOB DESCRIPTION Laborer - Heavy&Highway

DISTRICT 7

ENTIRE COUNTIES
Clinton, Essex, Warren

WAGES
Per hour:

GROUP A: Drill Helper, Flagmen, Outboard and Hand Boats.

GROUP B: BASIC RATE: Bull Float (where used for strike off only), Chain Saw, Concrete Aggregate Bin, Concrete Bootman, Gin Buggy, Hand or Machine Vibrator, Jack Hammer, Mason Tender, Mortar Mixer, Pavement Breaker, Handlers of All Steel Mesh, Small Generators for Laborers' Tools, Installation of Bridge Drainage Pipe, Pipe Layers, Vibrator Type Rollers, Tamper, Drill Doctor, Water Pump Operator (1-1/2" and Single Diaphragm) Nozzle (Asphalt, Guniting, Seeding, and Sand Blasting), Laborers on Chain Link Fence Erection, Rock Splitter & Power Unit, Pusher Type Concrete Saw and All Other Gas, Electric, Oil, and Air Tool Operators, Wrecking Laborer.

GROUP C: Drilling Equipment - only where a separate air compressor unit supplies power, Acetylene Torch Operators, Asphalt Raker, Powder Man, Tail or Screw Operator on Asphalt Paver.

GROUP D: Blasters, Form Setters, Stone or Granite Curb Setters.

GROUP E: Hazardous Waste Removal Work when designated by State/Federal as hazardous waste site and regulations require employees wear required personal protection.

WAGES per hour 07/01/2018

Group # A	\$ 25.47
Group # B	25.67
Group # C	25.87
Group # D	26.07
Group # E	27.67

NOTE: A single irregular work shift starting any time between 5:00 PM and 1:00 AM on governmental mandated night work shall be paid an additional \$2.00 per hour.

IMPORTANT NOTE: Operation of equipment (i.e. forklift, skid steer) is the work of the Operating Engineers, please see appropriate rates.

SUPPLEMENTAL BENEFITS

Per hour:

Journeyman \$ 23.85

OVERTIME PAY

See (B, E, Q) on OVERTIME PAGE

HOLIDAY

Paid: See (5, 6) on HOLIDAY PAGE

Overtime: See (5, 6) on HOLIDAY PAGE

NOTE: If a holiday falls on Sunday, it will be celebrated on Monday. In the event that men work on this Sunday holiday, they shall be paid double time. In the event that men work on Monday, they shall be compensated at double time plus the holiday pay. Accordingly, the Monday following the Sunday is treated as the holiday.

REGISTERED APPRENTICES

WAGES: 1000 hour terms at the following percentage of Journeyman's wage.

1st	2nd	3rd	4th
60%	70%	80%	90%

SUPPLEMENTAL BENEFITS per hour worked:

All Terms: Same as Journeyman

7-1822/2h

Laborer - Tunnel

01/01/2019

JOB DESCRIPTION Laborer - Tunnel

DISTRICT 7

ENTIRE COUNTIES
Clinton, Essex, Warren

WAGES

GROUP A: General Laborer

GROUP B: Change Houseman, Miners and all Machine Men, Safety Miner, all Shaft-work, Caisson work, Drilling, Blow Pipe, all Air Tools, Tugger, Scaling, Nipper, Guniting pot to nozzle, Bit Grinder, Signal Man (top and bottom), Concrete Men, Shield driven tunnels, mixed face and soft ground, liner plate tunnels in free air.

GROUP C: Hazardous/Waste Work

WAGES (per hour)

07/01/2018

Tunnel Laborer:

Group A	\$ 28.65
Group B	28.85
Group C*	30.65

(*)Work site required to be designated by State/Federal as hazardous waste site and relevant regulations require employees to use personal protection.

SUPPLEMENTAL BENEFITS

Per hour:

Journeyman \$ 23.85

OVERTIME PAY

See (B, E, Q) on OVERTIME PAGE

HOLIDAY

Paid: See (5, 6) on HOLIDAY PAGE

Overtime: See (5, 6) on HOLIDAY PAGE

NOTE: If a holiday falls on Saturday, it will be celebrated on Friday. If a holiday falls on Sunday, it will be celebrated on Monday. In the event that men work on this Sunday holiday, they shall be paid double time. In the event that men work on Monday, they shall be compensated at double time plus the holiday pay. Accordingly, the Monday following the Sunday is treated as the holiday.

REGISTERED APPRENTICES

Wages per hour

Terms are at the following percentage of Group B rate.

0-1000 Hrs	1001-2000 Hrs	2001-3000 Hrs	3001-4000 Hrs
60%	70%	80%	90%

SUPPLEMENTAL BENEFITS

All Terms: Same as Journeyman

7-1822T

Lineman Electrician

01/01/2019

JOB DESCRIPTION Lineman Electrician

DISTRICT 6

ENTIRE COUNTIES

Albany, Allegany, Broome, Cattaraugus, Cayuga, Chautauqua, Chemung, Chenango, Clinton, Columbia, Cortland, Delaware, Dutchess, Erie, Essex, Franklin, Fulton, Genesee, Greene, Hamilton, Herkimer, Jefferson, Lewis, Livingston, Madison, Monroe, Montgomery, Niagara, Oneida, Onondaga, Ontario, Orange, Orleans, Oswego, Otsego, Putnam, Rensselaer, Rockland, Saratoga, Schenectady, Schoharie, Schuyler, Seneca, St. Lawrence, Steuben, Sullivan, Tioga, Tompkins, Ulster, Warren, Washington, Wayne, Wyoming, Yates

WAGES

Per hour:

NOTE: Includes Teledata Work within ten (10) feet of High Voltage Transmission Lines

Below rates applicable on all overhead and underground distribution and maintenance work, and all overhead and underground transmission line work and the installation of fiber optic cable where no other construction trades are or have been involved. (Ref #14.01.01)

	07/01/2018	05/06/2019	05/04/2020
Lineman, Technician	\$ 50.60	\$ 52.05	\$ 53.50
Crane, Crawler Backhoe	50.60	52.05	53.50
Welder, Cable Splicer	50.60	52.05	53.50
Digging Mach. Operator	45.54	46.85	48.15
Tractor Trailer Driver	43.01	44.24	45.48
Groundman, Truck Driver	40.48	41.64	42.80
Equipment Mechanic	40.48	41.64	42.80
Flagman	30.36	31.23	32.10

Additional \$1.00 per hour for entire crew when a helicopter is used.

Below rates applicable on all electrical sub-stations, switching structures, fiber optic cable and all other work not defined as "Utility outside electrical work". (Ref #14.02.01-A)

Lineman, Technician	\$ 50.60	\$ 52.05	\$ 53.50
Crane, Crawler Backhoe	50.60	52.05	53.50
Cable Splicer	55.66	57.26	58.85
Certified Welder -			
Pipe Type Cable	53.13	54.65	56.18
Digging Mach. Operator	45.54	46.85	48.15
Tractor Trailer Driver	43.01	44.24	45.48
Groundman, Truck Driver	40.48	41.64	42.80
Equipment Mechanic	40.48	41.64	42.80
Flagman	30.36	31.23	32.10

Additional \$1.00 per hour for entire crew when a helicopter is used.

Below rates apply on switching structures, maintenance projects, railroad catenary install/maintenance third rail installation, bonding of rails and pipe type cable and installation of fiber optic cable. (Ref #14.02.01-B)

Lineman, Tech, Welder	\$ 51.92	\$ 53.37	\$ 54.82
Crane, Crawler Backhoe	51.92	53.37	54.82
Cable Splicer	57.11	58.71	60.30
Certified Welder -			
Pipe Type Cable	54.52	56.04	57.56
Digging Mach. Operator	46.73	48.03	49.34
Tractor Trailer Driver	44.13	45.36	46.60
Groundman, Truck Driver	41.54	42.70	43.86
Equipment Mechanic	41.54	42.70	43.86
Flagman	31.15	32.02	32.89

Additional \$1.00 per hour for entire crew when a helicopter is used.

Below rates applicable on all overhead and underground transmission line work & fiber optic cable where other construction trades are or have been involved. This applies to transmission line work only, not other construction. (Ref #14.03.01)

Lineman, Tech, Welder	\$ 53.11	\$ 54.56	\$ 56.01
Crane, Crawler Backhoe	53.11	54.56	56.01
Cable Splicer	53.11	54.56	56.01
Digging Mach. Operator	47.80	49.10	50.41
Tractor Trailer Driver	45.14	46.38	47.61
Groundman, Truck Driver	42.49	43.65	44.81
Equipment Mechanic	42.49	43.65	44.81
Flagman	31.87	32.74	33.61

Additional \$1.00 per hour for entire crew when a helicopter is used.

NOTE: THE FOLLOWING RATES WILL APPLY ON ALL CONTRACTING AGENCY MANDATED MULTIPLE SHIFTS OF AT LEAST FIVE (5) DAYS DURATION WORKED BETWEEN THE HOURS LISTED BELOW:

1ST SHIFT	8:00 AM to 4:30 PM REGULAR RATE
2ND SHIFT	4:30 PM to 1:00 AM REGULAR RATE PLUS 17.3 %
3RD SHIFT	12:30 AM to 9:00 AM REGULAR RATE PLUS 31.4 %

**** IMPORTANT NOTICE ****

Four (4), ten (10) hour days may be worked at straight time during a week, Monday thru Thursday. Friday may be used as a make-up day.
 *Effective 05/06/2013, Tuesday thru Friday may be worked with no make-up day.

NOTE - In order to use the '4 Day/10 Hour Work schedule', as your normal schedule, you must submit an 'Employer Registration for Use of 4 Day/10 Hour Work Schedule,' form PW30.1; and there must be a dispensation of hours in place on the project. If the PW30.1 is not submitted you may be liable for overtime payments for work over 8 hours per day.

SUPPLEMENTAL BENEFITS

Per hour worked (also required on non-worked holidays):

The following SUPPLEMENTAL BENEFITS apply to all classification categories of CONSTRUCTION, TRANSMISSION and DISTRIBUTION.

Journeyman	\$ 23.40 *plus 6.75% of hourly wage	\$ 24.15 *plus 6.75% of hourly wage	\$ 24.90 *plus 6.75% of hourly wage
------------	---	---	---

*The 6.75% is based on the hourly wage paid, straight time rate or premium rate.

OVERTIME PAY

See (B, E, Q,) on OVERTIME PAGE. *Note* Double time for all emergency work designated by the Dept. of Jurisdiction.
 NOTE: WAGE CAP...Double the straight time hourly base wage shall be the maximum hourly wage compensation for any hour worked.
 Contractor is still responsible to pay the hourly benefit amount for each hour worked.

HOLIDAY

Paid See (5, 6, 8, 13, 25) on HOLIDAY PAGE plus Governor of NYS Election Day.
 Overtime See (5, 6, 8, 13, 25) on HOLIDAY PAGE plus Governor of NYS Election Day.

NOTE: All paid holidays falling on Saturday shall be observed on the preceding Friday. All paid holidays falling on Sunday shall be observed on the following Monday. Supplements for holidays paid at straight time.

REGISTERED APPRENTICES

WAGES: 1000 hour terms at the following percentage of the applicable Journeyman Lineman wage.

1st	2nd	3rd	4th	5th	6th	7th
60%	65%	70%	75%	80%	85%	90%

SUPPLEMENTAL BENEFITS: Same as Journeyman

6-1249a

Lineman Electrician - Teledata 01/01/2019

JOB DESCRIPTION Lineman Electrician - Teledata **DISTRICT 6**

ENTIRE COUNTIES

Albany, Allegany, Broome, Cattaraugus, Cayuga, Chautauqua, Chemung, Chenango, Clinton, Columbia, Cortland, Delaware, Dutchess, Erie, Essex, Franklin, Fulton, Genesee, Greene, Hamilton, Herkimer, Jefferson, Lewis, Livingston, Madison, Monroe, Montgomery, Niagara, Oneida, Onondaga, Ontario, Orange, Orleans, Oswego, Otsego, Putnam, Rensselaer, Rockland, Saratoga, Schenectady, Schoharie, Schuyler, Seneca, St. Lawrence, Steuben, Sullivan, Tioga, Tompkins, Ulster, Warren, Washington, Wayne, Westchester, Wyoming, Yates

WAGES

Per hour:

For outside work, stopping at first point of attachment (demarcation).

	07/01/2018	01/01/2019	01/01/2020	01/01/2021
Cable Splicer	\$ 31.83	\$ 32.78	\$ 33.77	\$ 34.78
Installer, Repairman	30.21	\$ 31.12	\$ 32.05	\$ 33.01
Teledata Lineman	30.21	\$ 31.12	\$ 32.05	\$ 33.01
Tech., Equip. Operator	30.21	\$ 31.12	\$ 32.05	\$ 33.01
Groundman	16.01	\$ 16.49	\$ 16.99	\$ 17.50

NOTE: EXCLUDES Teledata work within ten (10) feet of High Voltage (600 volts and over) transmission lines. For this work please see LINEMAN.

NOTE: THE FOLLOWING RATES WILL APPLY ON ALL CONTRACTING AGENCY MANDATED MULTIPLE SHIFTS OF AT LEAST FIVE (5) DAYS DURATION WORKED:

1ST SHIFT	REGULAR RATE
2ND SHIFT	REGULAR RATE PLUS 10%
3RD SHIFT	REGULAR RATE PLUS 15%

SUPPLEMENTAL BENEFITS

Per hour:

Journeyman	\$ 4.73 *plus 3% of wage paid	\$ 4.73 *plus 3% of wage paid	\$ 4.73 *plus 3% of wage paid	\$ 4.73 *plus 3% of wage paid
------------	-------------------------------------	-------------------------------------	-------------------------------------	-------------------------------------

*The 3% is based on the hourly wage paid, straight time rate or premium rate.

OVERTIME PAY

See (B, E, Q) on OVERTIME PAGE

NOTE: WAGE CAP...Double the straight time hourly base wage shall be the maximum hourly wage compensation for any hour worked. Contractor is still responsible to pay the hourly benefit amount for each hour worked.

HOLIDAY

Paid: See (1) on HOLIDAY PAGE
 Overtime: See (5, 6, 16) on HOLIDAY PAGE

6-1249LT - Teledata

Lineman Electrician - Traffic Signal, Lighting **01/01/2019**

JOB DESCRIPTION Lineman Electrician - Traffic Signal, Lighting **DISTRICT 6**

ENTIRE COUNTIES

Albany, Allegany, Broome, Cattaraugus, Cayuga, Chautauqua, Chemung, Chenango, Clinton, Cortland, Delaware, Erie, Essex, Franklin, Fulton, Genesee, Greene, Hamilton, Herkimer, Jefferson, Lewis, Livingston, Madison, Monroe, Montgomery, Niagara, Oneida, Onondaga, Ontario, Orleans, Oswego, Otsego, Rensselaer, Saratoga, Schenectady, Schoharie, Schuyler, Seneca, St. Lawrence, Steuben, Sullivan, Tioga, Tompkins, Warren, Washington, Wayne, Wyoming, Yates

WAGES

Lineman/Technician shall perform all overhead aerial work. A Lineman/Technician on the ground will install all electrical panels, connect all grounds, install and connect all electrical conductors which includes, but is not limited to road loop wires; conduit and plastic or other type pipes that carry conductors, flex cables and connectors, and to oversee the encasement or burial of such conduits or pipes.

A Groundman/Groundman Truck Driver shall: Build and set concrete forms, handle steel mesh, set footer cages, transport concrete in a wheelbarrow, hand or machine concrete vibrator, finish concrete footers, mix mortar, grout pole bases, cover and maintain footers while curing in cold weather, operate jack hammer, operate hand pavement breaker, tamper, concrete and other motorized saws, as a drill helper, operate and maintain generators, water pumps, chainsaws, sand blasting, operate mulching and seeding machine, air tools, electric tools, gas tools, load and unload materials, hand shovel and/or broom, prepare and pour mastic and other fillers, assist digger operator equipment operator in ground excavation and restoration, landscape work and painting. Only when assisting a lineman technician, a groundman/groundman truck driver may assist in installing conduit, pipe, cables and equipment.

A flagger's duties shall consist of traffic control only.
 (Ref #14.01.01)

Per hour:	07/01/2018	05/06/2019	05/04/2020
Lineman, Technician	\$ 43.80	\$ 45.00	\$ 46.20
Crane, Crawler Backhoe	43.80	45.00	46.20
Certified Welder	45.99	47.25	48.51
Digging Machine	39.42	40.50	41.58
Tractor Trailer Driver	37.23	38.25	39.27
Groundman, Truck Driver	35.04	36.00	36.96
Equipment Mechanic	35.04	36.00	36.96
Flagman	26.28	27.00	27.72

Above rates applicable on all Lighting and Traffic Signal Systems with the installation, testing, operation, maintenance and repair of all traffic control and illumination projects, traffic monitoring systems, road weather information systems and the installation of Fiber Optic Cable.

NOTE: THE FOLLOWING RATES WILL APPLY ON ALL CONTRACTING AGENCY MANDATED MULTIPLE SHIFTS OF AT LEAST FIVE (5) DAYS DURATION WORKED BETWEEN THE HOURS LISTED BELOW:

1ST SHIFT	8:00 AM TO 4:30 PM	REGULAR RATE
2ND SHIFT	4:30 PM TO 1:00 AM	REGULAR RATE PLUS 17.3%
3RD SHIFT	12:30 AM TO 9:00 AM	REGULAR RATE PLUS 31.4%

**** IMPORTANT NOTICE ****

Four (4), ten (10) hour days may be worked at straight time during a week, Monday thru Thursday. Friday may be used as a make-up day.
 *Effective 05/06/2013, Tuesday thru Friday may be worked with no make-up day.

NOTE - In order to use the '4 Day/10 Hour Work schedule', as your normal schedule, you must submit an 'Employer Registration for Use of 4 Day/10 Hour Work Schedule,' form PW30.1; and there must be a dispensation of hours in place on the project. If the PW30.1 is not submitted you may be liable for overtime payments for work over 8 hours per day.

SUPPLEMENTAL BENEFITS

Per hour worked (but also required on non-worked holidays):

Journeyman	\$ 23.40	\$ 24.15	\$ 24.90
------------	----------	----------	----------

*plus 6.75% of
 hourly wage

*plus 6.75% of
 hourly wage

*plus 6.75% of
 hourly wage

*The 6.75% is based on the hourly wage paid, straight time rate or premium rate.
 Supplements paid at STRAIGHT TIME rate for holidays.

OVERTIME PAY

See (B, E, Q) on OVERTIME PAGE. *Note* Double time for all emergency work designated by the Dept. of Jurisdiction.
 NOTE: WAGE CAP...Double the straight time hourly base wage shall be the maximum hourly wage compensation for any hour worked.
 Contractor is still responsible to pay the hourly benefit amount for each hour worked.

HOLIDAY

Paid: See (5, 6, 8, 13, 25) on HOLIDAY PAGE plus Governor of NYS Election Day.
 Overtime: See (5, 6, 8, 13, 25) on HOLIDAY PAGE plus Governor of NYS Election Day.

NOTE: All paid holidays falling on Saturday shall be observed on the preceding Friday. All paid holidays falling on Sunday shall be observed on the following Monday. Supplements for holidays paid at straight time.

REGISTERED APPRENTICES

WAGES: Per hour. 1000 hour terms.

	07/01/2018	05/06/2019	05/04/2020
1st term	\$ 26.28	\$ 27.00	\$ 27.72
2nd term	28.47	29.25	30.03
3rd term	30.66	31.50	32.34
4th term	32.85	33.75	34.65
5th term	35.04	36.00	36.96
6th term	37.23	38.25	39.27
7th term	39.42	40.50	41.58

SUPPLEMENTAL BENEFITS: Same as Journeyman

6-1249a-LT

Lineman Electrician - Tree Trimmer

01/01/2019

JOB DESCRIPTION Lineman Electrician - Tree Trimmer

DISTRICT 6

ENTIRE COUNTIES

Albany, Allegany, Broome, Cattaraugus, Cayuga, Chautauqua, Chemung, Chenango, Clinton, Columbia, Cortland, Delaware, Dutchess, Erie, Essex, Franklin, Fulton, Genesee, Greene, Hamilton, Herkimer, Jefferson, Lewis, Livingston, Madison, Monroe, Montgomery, Niagara, Oneida, Onondaga, Ontario, Orange, Orleans, Oswego, Otsego, Putnam, Rensselaer, Rockland, Saratoga, Schenectady, Schoharie, Schuyler, Seneca, St. Lawrence, Steuben, Sullivan, Tioga, Tompkins, Ulster, Warren, Washington, Wayne, Wyoming, Yates

WAGES

Per hour:

Applies to line clearance, tree work and right-of-way preparation on all new or existing energized overhead or underground electrical, telephone and CATV lines. This also would include stump removal near underground energized electrical lines, including telephone and CATV lines.

	07/01/2018	01/01/2019
Tree Trimmer	\$ 25.10	\$ 25.79
Equipment Operator	22.20	22.81
Equipment Mechanic	22.20	22.81
Truck Driver	18.48	18.99
Groundman	15.22	15.64
Flag person	10.97	11.27

SUPPLEMENTAL BENEFITS

Per hour worked (but also required on non-worked holidays):

Journeyman	\$ 9.98	\$ 9.98
	*plus 3% of hourly wage	*plus 3% of hourly wage

* The 3% is based on the hourly wage paid, straight time rate or premium rate.

OVERTIME PAY

See (B, E, Q) on OVERTIME PAGE
 NOTE: WAGE CAP...Double the straight time hourly base wage shall be the maximum hourly wage compensation for any hour worked.
 Contractor is still responsible to pay the hourly benefit amount for each hour worked.

HOLIDAY

Paid: See (5, 6, 8, 15, 16, 25) on HOLIDAY PAGE
Overtime: See (5, 6, 8, 15, 16, 25) on HOLIDAY PAGE

NOTE: All paid holidays falling on a Saturday shall be observed on the preceding Friday.
All paid holidays falling on a Sunday shall be observed on the following Monday.

6-1249TT

Mason - Building

01/01/2019

JOB DESCRIPTION Mason - Building

DISTRICT 12

ENTIRE COUNTIES

Albany, Clinton, Columbia, Essex, Franklin, Fulton, Greene, Hamilton, Montgomery, Rensselaer, Saratoga, Schenectady, Schoharie, Warren, Washington

WAGES

Per hour 07/01/2018

Tile/Marble/Terrazzo

Setter \$ 34.66
Finisher 27.16

Four (4), ten (10) hour days may be worked at straight time during a week, Monday thru Thursday. Friday may be used as a make-up day.

NOTE - In order to use the '4 Day/10 Hour Work Schedule,' as your normal schedule, you must submit an 'Employer Registration for Use of 4 Day/10 Hour Work Schedule,' form PW30.1; and there must be a dispensation of hours in place on the project. If the PW30.1 is not submitted you may be liable for overtime payments for work over 8 hours per day.

SUPPLEMENTAL BENEFITS

Per hour worked

Journeyman Setter \$ 19.58
Journeyman Finisher 16.85

OVERTIME PAY

See (B, E, E2, Q) on OVERTIME PAGE

HOLIDAY

Paid: See (1) on HOLIDAY PAGE
Overtime: See (5, 6) on HOLIDAY PAGE

REGISTERED APPRENTICES

Wages per hour

Hour Terms at the following percentage of Journeyman's wage

Setter:
1st term 0-500 hrs 60%
2nd term 501-1500 hrs 70%
3rd term 1501-2500 hrs 80%
4th term 2501-3500 hrs 85%
5th term 3501-4500 hrs 90%
6th term 4501-6000 hrs 95%

Finisher:
1st term 0-500 hrs 70%
2nd term 501-1500 hrs 80%
3rd term 1501-2500 hrs 90%
4th term 2501-3700 hrs 95%

Supplemental Benefits per hour worked
07/01/2018

Setter:
1st term 0-500 hrs \$ 11.23
2nd term 501-1500 hrs 11.23
3rd term 1501-2500 hrs 15.40
4th term 2501-3500 hrs 15.40
5th term 3501-4500 hrs 17.47
6th term 4501-6000 hrs 19.58

Finisher:	
1st term 0-500 hrs	\$ 10.70
2nd term 501-1500 hrs	10.70
3rd term 1501-2500 hrs	13.77
4th term 2501-3700 hrs	13.77

12-2TS.1

Mason - Building

01/01/2019

JOB DESCRIPTION Mason - Building

DISTRICT 12

ENTIRE COUNTIES

Clinton, Essex, Franklin

PARTIAL COUNTIES

Warren: Only the Townships of Chester, Hague, Horicon and Johnsburg.

WAGES

Per hour 07/01/2018

Bricklayer	\$ 31.98
Cement Finisher	31.98
Plasterer/Fireproofers*	31.98
Pointer/Caulker/Cleaner	31.98
Stone Mason	31.98
Acid Brick	32.48

(*)Fireproofers on Structural only.

Four (4), ten (10) hour days may be worked at straight time during a week, Monday thru Thursday. Friday may be used as a make-up day.

NOTE - In order to use the '4 Day/10 Hour Work Schedule,' as your normal schedule, you must submit an 'Employer Registration for Use of 4 Day/10 Hour Work Schedule,' form PW30.1; and there must be a dispensation of hours in place on the project. If the PW30.1 is not submitted you may be liable for overtime payments for work over 8 hours per day.

SUPPLEMENTAL BENEFITS

Per hour worked

Journeyman \$ 19.23

OVERTIME PAY

See (B, E, E2, Q) on OVERTIME PAGE

HOLIDAY

Paid: See (1) on HOLIDAY PAGE

Overtime: See (5, 6) on HOLIDAY PAGE

Note: Any holiday which occurs on Sunday shall be observed the following Monday.

REGISTERED APPRENTICES

Wages per hour

750 hr terms at the following percentage of Journeyman's wage

1st	2nd	3rd	4th	5th	6th	7th	8th
55%	60%	65%	70%	75%	80%	85%	90%

Supplemental Benefits per hour worked

0-500 Hours	\$ 11.48
All others	\$ 19.23

12-2b.8

Mason - Heavy&Highway

01/01/2019

JOB DESCRIPTION Mason - Heavy&Highway

DISTRICT 12

ENTIRE COUNTIES

Albany, Cayuga, Clinton, Columbia, Essex, Franklin, Fulton, Greene, Hamilton, Herkimer, Jefferson, Lewis, Madison, Montgomery, Oneida, Oswego, Rensselaer, Saratoga, Schenectady, Schoharie, St. Lawrence, Warren, Washington

PARTIAL COUNTIES

Onondaga: For Heavy & Highway Cement Mason or Plaster Work in Onondaga County, refer to Mason-Heavy&Highway tag 1-2h/h on.

WAGES

Per hour
 07/01/2018
 Mason &
 Bricklayer \$37.23

Additional \$1.00 per hour for work on any swing scaffold or staging suspended by means of ropes or cables.

SUPPLEMENTAL BENEFITS

Per hour worked

Journeyman
 \$ 19.51

OVERTIME PAY

See (B, E, E2, Q) on OVERTIME PAGE

HOLIDAY

Paid: See (1) on HOLIDAY PAGE
 Overtime: See (5, 6) on HOLIDAY PAGE

Note: If a holiday falls on Sunday, the Monday following shall constitute the day of the legal holiday.

REGISTERED APPRENTICES

Wages per hour

750 HR TERMS at the following percent of Journeyman's wage

1st	2nd	3rd	4th	5th	6th	7th	8th
55%	60%	65%	70%	75%	80%	85%	90%

Supplemental Benefits per hour worked

\$ 19.51

12-2hh.1

Millwright

01/01/2019

JOB DESCRIPTION Millwright

DISTRICT 2

ENTIRE COUNTIES

Clinton, Essex, Franklin, Hamilton, Jefferson, Lewis, Oneida, Onondaga, Oswego, St. Lawrence, Warren, Washington

WAGES

Per hour:	07/01/2018	05/01/2019	07/01/2019 Additional	07/01/2020 Additional
Building	\$ 28.39	\$ 28.39	\$ 1.25	\$ 1.25
Heavy & Highway*	N/A	30.39	1.25	1.25

*Effective 5/1/19, all Heavy and Highway Millwright construction will be paid at the rate indicated above.

NOTE ADDITIONAL PREMIUMS PAID FOR THE FOLLOWING WORK LISTED BELOW (amount subject to any overtime premiums):

- Certified Welders shall receive \$1.75 per hour in addition to the current Millwright's rate provided he/she is directed to perform certified welding.
- If a work site has been declared a hazardous site by the Owner and the use of protective gear (including, as a minimum, air purifying canister-type chemical respirators) are required, then that employee shall receive a \$1.50 premium per hour.
- An employee performing the work of a machinist shall receive \$2.00 per hour in addition to the current Millwright's rate. For the purposes of this premium to apply, a "machinist" is a person who uses a lathe, Bridgeport, milling machine or similar type of tool to make or modify parts.
- When performing work underground at 500 feet and below, the employee shall receive an additional \$0.25. This amount will increase to \$0.50 on 7/1/2019 and to \$1.00 on 7/1/2020

SUPPLEMENTAL BENEFITS

Per hour:

Journeyman \$ 22.25 \$22.25

OVERTIME PAY

See (B, E, *E2, Q) on OVERTIME PAGE

*Note - Saturday may be used as a make-up day and worked at the straight time rate of pay during a work week when conditions such as weather, power failure, fire, or natural disaster prevent the performance of work on a regular scheduled work day.

HOLIDAY

Paid: See (1) on HOLIDAY PAGE
 Overtime: See (5, 6) on HOLIDAY PAGE

Note: Any holiday that falls on Sunday shall be observed the following Monday. Any holiday that falls on Saturday shall be observed the preceding Friday.

REGISTERED APPRENTICES

Wages per hour:

(1)year terms at the following percentage of journeyman's rate.

1st	2nd	3rd	4th
60%	70%	80%	90%

Supplemental Benefits per hour:

Apprentices:

1st term	\$ 10.25
2nd term	18.65
3rd term	19.85
4th term	21.05

2-1163.2

Operating Engineer - Building

01/01/2019

JOB DESCRIPTION Operating Engineer - Building

DISTRICT 1

ENTIRE COUNTIES

Albany, Clinton, Columbia, Essex, Franklin, Fulton, Greene, Hamilton, Herkimer, Montgomery, Otsego, Rensselaer, Saratoga, Schenectady, Schoharie, Warren, Washington

PARTIAL COUNTIES

Dutchess: Defined as north of the northern boundary line of City of Poughkeepsie then due east to Route 115 to Bedelt Road then east along Bedelt Road to VanWagner Road then north along VanWagner Road to Bower Road then east along Bower Road to Rte. 44 east to Route 343 then along Route 343 east to the northern boundary of Town of Dover Plains and east along the northern boundary of Town of Dover Plains to Connecticut.

WAGES

CLASS A1:

Crane, hydraulic cranes, tower crane, locomotive crane, piledriver, cableway, derricks,whirlies, dragline, boom trucks over 5 tons.

CLASS A:

Shovel, all Excavators (including rubber tire full swing), Gradalls, power road grader, all CMI equipment, front-end rubber tire loader, tractor-mounted drill (quarry master), mucking machine, concrete central mix plant, concrete pump, belcrete system, automated asphalt concrete plant, and tractor road paver, boom trucks 5 tons and under, maintenance engineer, self-contained crawler drill-hydraulic rock drill.

CLASS B:

Backhoes (rubber tired backhoe/loader combination), bulldozer, pushcat, tractor, traxcavator, scraper, LeTourneau grader, form fine grader, self-propelled soil compactor (fill roller), asphalt roller, blacktop spreader, power brooms, sweepers, trenching machine, Barber Green loader, side booms, hydro hammer, concrete spreader, concrete finishing machine, one drum hoist, power hoisting (single drum), hoist two drum or more, three drum engine, power hoisting (two drum and over), two drum and swinging engine, three drum swinging engine, hod hoist, A-L frame winches, core and well drillers (one drum), post hole digger, model CHB Vibro-Tamp or similar machine, batch bin and plant operator, dinky locomotive, skid steer loader, track excavator 5/8 cubic yard or smaller, front end rubber tired loader under four cubic yards, vacuum machine (mounted or towed).

CLASS C:

Fork lift, high lift, all terrain fork lift: or similar, oiler, fireman and heavy-duty greaser, boilers and steam generators, pump, vibrator, motor mixer, air compressor, dust collector, welding machine, well point, mechanical heater, generators, temporary light plants, electric submersible pumps 4" and over, murphy type diesel generator, conveyor, elevators, concrete mixer, beltcrete power pack (belcrete system), seeding, and mulching machines, pumps.

* In the event that equipment listed above is operated by robotic control, the classification covering the operation will be the same as if manually operated.

WAGES per hour

	07/01/2018
Class # A1	\$ 43.79
Class # A	43.30
Class # B	42.28
Class # C	39.38

Additional \$0.50 per hr for Tower Cranes.

Additional \$1.25 per hr for Cranes with Boom length & jib 150ft. and over.

Additional \$2.25 per hr for Cranes with Boom length & jib 200ft. and over.

Additional \$2.00 per hr over B rate for Nuclear Leader work.
Additional \$0.40 per hr for tunnel or excavation of shaft 40' or more deep.
Additional \$2.50 per hour if work requires Personal Protective Equipment for hazardous waste site activities with a level C or over rating.

SUPPLEMENTAL BENEFITS

Per hour

Journeyman \$ 25.90

OVERTIME PAY

See (B, E, Q) on OVERTIME PAGE

HOLIDAY

Paid: See (1) on HOLIDAY PAGE

Overtime: See (5, 6) on HOLIDAY PAGE

Note: If a holiday falls on Sunday, it will be celebrated on Monday. If the holiday falls on Saturday, it will be celebrated on Friday.

Employees who work a Saturday holiday shall be paid double time plus the holiday pay.

REGISTERED APPRENTICES

Wages per hour

1000 hours terms at the following percentage of Journeyman's wage Class B

1st	2nd	3rd	4th
60%	70%	80%	90%

Supplemental Benefits per hour worked

07/01/2018

All terms \$ 21.20

1-158 Alb

Operating Engineer - Heavy&Highway

01/01/2019

JOB DESCRIPTION Operating Engineer - Heavy&Highway

DISTRICT 1

ENTIRE COUNTIES

Albany, Broome, Chenango, Clinton, Columbia, Essex, Franklin, Fulton, Greene, Hamilton, Herkimer, Montgomery, Otsego, Rensselaer, Saratoga, Schenectady, Schoharie, Tioga, Warren, Washington

PARTIAL COUNTIES

Dutchess: Defined as north of the northern boundary line of City of Poughkeepsie then due east to Route 115 to Bedelt Road then east along Bedelt Road to VanWagner Road then north along VanWagner Road to Bower Road then east along Bower Road to Rte. 44 east to Route 343 then along Route 343 east to the northern boundary of Town of Dover Plains and east along the northern boundary of Town of Dover Plains to Connecticut.

WAGES

CLASSIFICATION A:

Asphalt Curb Machine (Self Propelled, Slipform), Asphalt Paver, Automated Concrete Spreader (CMI Type), Automatic Fine Grader, Backhoe (Except Tractor Mounted, Rubber Tired), Backhoe Excavator Full Swing (CAT 212 or similar type), Back Filling Machine, Belt Placer (CMI Type), Blacktop Plant (Automated), Boom truck, Cableway, Caisson Auger, Central Mix Concrete Plant (Automated), Concrete Curb Machine (Self Propelled, Slipform), Concrete Pump, Crane, Cherry Picker, Derricks (steel erection), Dragline, Overhead Crane (Gantry or Straddle type), Pile Driver, Truck Crane, Directional Drilling Machine, Dredge, Dual Drum Paver, Excavator (All PurposeHydraulically Operated) (Gradall or Similar), Front End Loader (4 cu. yd. and Over), Head Tower (Sauerman or Equal), Hoist (Two or Three Drum), Holland Loader, Maintenance Engineer, Mine Hoist, Mucking Machine or Mole, Pavement Breaker(SP) Wertgen; PB-4 and similar type, Power Grader, Profiler (over 105 H.P.), Quad 9, Quarry Master (or equivalent), Scraper, Shovel, Side Boom, Slip Form Paver (If a second man is needed, he shall be an Oiler), Tractor Drawn BeltType Loader, Truck or Trailer Mounted Log Chipper (Self Feeder), Tug Operator (Manned Rented Equipment Excluded), Tunnel Shovel

CLASSIFICATION B:

Backhoe (Tractor Mounted, Rubber Tired), Bituminous Recycler Machine, Bituminous Spreader and Mixer, Blacktop Plant (NonAutomated), Blast or Rotary Drill (Truck or Tractor Mounted), Boring Machine, Cage Hoist, Central Mix Plant [(NonAutomated) and All Concrete Batching Plants], Concrete Paver (Over 16S), Crawler Drill (Self-contained), Crusher, Diesel Power Unit, Drill Rigs, Tractor Mounted, Front End Loader (Under 4 cu. yd.), Greaseman/Lubrication Engineer, HiPressure Boiler (15 lbs. and over), Hoist (One Drum), Hydro-Axe, Kolman Plant Loader and Similar Type Loaders (If Employer requires another man to clean the screen or to maintain the equipment, he shall be an Oiler), L.C.M. Work Boat Operator, Locomotive, Material handling knuckle boom, Mixer (for stabilized base selfpropelled), Monorail Machine, Plant Engineer, Profiler (105 H.P. and under), Pug Mill, Pump Crete, Ready Mix Concrete Plant, Refrigeration Equipment (for soil stabilization), Road Widener, Roller (all above subgrade), Sea Mule, Self-contained Ride-on Rock Drill(Excluding Air-Track Type Drill), Skidder, Tractor with Dozer and/or Pusher, Trencher, Tugger Hoist, Vacuum machine (mounted or towed), Vermeer saw (ride on, any size or type), Welder

CLASSIFICATION C:

A Frame Winch Hoist on Truck, Articulated Heavy Hauler, Aggregate Plant, Asphalt or Concrete Grooving Machine (ride on), Ballast Regulator(Ride-on), Boiler (used in conjunction with production), Bituminous Heater (self-propelled), Boat (powered), Cement and Bin Operator, Concrete Pavement Spreader and Finisher Concrete Paver or Mixer (16' and under), Concrete Saw (self-propelled), Conveyor, Deck Hand, Directional Drill Machine Locator, Drill (Core and Well), Farm Tractor with accessories, Fine Grade Machine, Fireman, Fork Lift, Form Tamper, Grout Pump, Gunit Machine, Hammers (Hydraulic self-propelled), Hydra-Spiker (ride-on), Hydraulic Pump (jacking system), Hydro-Blaster (Water), Mulching Machine, Oiler, Parapet Concrete or Pavement Grinder, Post Hole Digger and Post Driver, Power Broom (towed), Power Heaterman, Power Sweeper, Revinus Widener, Roller (Grade and Fill), Scarifier (ride-on), Shell Winder, Skid steer loader (Bobcat or similar), Span-Saw (ride-on), Steam Cleaner, Tamper (ride-on), Tie Extractor (ride-on), Tie Handler (ride-on), Tie Inserter (ride-on), Tie Spacer (ride-on), Tire Repair, Track Liner (ride-on), Tractor, Tractor (with towed accessories), Vibratory Compactor, Vibro Tamp, Well Point, and the following hands-off equipment: Compressors, Dust Collectors, Generators, Pumps, Welding Machines, Light Plants and Heaters

- Note for all above classifications of Operating Engineer - In the event that equipment listed above is operated by robotic control, the classification covering the operation will be the same as if manually operated.

WAGES per hour

	07/01/2018
Master Mechanic	\$ 45.08
Class A*	43.47
Class B	42.56
Class C	39.99

Additional \$2.00 per hour for All Employees who work a single irregular work shift starting from 5:00 PM to 1:00 AM that is mandated by the Contracting Agency.

Additional \$2.50 per hr. for hazardous waste removal work on State and/or Federally designated waste site which require employees to wear Level C or above forms of personal protection.

(*) Premiums for CRANES is based upon Class A rates with the following premiums:

- Additional \$4.00 per hr for Tower Cranes, including self erecting.
- Additional \$3.00 per hr for Lattice Boom Cranes and all other cranes with a manufacturers rating of fifty (50) tons and over.
- Additional \$2.00 per hr for all Hydraulic Cranes and Derricks with a manufacturer's rating of 49 ton and below, including boom trucks.

Four (4), ten (10) hour days may be worked at straight time during a week, Monday thru Thursday. Friday may be used as a make-up day.

NOTE - In order to use the '4 Day/10 Hour Work schedule', as your normal schedule, you must submit an 'Employer Registration for Use of 4 Day/10 Hour Work Schedule,' form PW30.1; and there must be a dispensation of hours in place on the project. If the PW30.1 is not submitted you may be liable for overtime payments for work over 8 hours per day.

SUPPLEMENTAL BENEFITS

Per hour

Journeyman \$ 26.10

OVERTIME PAY

See (B, E, Q) on OVERTIME PAGE

HOLIDAY

Paid: See (5, 6) on HOLIDAY PAGE

Overtime: See (5, 6) on HOLIDAY PAGE

Note: If the holiday falls on Sunday, it will be celebrated on Monday. If the holiday falls on a Saturday, it will be celebrated on Saturday.

REGISTERED APPRENTICES

Wages per hour

1000 hours terms at the following percentage of Journeyman's wage Class B

1st	2nd	3rd	4th
60%	70%	80%	90%

Supplemental Benefits per hour worked

	07/01/2018
All Terms	\$ 21.50

1-158H/H Alb

Operating Engineer - Marine Dredging

01/01/2019

JOB DESCRIPTION Operating Engineer - Marine Dredging
ENTIRE COUNTIES

DISTRICT 4

Albany, Bronx, Cayuga, Chautauqua, Clinton, Columbia, Dutchess, Erie, Essex, Franklin, Greene, Jefferson, Kings, Monroe, Nassau, New York, Niagara, Orange, Orleans, Oswego, Putnam, Queens, Rensselaer, Richmond, Rockland, St. Lawrence, Suffolk, Ulster, Washington, Wayne, Westchester

WAGES

These wages do not apply to Operating Engineers on land based construction projects. For those projects, please see the Operating Engineer Heavy/Highway Rates. The wage rates below for barge mounted cranes and other equipment are only for marine dredging work in navigable waters found in the counties listed above.

Per Hour:

DREDGING OPERATIONS 07/01/2018
 CLASS A
 Operator, Leverman, \$ 38.18
 Lead Dredgeman

CLASS A1 To conform to Operating Engineer
 Dozer, Front Loader Prevailing Wage in locality where work
 Operator is being performed including benefits.

CLASS B \$ 33.02
 Barge Operator
 Spider/Spill
 Tug Operator(over1000hp),
 OperatorII, Fill Placer,
 Derrick Operator, Engineer,
 Chief Mate, Electrician,
 Chief Welder,
 Maintenance Engineer

Certified Welder, \$ 31.09
 Boat Operator(licensed)

CLASS C \$ 30.24
 Drag Barge Operator,
 Steward, Mate,
 Assistant Fill Placer,

Welder (please add)\$ 0.06

Boat Operator \$ 29.26

CLASS D \$ 24.30
 Shoreman, Deckhand,
 Rodman, Scowman, Cook,
 Messman, Porter/Janitor

Oiler(please add)\$ 0.09

SUPPLEMENTAL BENEFITS

Per Hour:

THE FOLLOWING SUPPLEMENTAL BENEFITS APPLY TO ALL CATEGORIES

All Classes A & B 07/01/2018
 \$11.23 plus 8%
 of straight time
 wage, Overtime hours
 add \$ 0.63

All Class C \$10.93 plus 8%
 of straight time
 wage, Overtime hours
 add \$ 0.48

All Class D \$10.63 plus 8%
 of straight time

wage, Overtime hours
add \$ 0.33

OVERTIME PAY

See (B, F, R) on OVERTIME PAGE

HOLIDAY

Paid: See (1) on HOLIDAY PAGE
Overtime: See (5, 6, 8, 15, 26) on HOLIDAY PAGE

4-25a-MarDredge

Operating Engineer - Survey Crew

01/01/2019

JOB DESCRIPTION Operating Engineer - Survey Crew

DISTRICT 12

ENTIRE COUNTIES

Albany, Allegany, Broome, Cayuga, Chemung, Chenango, Clinton, Columbia, Cortland, Essex, Franklin, Fulton, Greene, Hamilton, Herkimer, Jefferson, Lewis, Livingston, Madison, Monroe, Montgomery, Niagara, Oneida, Onondaga, Ontario, Oswego, Otsego, Rensselaer, Saratoga, Schenectady, Schoharie, Schuyler, Seneca, St. Lawrence, Steuben, Tioga, Tompkins, Warren, Washington, Wayne, Yates

PARTIAL COUNTIES

Dutchess: The northern portion of the county from the northern boundary line of the City of Poughkeepsie, north.
Genesee: Only the portion of the county that lies east of a line down the center of Route 98 to include all area that lies within the City of Batavia.

WAGES

These rates apply to Building, Tunnel and Heavy Highway.

Per hour:

SURVEY CLASSIFICATIONS:

Party Chief - One who directs a survey party.
Instrument Person - One who operates the surveying instruments.
Rod Person - One who holds the rods and assists the Instrument Person.

07/01/2018

Party Chief \$ 40.45
Instrument Person 38.17
Rod Person 26.48

Additional \$3.00/hr. for Tunnel Work
Additional \$2.50/hr. for Hazardous Work Site

SUPPLEMENTAL BENEFITS

Per hour worked:

Journeyman \$ 25.75

OVERTIME PAY

See (B, E, P, T) on OVERTIME PAGE

HOLIDAY

Paid: See (5, 6) on HOLIDAY PAGE
Overtime: See (5, 6) on HOLIDAY PAGE

REGISTERED APPRENTICES

WAGES: 1000 hour terms based on the Percentage of Rod Persons Wage:

07/01/2018

0-1000 60%
1001-2000 70%
2001-3000 80%

SUPPLEMENTAL BENEFIT per hour worked:

0-1000 \$ 15.45
1001-2000 \$ 18.03
2001-3000 \$ 20.60

12-158-545 D.H.H.

Operating Engineer - Survey Crew - Consulting Engineer

01/01/2019

JOB DESCRIPTION Operating Engineer - Survey Crew - Consulting Engineer

DISTRICT 12

ENTIRE COUNTIES

Albany, Allegany, Broome, Cayuga, Chemung, Chenango, Clinton, Columbia, Cortland, Essex, Franklin, Fulton, Greene, Hamilton, Herkimer, Jefferson, Lewis, Livingston, Madison, Monroe, Montgomery, Niagara, Oneida, Onondaga, Ontario, Oswego, Otsego, Rensselaer, Saratoga, Schenectady, Schoharie, Schuyler, Seneca, St. Lawrence, Steuben, Tioga, Tompkins, Warren, Washington, Wayne, Yates

PARTIAL COUNTIES

Dutchess: The northern portion of the county from the northern boundary line of the City of Poughkeepsie, north.
Genesee: Only the portion of the county that lies east of a line down the center of Route 98 to include all area that lies within the City of Batavia.

WAGES

These rates apply to feasibility and preliminary design surveying, line and grade surveying for inspection or supervision of construction when performed under a Consulting Engineer Agreement.

Per hour:

SURVEY CLASSIFICATIONS:

- Party Chief - One who directs a survey party.
- Instrument Person - One who operates the surveying instruments.
- Rod Person - One who holds the rods and assists the Instrument Person.

07/01/2018

Party Chief	\$ 41.40
Instrument Person	38.02
Rod Person	28.12

Additional \$3.00/hr. for Tunnel Work.
Additional \$2.50/hr. for EPA or DEC certified toxic or hazardous waste work.

SUPPLEMENTAL BENEFITS

Per hour worked:

Journeyman	\$ 24.90
------------	----------

OVERTIME PAY

See (B, E, P, T) on OVERTIME PAGE

HOLIDAY

Paid: See (5, 6) on HOLIDAY PAGE
Overtime: See (5, 6) on HOLIDAY PAGE

REGISTERED APPRENTICES

WAGES: 1000 hour terms based on percentage of Rod Persons Wage:

07/01/2018

0-1000	60%
1001-2000	70%
2001-3000	80%

SUPPLEMENTAL BENIFIT per hour worked:

0-1000	\$ 16.82
1001-2000	\$ 19.63
2001-3000	\$ 22.45

12-158-545 DCE

Operating Engineer - Tunnel

01/01/2019

JOB DESCRIPTION Operating Engineer - Tunnel

DISTRICT 7

ENTIRE COUNTIES

Albany, Allegany, Broome, Cayuga, Chemung, Chenango, Clinton, Columbia, Cortland, Essex, Franklin, Fulton, Greene, Hamilton, Herkimer, Jefferson, Lewis, Livingston, Madison, Monroe, Montgomery, Oneida, Onondaga, Ontario, Oswego, Otsego, Rensselaer, Saratoga, Schenectady, Schoharie, Schuyler, Seneca, St. Lawrence, Steuben, Tioga, Tompkins, Warren, Washington, Wayne, Yates

PARTIAL COUNTIES

Dutchess: Northern part of Dutchess to the northern boundary line of the City of Poughkeepsie then due east to Route 115 to Bedelt Road then east along Bedelt Road to VanWagner Road then north along VanWagner Road to Bower Road then east along Bower Road to Rte. 44 east to Rte. 343 then along Rte. 343 east to the northern boundary of the Town of Dover Plains and east along the northern boundary of the Town of Dover Plains to Connecticut.

Genesee: Only that portion of the county that lies east of a line drawn down the center of Route 98 and the entirety of the City of Batavia.

WAGES

CLASS A: Automatic Concrete Spreader (CMI Type); Automatic Fine Grader; Backhoe (except tractor mounted, rubber tired); Belt Placer (CMI Type); Blacktop Plant (automated); Cableway; Caisson Auger; Central Mix Concrete Plant (automated); Concrete Curb Machine (self-propelled slipform); Concrete Pump (8" or over); Dredge; Dual Drum Paver; Excavator; Front End Loader (4 cu. yd & over); Gradall; Head Tower (Sauerman or Equal); Hoist (shaft); Hoist (two or three Drum); Log Chipper/Loader (self-feeder); Maintenance Engineer (shaft and tunnel); any Mechanical Shaft Drill; Mine Hoist; Mining Machine (Mole and similar types); Mucking Machine or Mole; Overhead Crane (Gantry or Straddle Type); Pile Driver; Power Grader; Remote Controlled Mole or Tunnel Machine; Scraper; Shovel; Side Boom; Slip Form Paver (If a second man is needed, they shall be an Oiler); Tripper/Maintenance Engineer (shaft & tunnel); Tractor Drawn Belt-Type Loader; Tug Operator (manned rented equipment excluded); Tunnel Shovel

CLASS B: Automated Central Mix Concrete Plant; Backhoe (topside); Backhoe (track mounted, rubber tired); Backhoe (topside); Bituminous Spreader and Mixer, Blacktop Plant (non-automated); Blast or Rotary Drill (truck or tractor mounted); Boring Machine; Cage Hoist; Central Mix Plant (non-automated); all Concrete Batching Plants; Compressors (4 or less exceeding 2,000 c.f.m. combined capacity); Concrete Pump; Crusher; Diesel Power Unit; Drill Rigs (tractor mounted); Front End Loader (under 4 cu. yd.); Grayco Epoxy Machine; Hoist (One Drum); Hoist (2 or 3 drum topside); Knuckle Boom material handler; Kolman Plant Loader & similar type Loaders (if employer requires another person to clean the screen or to maintain the equipment, they shall be an Oiler); L.C.M. Work Boat Operator; Locomotive; Maintenance Engineer (topside); Maintenance Grease Man; Mixer (for stabilized base-self propelled); Monorail Machine; Plant Engineer; Personnel Hoist; Pump Crete; Ready Mix Concrete Plant; Refrigeration Equipment (for soil stabilization); Road Widener; Roller (all above sub-grade); Sea Mule; Shotcrete Machine; Shovel (topside); Tractor with Dozer and/or Pusher; Trencher; Tugger Hoist; Tunnel Locomotive; Welder; Winch; Winch Cat

CLASS C: A Frame Truck; All Terrain Telescoping Material Handler; Ballast Regulator (ride-on); Compressors (4 not to exceed 2,000 c.f.m. combined capacity; or 3 or less with more than 1200 c.f.m. but not to exceed 2,000 c.f.m.); Compressors ((any size, but subject to other provisions for compressors), Dust Collectors, Generators, Pumps, Welding Machines, Light Plants (4 or any type combination)); Concrete Pavement Spreaders and Finishers; Conveyor; Drill (core); Drill (well); Electric Pump used in conjunction with Well Point System; Farm Tractor with Accessories; Fine Grade Machine; Fork Lift; Grout Pump (over 5 cu. ft.); Gunite Machine; Hammers (hydraulic-self-propelled); Hydra-Spiker (ride-on); Hydra-Blaster (water); Hydro-Blaster; Motorized Form Carrier; Post Hole Digger and Post Driver; Power Sweeper; Roller grade & fill); Scarifer (ride-on); Span-Saw (ride-on); Submersible Electric Pump (when used in lieu of well points); Tamper (ride-on); Tie-Extractor (ride-on), Tie Handler (ride-on), Tie Inserter (ride-on), Tie Spacer (ride-on); Track Liner (ride-on); Tractor with towed accessories; Vibratory Compactor; Vibro Tamp, Well Point

CLASS D: Aggregate Plant; Cement & Bin Operator; Compressors (3 or less not to exceed 1,200 c.f.m. combined capacity); Compressors ((any size, but subject to other provisions for compressors), Dust Collectors, Generators, Pumps, Welding Machines, Light Plants (3 or less or any type or combination)); Concrete Saw (self-propelled); Form Tamper; Greaseman; Hydraulic Pump (jacking system); Junior Engineer; Light Plants; Mulching Machine; Oiler; Parapet Concrete or Pavement Grinder; Power Broom (towed); Power Heaterman (when used for production); Revinus Widener; Shell Winder; Steam Cleaner; Tractor

WAGES per hour:

07/01/2018

Master Mechanic	\$ 46.65
CLASS A	44.24
CLASS B	43.02
CLASS C	40.23
CLASS D	37.22

Additional \$5.00 per hour for Hazardous Waste Work on a state or federally designated hazardous waste site where the Operating Engineer is in direct contact with hazardous material and when personal protective equipment is required for respiratory, skin and eye protection. Fringe benefits will be paid at the hourly wage premium.

CRANES:

Crane 1: All cranes, including self-erecting to be paid \$4.00 per hour over the Class A rate.

Crane 2: All Lattice Boom Cranes and all cranes with a manufacturer's rating of fifty (50) ton and over to be paid \$3.00 per hour over Class A rate.

Crane 3: All hydraulic cranes and derricks with a manufacturer's rating of forty nine (49) ton and below, including boom trucks, to be paid \$2.00 per hour over Class A rate.

Crane 1	\$ 48.24
Crane 2	47.24
Crane 3	46.24

SUPPLEMENTAL BENEFITS

Per hour:

\$ 28.40

OVERTIME PAY

See (B, B2, E, Q, X) on OVERTIME PAGE

HOLIDAY

Paid: See (5, 6) on HOLIDAY PAGE

Overtime: See (5, 6) on HOLIDAY PAGE

If a holiday falls on Sunday, it shall be observed on Monday.

REGISTERED APPRENTICES

WAGES:(1000) hours terms at the following percentage of Journeyman's wage.

1st term	60% of Class B
2nd term	65% of Class B
3rd term	70% of Class B
4th term	75% of Class B

SUPPLEMENTAL BENEFITS per hour paid: Same as Journeyman

7-158-832TL.

Painter **01/01/2019**

JOB DESCRIPTION Painter

DISTRICT 1

ENTIRE COUNTIES

Albany, Essex, Fulton, Hamilton, Montgomery, Rensselaer, Saratoga, Schenectady, Schoharie, Warren, Washington

WAGES

Per hour	07/01/2018	05/01/2019 Additional
Painter\Wallcover	\$ 28.59	\$1.40
Drywall Finishers	28.59	1.40
Spray Rate	28.59	1.40
Structural Steel*	29.59	1.40
Lead Abatement	29.59	1.40
Lead Abatement on Structural Steel	30.59	1.40

(*)Employees working on objects with the use of swing stage, boatswain chair, pick and cables only will be paid at Structural Steel rate.

Bridge Painter

See Bridge Painter rates for the following work:

All Bridges and Tanks

SUPPLEMENTAL BENEFITS

Per hour

Journeyman \$ 15.90

OVERTIME PAY

See (B, E2, H) on OVERTIME PAGE

HOLIDAY

Paid: See (1) on HOLIDAY PAGE

Overtime: See (5, 6) on HOLIDAY PAGE

Note: If the holiday falls on Sunday, it shall be observed on Monday.

REGISTERED APPRENTICES

Wages per hour

1000 hour terms at the following percentage of Journeyman's base wage

1st	2nd	3rd	4th	5th	6th
45%	50%	60%	70%	80%	90%

Supplemental Benefits per hour worked

All Terms \$ 15.90

1-201-P

Painter - Bridge & Structural Steel **01/01/2019**

JOB DESCRIPTION Painter - Bridge & Structural Steel

DISTRICT 8

ENTIRE COUNTIES

Albany, Bronx, Clinton, Columbia, Dutchess, Essex, Franklin, Fulton, Greene, Hamilton, Kings, Montgomery, Nassau, New York, Orange, Putnam, Queens, Rensselaer, Richmond, Rockland, Saratoga, Schenectady, Schoharie, Suffolk, Sullivan, Ulster, Warren, Washington, Westchester

WAGES

Per Hour:

STEEL:

Bridge Painting:	07/01/2018	10/01/2018
	\$ 49.50	\$ 49.50
	+ 6.38*	+ 6.38*

ADDITIONAL \$6.00 per hour for POWER TOOL/SPRAY, whether straight time or overtime.

NOTE: All premium wages are to be calculated on base rate per hour only.

* For the period of May 1st to November 15th, this amount is payable up to 40 hours. For the period of Nov 16th to April 30th, this amount is payable up to 50 hours. EXCEPTION: First and last week of employment, and for the weeks of Memorial Day, Independence Day and Labor Day, where the amount is paid for the actual number of hours worked (no cap).

NOTE: Generally, for Bridge Painting Contracts, ALL WORKERS on and off the bridge (including Flagmen) are to be paid Painter"s Rate; the contract must be ONLY for Bridge Painting.

SUPPLEMENTAL BENEFITS

Per Hour:

Journeyworker:	07/01/2018	10/01/2018
	\$ 8.25	\$ 9.50
	+ 24.35*	+ 26.05*

* For the period of May 1st to November 15th, this amount is payable up to 40 hours. For the period of Nov 16th to April 30th, this amount is payable up to 50 hours. EXCEPTION: First and last week of employment, and for the weeks of Memorial Day, Independence Day and Labor Day, where the amount is paid for the actual number of hours worked (no cap).

OVERTIME PAY

See (A, F, R) on OVERTIME PAGE

HOLIDAY

Paid: See (1) on HOLIDAY PAGE
 Overtime: See (4, 6) on HOLIDAY PAGE

REGISTERED APPRENTICES

Wage - Per hour:

Apprentices: (1) year terms

	07/01/2018	10/01/2018
1st year	\$ 22.65	\$ 23.13
2nd year	33.98	34.73
3rd year	45.30	46.30

Supplemental Benefits - Per hour:

1st year	\$ 12.76	\$ 13.44
2nd year	19.14	20.16
3rd year	25.52	26.88

8-DC-9/806/155-BrSS

Painter - Line Striping

01/01/2019

JOB DESCRIPTION Painter - Line Striping

DISTRICT 8

ENTIRE COUNTIES

Albany, Bronx, Clinton, Columbia, Dutchess, Essex, Franklin, Fulton, Greene, Hamilton, Kings, Montgomery, Nassau, New York, Orange, Putnam, Queens, Rensselaer, Richmond, Rockland, Saratoga, Schenectady, Schoharie, Suffolk, Sullivan, Ulster, Warren, Washington, Westchester

WAGES

Per hour:

Painter (Striping-Highway):	07/01/2018
Striping-Machine Operator*	\$ 29.93

Linerman Thermoplastic \$ 36.06

Note: * Includes but is not limited to: Positioning of cones and directing of traffic using hand held devices. Excludes the Driver/Operator of equipment used in the maintenance and protection of traffic safety.

Four (4), ten (10) hour days may be worked at straight time during a week, Monday thru Thursday. Friday may be used as a make-up day.

NOTE - In order to use the '4 Day/10 Hour Work Schedule,' as your normal schedule, you must submit an 'Employer Registration for Use of 4 Day/10 Hour Work Schedule,' form PW30.1; and there must be a dispensation of hours in place on the project. If the PW30.1 is not submitted you may be liable for overtime payments for work over 8 hours per day.

SUPPLEMENTAL BENEFITS

Per hour paid: 07/01/2018
Journeyworker:

Striping-Machine operator \$ 7.44
Linerman Thermoplastic \$ 7.44

OVERTIME PAY

See (B, B2, E2, F, S) on OVERTIME PAGE

HOLIDAY

Paid: See (5, 20) on HOLIDAY PAGE
Overtime: See (5, 20) on HOLIDAY PAGE

REGISTERED APPRENTICES

One (1) year terms at the following wage rates:

07/01/2018

1st term \$ 11.97
2nd term 17.96
3rd term 23.94

Supplemental Benefits per hour:

1st term \$ 7.44
2nd term 7.44
3rd term 7.44

8-1456-LS

Painter - Metal Polisher

01/01/2019

JOB DESCRIPTION Painter - Metal Polisher

DISTRICT 8

ENTIRE COUNTIES

Albany, Allegany, Bronx, Broome, Cattaraugus, Cayuga, Chautauqua, Chemung, Chenango, Clinton, Columbia, Cortland, Delaware, Dutchess, Erie, Essex, Franklin, Fulton, Genesee, Greene, Hamilton, Herkimer, Jefferson, Kings, Lewis, Livingston, Madison, Monroe, Montgomery, Nassau, New York, Niagara, Oneida, Onondaga, Ontario, Orange, Orleans, Oswego, Otsego, Putnam, Queens, Rensselaer, Richmond, Rockland, Saratoga, Schenectady, Schoharie, Schuylar, Seneca, St. Lawrence, Steuben, Suffolk, Sullivan, Tioga, Tompkins, Ulster, Warren, Washington, Wayne, Westchester, Wyoming, Yates

WAGES

07/01/2018

Metal Polisher \$ 30.58
Metal Polisher* 31.53
Metal Polisher** 34.08

*Note: Applies on New Construction & complete renovation

** Note: Applies when working on scaffolds over 34 feet.

SUPPLEMENTAL BENEFITS

Per Hour: 07/01/2018

Journeyworker:
All classification \$ 7.72

OVERTIME PAY

See (B, E, P, T) on OVERTIME PAGE

HOLIDAY

Paid: See (5, 6, 11, 15, 16, 25, 26) on HOLIDAY PAGE
Overtime: See (5, 6, 9, 11, 15, 16, 25, 26) on HOLIDAY PAGE

REGISTERED APPRENTICES

Wages per hour:

One (1) year term at the following wage rates:

	07/01/2018	01/01/2019
1st year	\$ 13.00	\$ 15.00
2nd year	13.00	15.00
3rd year	15.75	15.75
1st year*	\$ 15.39	\$ 17.39
2nd year*	15.44	17.44
3rd year*	16.29	18.29
1st year**	\$ 17.50	19.50
2nd year**	17.50	19.50
3rd year**	18.25	20.25

*Note: Applies on New Construction & complete renovation

** Note: Applies when working on scaffolds over 34 feet.

Supplemental benefits:

Per hour:

	07/01/2018	01/01/2019
1st year	\$ 5.52	\$ 5.52
2nd year	5.52	5.52
3rd year	5.52	5.52

8-8A/28A-MP

Plumber

01/01/2019

JOB DESCRIPTION Plumber

DISTRICT 1

ENTIRE COUNTIES

Essex

PARTIAL COUNTIES

Franklin: Entire County except for the Village of Hogansburg and the St. Regis Indian Reservation.

Hamilton: The Townships of Long Lake and Indian Lake

WAGES

Per hour

	07/01/2018	05/01/2019
Plumber & Steamfitter	\$ 38.00	+\$1.65

SUPPLEMENTAL BENEFITS

Per hour

Journeyman	\$ 19.60 +10.23*
------------	---------------------

* This portion of the benefit is subject to the SAME PREMIUM as shown for overtime and applicable to paid Holidays.

OVERTIME PAY

See (B, E, Q) on OVERTIME PAGE

HOLIDAY

Paid: See (22) on HOLIDAY PAGE

Overtime: See (5, 6, 16, 23) on HOLIDAY PAGE

Note: Whenever a Holiday falls on a Saturday, the preceding day, Friday, shall be observed as the Holiday. If a Holiday falls on a Sunday, the following day, Monday shall be observed as the Holiday.

REGISTERED APPRENTICES

Wages per hour

One year terms at the following percentage of Journeyman's wage

1st yr	50%
2nd yr	60%
3rd yr	70%
4th yr	80%
5th yr	90%

Supplemental Benefits per hour worked

1st yr	\$ 17.03 + 5.12*
2nd yr	17.54 + 6.14*
3rd yr	18.06 + 7.16*
4th yr	18.57 + 8.18*
5th yr	19.09 + 9.21*

* This portion of the benefit is subject to the SAME PREMIUM as shown for overtime.
 * This portion per hour paid.

1-773EF-SF

Roofer **01/01/2019**

JOB DESCRIPTION Roofer

DISTRICT 1

ENTIRE COUNTIES

Albany, Clinton, Columbia, Essex, Fulton, Greene, Hamilton, Montgomery, Rensselaer, Saratoga, Schenectady, Warren, Washington

WAGES

Per hour 07/01/2018

Roofer/Waterproofer	\$ 30.05
Asphalt Cold Process	30.55
Fluid Applied Roof	30.55
Pitch & Asbestos	32.05

Shift Work:

On government mandated shift work starting after 12:00pm and before 4:00am workers shall be paid \$4.00 additional per hour

SUPPLEMENTAL BENEFITS

Per hour

Journeyman \$ 19.27

OVERTIME PAY

See (B, E, Q) on OVERTIME PAGE.

HOLIDAY

Paid: See (1) on HOLIDAY PAGE
 Overtime: See (5, 6) on HOLIDAY PAGE

Note: When any Holiday falls on Saturday, the Friday before such Holiday shall be recognized as the legal Holiday. When a Holiday falls on Sunday, it shall be observed the following Monday.

REGISTERED APPRENTICES

Wages per hour

Apprentice terms at the following per cent of the Roofer/Waterproofer rate. For Pitch & Asbestos work, an additional \$2.00 must be paid in wages. For Asphalt Cold Process work and Fluid Applied Roof coating, an additional \$0.50 must be paid in the wages.

1st Term	58%
1500 hrs.	
2nd Term	74%
1 yr. and 1500 hrs.	
3rd Term	90%
1 yr. and 1050 hrs.	

Supplemental Benefits per hour worked

1st Term	\$ 17.69
2nd Term	18.12
3rd Term	18.60

1-241

Sheetmetal Worker **01/01/2019**

JOB DESCRIPTION Sheetmetal Worker

DISTRICT 1

ENTIRE COUNTIES

Albany, Clinton, Columbia, Essex, Franklin, Fulton, Greene, Hamilton, Montgomery, Rensselaer, Saratoga, Schenectady, Schoharie, Warren, Washington

WAGES

Per hour
 07/01/2018
 Sheetmetal Worker \$32.55

All work requiring HAZWOPER Training additional \$1.00 per hour

SUPPLEMENTAL BENEFITS

Per hour
 Journeyman \$31.95

OVERTIME PAY

See (B,E,E5,Q) on OVERTIME PAGE

HOLIDAY

Paid: See (1) on HOLIDAY PAGE
 Overtime: See (5, 6) on HOLIDAY PAGE

When any holiday falls on Saturday, the Friday before such holiday shall be recognized as the legal holiday. Any holiday falling on Sunday, the following Monday shall be recognized as the legal holiday.

REGISTERED APPRENTICES

Wages per hour

6 Month Terms at the following rate:

1st term	\$18.05
2nd term	\$19.56
3rd term	\$20.32
4th term	\$21.08
5th term	\$19.96
6th term	\$20.96
7th term	\$22.61
8th term	\$24.27
9th term	\$25.93
10th term	\$27.58

Supplemental Benefits per hour worked

1st term	\$19.45
2nd term	20.03
3rd term	20.32
4th term	20.74
5th term	26.48
6th term	26.91
7th term	27.63
8th term	28.35
9th term	29.07
10th term	29.79

Sprinkler Fitter 01/01/2019

JOB DESCRIPTION Sprinkler Fitter

DISTRICT 1

ENTIRE COUNTIES

Allegany, Broome, Cattaraugus, Cayuga, Chautauqua, Chemung, Chenango, Clinton, Columbia, Cortland, Delaware, Erie, Essex, Franklin, Fulton, Genesee, Greene, Hamilton, Herkimer, Jefferson, Lewis, Livingston, Madison, Monroe, Montgomery, Niagara, Oneida, Onondaga, Ontario, Orleans, Oswego, Otsego, Schoharie, Schuyler, Seneca, St. Lawrence, Steuben, Tioga, Tompkins, Washington, Wayne, Wyoming, Yates

WAGES

Per hour	07/01/2018	01/01/2019
Sprinkler Fitter	\$ 34.91	34.91

SUPPLEMENTAL BENEFITS

Per hour		
Journeyman	\$ 23.14	23.69

OVERTIME PAY

See (B, E, Q) on OVERTIME PAGE

HOLIDAY

Paid: See (1) on HOLIDAY PAGE
 Overtime: See (5, 6) on HOLIDAY PAGE

Note: When a holiday falls on Sunday, the following Monday shall be considered a holiday and all work performed on either day shall be at the double time rate. When a holiday falls on Saturday, the preceding Friday shall be considered a holiday and all work performed on either day shall be at the double time rate.

REGISTERED APPRENTICES

Wages per hour

For Apprentices HIRED ON OR AFTER 04/01/2010:

One Half Year terms at the following percentage of journeyman's wage.

1st	2nd	3rd	4th	5th	6th	7th	8th	9th	10th
45%	50%	55%	60%	65%	70%	75%	80%	85%	90%

Supplemental Benefits per hour worked

1st	2nd	3rd	4th	5th	6th	7th	8th	9th	10th
\$ 8.93	\$ 8.97	\$ 17.09	\$ 17.13	\$ 17.68	\$ 17.72	\$ 17.77	\$ 17.81	\$ 17.86	\$ 17.90

For Apprentices HIRED ON OR AFTER 04/01/2013:

One Half Year terms at the following percentage of journeyman's wage.

1st	2nd	3rd	4th	5th	6th	7th	8th	9th	10th
45%	50%	55%	60%	65%	70%	75%	80%	85%	90%

Supplemental Benefits per hour worked

1st	2nd	3rd	4th	5th	6th	7th	8th	9th	10th
\$ 8.27	\$ 8.27	\$ 17.24	\$ 17.24	\$ 17.49	\$ 17.49	\$ 17.49	\$ 17.49	\$ 17.49	\$ 17.49

1-669

Teamster - Building

01/01/2019

JOB DESCRIPTION Teamster - Building

DISTRICT 7

ENTIRE COUNTIES

Clinton, Essex, Franklin, Jefferson, St. Lawrence

PARTIAL COUNTIES

Lewis: Only the Townships of Croghan, Denmark, Diana, New Bremen, Harrisburg, Montague, Osceola and Pinckney.

Oswego: Only the Towns of Boylston, Redfield, and Sandy Creek.

Warren: Only the Townships of Hague, Horicon, Chester and Johnsburg.

WAGES

GROUP # 1: Fuel Trucks, Fork Lift (Warehouse & Storage Area Only), Bus, Warehouse, Yardman, Truck Helper, Pickups, Panel Truck, Flatbody Material Trucks (straight Jobs), Single axle Dump Trucks, Dumpsters, Material Checkers & Receivers, Greasers, Tiremen, Mechanic Helpers and Parts Chasers.

GROUP # 2: Tandems, Mechanics & Batch Trucks.

GROUP # 3: Semi Trailers, Low Boys, Asphalt Distributor Trucks, and Agitator Mixer Truck, Dump Crete Type Vehicles and 3 axle Dump trucks.

GROUP # 4: Asbestos Removal, Special earth moving Euclid type or similar off highway equip.(non self load.) Articulated and all-track dump trucks.

Wages per hour

07/01/2018

Building:

Group #1	\$ 23.58
Group #2	24.58
Group #3	24.68
Group #4	23.84

SUPPLEMENTAL BENEFITS

Per hour:

All groups \$ 21.51

OVERTIME PAY

See (B, E, Q) on OVERTIME PAGE

HOLIDAY

Paid: See (1) on HOLIDAY PAGE
Overtime: See (5, 6) on HOLIDAY PAGE

7-687B

Teamster - Heavy&Highway

01/01/2019

JOB DESCRIPTION Teamster - Heavy&Highway

DISTRICT 7

ENTIRE COUNTIES

Clinton, Essex, Franklin, Jefferson, St. Lawrence

PARTIAL COUNTIES

Lewis: Only the Townships of Croghan, Denmark, Diana, New Bremen, Harrisburg, Montague, Osceola and Pinckney.
Oswego: Only the Towns of Boylston, Redfield, and Sandy Creek.
Warren: Only the Townships of Hague, Horicon, Chester and Johnsbury.

WAGES

GROUP 1: Warehousemen, Yardmen, Truck Helpers, Pickups, Panel Trucks, Flatboy Material Trucks(straight jobs), Single Axle Dump Trucks, Dumpsters, Material Checkers and Receivers, Greasers, Truck Tirmen, Mechanics Helpers and Parts Chasers. Fork Lift (storage & warehouse areas only) Tandems and Batch Trucks, Mechanics, Dispatcher. Semi-Trailers, Low-boy Trucks, Asphalt Distributor Trucks, and Agitator, Mixer Trucks and dumpcrete type vehicles, Truck Mechanic, Fuel Truck.

GROUP 2: Specialized Earth Moving Equipment, Euclid type, or similar off-highway where not self-loading, Straddle (Ross) Carrier, and self-contained concrete mobile truck. Off-highway Tandem Back-Dump, Twin Engine Equipment and Double-Hitched Equipment where not self-loading.

Per hour:

07/01/2018

Heavy/Highway:

Group #1 \$ 25.82
Group #2 26.04

Additional \$1.50 per hour for hazardous waste removal work on a City, County, and/or Federal Designated waste site and regulations require employee to use or wear respiratory protection.

For work bid on or after April 1, 1982 there shall be a 12 month carryover of the negotiated rate in effect at the time of the bid.

SUPPLEMENTAL BENEFITS

Per hour:

All classes \$ 23.52

OVERTIME PAY

See (B, E, Q) on OVERTIME PAGE

HOLIDAY

Paid: See (5, 6) on HOLIDAY PAGE
Overtime: See (5, 6) on HOLIDAY PAGE

NOTE: If a holiday falls on a Sunday, it will be celebrated on Monday.

7-687

Welder

01/01/2019

JOB DESCRIPTION Welder

DISTRICT 1

ENTIRE COUNTIES

Albany, Allegany, Bronx, Broome, Cattaraugus, Cayuga, Chautauqua, Chemung, Chenango, Clinton, Columbia, Cortland, Delaware, Dutchess, Erie, Essex, Franklin, Fulton, Genesee, Greene, Hamilton, Herkimer, Jefferson, Kings, Lewis, Livingston, Madison, Monroe, Montgomery, Nassau, New York, Niagara, Oneida, Onondaga, Ontario, Orange, Orleans, Oswego, Otsego, Putnam, Queens, Rensselaer, Richmond, Rockland, Saratoga, Schenectady, Schoharie, Schuyler, Seneca, St. Lawrence, Steuben, Suffolk, Sullivan, Tioga, Tompkins, Ulster, Warren, Washington, Wayne, Westchester, Wyoming, Yates

WAGES

Per hour 07/01/2018

Welder: To be paid the same rate of the mechanic performing the work.*

*EXCEPTION: If a specific welder certification is required, then the 'Certified Welder' rate in that trade tag will be paid.

OVERTIME PAY

HOLIDAY

1-As Per Trade

Overtime Codes

Following is an explanation of the code(s) listed in the OVERTIME section of each classification contained in the attached schedule. Additional requirements may also be listed in the HOLIDAY section.

NOTE: Supplemental Benefits are 'Per hour worked' (for each hour worked) unless otherwise noted

- (AA) Time and one half of the hourly rate after 7 and one half hours per day
- (A) Time and one half of the hourly rate after 7 hours per day
- (B) Time and one half of the hourly rate after 8 hours per day
- (B1) Time and one half of the hourly rate for the 9th & 10th hours week days and the 1st 8 hours on Saturday.
Double the hourly rate for all additional hours
- (B2) Time and one half of the hourly rate after 40 hours per week
- (C) Double the hourly rate after 7 hours per day
- (C1) Double the hourly rate after 7 and one half hours per day
- (D) Double the hourly rate after 8 hours per day
- (D1) Double the hourly rate after 9 hours per day
- (E) Time and one half of the hourly rate on Saturday
- (E1) Time and one half 1st 4 hours on Saturday; Double the hourly rate all additional Saturday hours
- (E2) Saturday may be used as a make-up day at straight time when a day is lost during that week due to inclement weather
- (E3) Between November 1st and March 3rd Saturday may be used as a make-up day at straight time when a day is lost during that week due to inclement weather, provided a given employee has worked between 16 and 32 hours that week
- (E4) Saturday and Sunday may be used as a make-up day at straight time when a day is lost during that week due to inclement weather
- (E5) Double time after 8 hours on Saturdays
- (F) Time and one half of the hourly rate on Saturday and Sunday
- (G) Time and one half of the hourly rate on Saturday and Holidays
- (H) Time and one half of the hourly rate on Saturday, Sunday, and Holidays
- (I) Time and one half of the hourly rate on Sunday
- (J) Time and one half of the hourly rate on Sunday and Holidays
- (K) Time and one half of the hourly rate on Holidays
- (L) Double the hourly rate on Saturday
- (M) Double the hourly rate on Saturday and Sunday
- (N) Double the hourly rate on Saturday and Holidays
- (O) Double the hourly rate on Saturday, Sunday, and Holidays
- (P) Double the hourly rate on Sunday
- (Q) Double the hourly rate on Sunday and Holidays
- (R) Double the hourly rate on Holidays
- (S) Two and one half times the hourly rate for Holidays, if worked

- (S1) Two and one half times the hourly rate the first 8 hours on Sunday or Holidays One and one half times the hourly rate all additional hours.
- (T) Triple the hourly rate for Holidays, if worked
- (U) Four times the hourly rate for Holidays, if worked
- (V) Including benefits at SAME PREMIUM as shown for overtime
- (W) Time and one half for benefits on all overtime hours.
- (X) Benefits payable on Paid Holiday at straight time. If worked, additional benefit amount will be required for worked hours. (Refer to other codes listed.)

Holiday Codes

PAID Holidays:

Paid Holidays are days for which an eligible employee receives a regular day's pay, but is not required to perform work. If an employee works on a day listed as a paid holiday, this remuneration is in addition to payment of the required prevailing rate for the work actually performed.

OVERTIME Holiday Pay:

Overtime holiday pay is the premium pay that is required for work performed on specified holidays. It is only required where the employee actually performs work on such holidays. The applicable holidays are listed under HOLIDAYS: OVERTIME. The required rate of pay for these covered holidays can be found in the OVERTIME PAY section listings for each classification.

Following is an explanation of the code(s) listed in the HOLIDAY section of each classification contained in the attached schedule. The Holidays as listed below are to be paid at the wage rates at which the employee is normally classified.

- (1) None
- (2) Labor Day
- (3) Memorial Day and Labor Day
- (4) Memorial Day and July 4th
- (5) Memorial Day, July 4th, and Labor Day
- (6) New Year's, Thanksgiving, and Christmas
- (7) Lincoln's Birthday, Washington's Birthday, and Veterans Day
- (8) Good Friday
- (9) Lincoln's Birthday
- (10) Washington's Birthday
- (11) Columbus Day
- (12) Election Day
- (13) Presidential Election Day
- (14) 1/2 Day on Presidential Election Day
- (15) Veterans Day
- (16) Day after Thanksgiving
- (17) July 4th
- (18) 1/2 Day before Christmas
- (19) 1/2 Day before New Years
- (20) Thanksgiving
- (21) New Year's Day
- (22) Christmas
- (23) Day before Christmas
- (24) Day before New Year's
- (25) Presidents' Day
- (26) Martin Luther King, Jr. Day
- (27) Memorial Day
- (28) Easter Sunday



**New York State Department of Labor - Bureau of Public Work
State Office Building Campus
Building 12 - Room 130
Albany, New York 12240**

REQUEST FOR WAGE AND SUPPLEMENT INFORMATION

As Required by Articles 8 and 9 of the NYS Labor Law

Fax (518) 485-1870 or mail this form for new schedules or for determination for additional occupations.

This Form Must Be Typed

Submitted By:

(Check Only One)

Contracting Agency Architect or Engineering Firm Public Work District Office Date:

A. Public Work Contract to be let by: (Enter Data Pertaining to Contracting/Public Agency)

1. Name and complete address (Check if new or change)

Telephone: ()

Fax: ()

E-Mail:

2. NY State Units (see Item 5)

- | | |
|---|--|
| <input type="checkbox"/> 01 DOT | <input type="checkbox"/> 07 City |
| <input type="checkbox"/> 02 OGS | <input type="checkbox"/> 08 Local School District |
| <input type="checkbox"/> 03 Dormitory Authority | <input type="checkbox"/> 09 Special Local District, i.e.,
Fire, Sewer, Water District |
| <input type="checkbox"/> 04 State University
Construction Fund | <input type="checkbox"/> 10 Village |
| <input type="checkbox"/> 05 Mental Hygiene
Facilities Corp. | <input type="checkbox"/> 11 Town |
| <input type="checkbox"/> 06 OTHER N.Y. STATE UNIT | <input type="checkbox"/> 12 County |
| | <input type="checkbox"/> 13 Other Non-N.Y. State
(Describe) |

3. SEND REPLY TO check if new or change)
Name and complete address:

Telephone:()

Fax: ()

E-Mail:

4. SERVICE REQUIRED. Check appropriate box and provide project information.

New Schedule of Wages and Supplements.

APPROXIMATE BID DATE :

Additional Occupation and/or Redetermination

PRC NUMBER ISSUED PREVIOUSLY FOR
THIS PROJECT :

OFFICE USE ONLY

B. PROJECT PARTICULARS

5. Project Title _____

Description of Work _____

Contract Identification Number _____

Note: For NYS units, the OSC Contract No. _____

6. Location of Project:
Location on Site _____

Route No/Street Address _____

Village or City _____

Town _____

County _____

7. Nature of Project - Check One:

- 1. New Building
- 2. Addition to Existing Structure
- 3. Heavy and Highway Construction (New and Repair)
- 4. New Sewer or Waterline
- 5. Other New Construction (Explain)
- 6. Other Reconstruction, Maintenance, Repair or Alteration
- 7. Demolition
- 8. Building Service Contract

8. OCCUPATION FOR PROJECT :

- | | |
|--|---|
| <input type="checkbox"/> Construction (Building, Heavy
Highway/Sewer/Water) | <input type="checkbox"/> Guards, Watchmen |
| <input type="checkbox"/> Tunnel | <input type="checkbox"/> Janitors, Porters, Cleaners,
Elevator Operators |
| <input type="checkbox"/> Residential | <input type="checkbox"/> Moving furniture and
equipment |
| <input type="checkbox"/> Landscape Maintenance | <input type="checkbox"/> Trash and refuse removal |
| <input type="checkbox"/> Elevator maintenance | <input type="checkbox"/> Window cleaners |
| <input type="checkbox"/> Exterminators, Fumigators | <input type="checkbox"/> Other (Describe) |
| <input type="checkbox"/> Fire Safety Director, NYC Only | |

9. Has this project been reviewed for compliance with the Wicks Law involving separate bidding? YES NO

10. Name and Title of Requester

Signature



NEW YORK STATE DEPARTMENT OF LABOR
Bureau of Public Work - Debarment List

**LIST OF EMPLOYERS INELIGIBLE TO BID ON OR BE
AWARDED ANY PUBLIC WORK CONTRACT**

Under Article 8 and Article 9 of the NYS Labor Law, a contractor, sub-contractor and/or its successor shall be debarred and ineligible to submit a bid on or be awarded any public work or public building service contract/sub-contract with the state, any municipal corporation or public body for a period of five (5) years from the date of debarment when:

- Two (2) final determinations have been rendered within any consecutive six-year (6) period determining that such contractor, sub-contractor and/or its successor has WILLFULLY failed to pay the prevailing wage and/or supplements;
- One (1) final determination involves falsification of payroll records or the kickback of wages and/or supplements.

The agency issuing the determination and providing the information, is denoted under the heading 'Fiscal Officer'. DOL = New York State Department of Labor; NYC = New York City Comptroller's Office; AG = New York State Attorney General's Office; DA = County District Attorney's Office.

Debarment Database: To search for contractors, sub-contractors and/or their successors debarred from bidding or being awarded any public work contract or subcontract under NYS Labor Law Articles 8 and 9, or under NYS Workers' Compensation Law Section 141-b, access the database at this link: <https://applications.labor.ny.gov/EDList/searchPage.do>

For inquiries where WCB is listed as the "Agency", please call 1-866-546-9322

NYS DOL Bureau of Public Work Debarment List 01/17/2019

Article 8

AGENCY	Fiscal Officer	FEIN	EMPLOYER NAME	EMPLOYER DBA NAME	ADDRESS	DEBARMENT START DATE	DEBARMENT END DATE
DOL	DOL	****0996	A-1 CONSTRUCTION & RENOVATION INC		1973 81ST ST - SUITE A-5 BROOKLYN NY 11214	01/08/2015	01/08/2020
DOL	NYC		ABDUL KARIM		C/O NORTH AMERICAN IRON W 1560 DECATUR STREET RIDGEWOOD NY 11385	05/15/2015	05/15/2020
DOL	DOL	****8018	ACCURATE MECHANICAL LLC		9547 BUSTLETON AVENUE PHILADELPHIA PA 19115	02/05/2014	02/05/2019
DOL	DOL		ACCURATE MECHANICAL OF PHILADELPHIA LLC		9547 BUSTLETON AVENUE PHILADELPHIA PA 19115	02/05/2014	02/05/2019
DOL	DOL	****3344	ACT INC		6409 LAND O LAKES BLVD LAND O LAKES FL 34638	11/10/2015	11/10/2020
DOL	NYC		ADRIANA SELA	C/O COLONIAL ROOFING COMPANY INC	247 48TH STREET BROOKLYN NY 11220	02/05/2014	02/05/2019
DOL	DOL	****1687	ADVANCED SAFETY SPRINKLER INC		261 MILL ROAD P O BOX 296 EAST AURORA NY 14052	07/29/2015	07/29/2020
DOL	NYC	****6775	ADVENTURE MASONRY CORP.		1535 RICHMOND AVENUE STATEN ISLAND NY 10314	12/13/2017	12/13/2022
DOL	DOL		AJ TORCHIA		10153 ROBERTS RD SAUQUOIT NY 13456	08/09/2016	08/09/2021
DOL	DOL	****3344	ALL CATASTROPHE CONSTRUCTION TEAM INC	ACT INC	6409 LAND O LAKES BLVD LAND O LAKES FL 34638	11/10/2015	11/10/2020
DOL	DOL	****8740	ALLSTATE ENVIRONMENTAL CORP		C/O JOSE MONTAS 27 BUTLER PLACE YONKERS NY 10710	03/18/2011	03/19/2020
DOL	DOL		AMADEO J TORCHIA	TORCHIA'S HOME IMPROVEMENT	10153 ROBERTS RD SAUQUOIT NY 13456	08/09/2016	08/09/2021
DOL	DOL		ANGELO F COKER			12/04/2018	12/04/2023
DOL	NYC		ANISUL ISLAM		C/O RELIANCE GENERAL CONS 644 OCEAN PARKWAY BROOKLYN NY 11230	09/02/2015	09/02/2020
DOL	DOL	****7004	ANNEX CONTRACTING LTD		3005 WYNSUM AVENUE MERRICK NY 11566	08/18/2014	08/18/2019
DOL	DOL	****7004	ANNEX GENERAL CONTRACTING INC		3005 WYNSUM AVENUE MERRICK NY 11566	08/18/2014	08/18/2019
DOL	DA		ANTHONY CARDINALE		58-48 59TH STREET MASPETH NY 11378	05/16/2012	05/08/2020
DOL	DOL		ANTHONY J MINGARELLI JR		C/O T & T CONCRETE INC 2560 HAMBURG TURNPIKELACKAWANNA NY 14218	07/08/2015	07/08/2020
DOL	DOL		ANTHONY PERGOLA		3 WEST MAIN ST/SUITE 208 ELMSFORD NY 10323	01/23/2017	01/23/2022
DOL	DOL		ANTONIO ESTIVEZ		442 ARMONK RD MOUNT KISCO NY 10549	06/12/2018	06/12/2023
DOL	DOL	****3020	APCO CONTRACTING CORP		24 SOUTH MARYLAND AVENUE PORT WASHINGTON NY 11050	09/24/2012	09/02/2020
DOL	DOL	****3219	APOLLO CONSTRUCTION SERVICES CORP	APOLLO PAINTING CO	157 TIBBETTS ROAD YONKERS NY 10705	03/12/2014	03/12/2019
DOL	DOL		APOLLO PAINTING CO		157 TIBBETTS ROAD YONKERS NY 10705	03/12/2014	03/12/2019
DOL	DOL	****3295	APOLLO PAINTING CORP		3 ALAN B SHEPARD PLACE YONKERS NY 10705	03/12/2014	03/12/2019
DOL	NYC	****8403	AQUA JET PAINTING CORP		10 VIKING DRIVE WEST ISLIP NY 11795	04/16/2014	04/16/2019
DOL	NYC	****9232	ARKAY CONSTRUCTION INC		102-104 GREYLOCK AVENUE BELLEVILLE NJ 07109	07/15/2015	07/15/2020
DOL	NYC	****4779	ASTORIA GENERAL CONTRACTING CORP		35-34 31ST STREET LONG ISLAND CITY NY 11106	09/02/2015	09/02/2020
DOL	NYC	****7217	ASTRO COMMUNICATIONS OF NY CORP		79 ALEXANDER AVE- STE 36A BRONX NY 10454	10/30/2015	10/30/2020
DOL	NYC	****6046	ATLANTIC SUN CONSTRUCTION CORP		58-46 59TH AVENUE MASPETH NY 11378	05/08/2015	05/08/2020
DOL	NYC	****6683	ATLAS RESTORATION CORP.		35-12 19TH AVENUE ASTORIA NY 11105	08/02/2017	08/02/2022
DOL	NYC		AUDLEY O'BRIEN		1273 NORTH AVENUE/#1 CP NEW ROCHELLE NY 10804	04/07/2015	04/07/2020

NYSDOL Bureau of Public Work Debarment List 01/17/2019

Article 8

DOL	NYC	****2591	AVI 212 INC.		260 CROPSY AVENUE APT 11BROOKLYN NY 11214	10/30/2018	10/30/2023
DOL	DOL		AVIS R HILL		3510 HICKORY WALK LANE ELLENWOOD GA 32094	01/22/2015	01/22/2020
DOL	AG		AVTAR SINGH		116-24 127TH STREET SOUTH OZONE PARK NY 11420	12/22/2015	12/22/2020
DOL	AG		BALDEV SINGH		116-24 127TH STREET SOUTH OZONE PARK NY 11420	12/22/2015	12/22/2020
DOL	DOL		BARBARA CASSIDY		7 BLENIS PLACE VALHALLA NY 10595	04/02/2015	04/02/2020
DOL	DOL		BARRY KINNEY		6409 LAND O LAKES BLVD LAND O LAKES FL 34638	11/10/2015	11/10/2020
DOL	NYC	****3915	BEACON RESTORATION INC		SUITE B-8 782 PELHAM PARKWAY SOUTHBRONX NY 10462	04/21/2016	04/21/2021
DOL	DOL		BIAGIO CANTISANI			06/12/2018	06/12/2023
DOL	DOL	****8551	BRANDY'S MASONRY		216 WESTBROOK STREET P O BOX 304SAYRE PA 18840	08/09/2016	08/09/2021
DOL	NYC	****6555	BROOKLYN WELDING CORP		1273 NORTH AVENUE/ #1 CP NEW ROCHELLE NY 10804	04/07/2015	04/07/2020
DOL	DOL	****1449	BRRESTORATION NY INC		140 ARCADIA AVENUE OSWEGO NY 13126	09/12/2016	09/12/2021
DOL	DOL		BRUCE MORSEY		C/O KENT HOLLOW SIDING LL 29A BRIDGE STREETNEW MILFORD CT 06776	01/15/2016	01/15/2021
DOL	DOL		BRUCE P. NASH JR.		5841 BUTTERNUT ROAD EAST SYRACUSE NY 13057	09/12/2018	09/12/2023
DOL	DOL	****6156	C & J LANDSCAPING & MAINTENANCE INC		520 PINE HILL ROAD CHESTER NY 10940	06/23/2014	06/23/2019
DOL	DOL	****8809	C.B.E. CONTRACTING CORPORATION		310 MCGUINNESS BLVD GREENPOINT NY 11222	03/07/2017	03/07/2022
DOL	DOL	****9383	C.C. PAVING AND EXCAVATING, INC.		2610 SOUTH SALINA ST SUITE 12SYRACUSE NY 13205	12/04/2018	12/04/2023
DOL	DOL		CANTISANI & ASSOCIATES LTD		442 ARMONK RD MOUNT KISCO NY 10549	06/12/2018	06/12/2023
DOL	DOL		CANTISANI HOLDING LLC			06/12/2018	06/12/2023
DOL	DOL		CARIBBEAN POOLS		C/O DOUGLAS L MALARKEY 64 VICTORIA DRIVEBINGHAMTON NY 13904	02/04/2016	02/04/2021
DOL	DOL	****3812	CARMODY "2" INC			06/12/2018	06/12/2023
DOL	DOL	****1143	CARMODY BUILDING CORP	CARMODY CONTRACTIN G AND CARMODY CONTRACTIN G CORP.	442 ARMONK RD MOUNT KISCO NY 10549	06/12/2018	06/12/2023
DOL	DOL		CARMODY CONCRETE CORPORATION			06/12/2018	06/12/2023
DOL	DOL		CARMODY ENTERPRISES, LTD.		442 ARMONK RD MOUNT KISCO NY 10549	06/12/2018	06/12/2023
DOL	DOL		CARMODY INC		442 ARMONK RD MOUNT KISCO NY 10549	06/12/2018	06/12/2023
DOL	DOL	****3812	CARMODY INDUSTRIES INC			06/12/2018	06/12/2023
DOL	DOL		CARMODY MAINTENANCE CORPORATION		442 ARMONK RD MOUNT KISCO NY 10549	06/12/2018	06/12/2023
DOL	DOL		CARMODY MASONRY CORP		442 ARMONK RD MOUNT KISCO NY 10549	06/12/2018	06/12/2023
DOL	NYC	****9172	CASSIDY EXCAVATING INC		14 RAILROAD AVENUE VALHALLA NY 10595	05/15/2014	04/02/2020
DOL	DOL	****6745	CATSKILL FENCE INSTALLATIONS INC		5445 ROUTE 32 CATSKILL NY 12414	08/22/2014	08/22/2019
DOL	DOL	****8809	CBE CONTRACTING CORP		142 EAST MARKET STREET LONG BEACH NY 11561	03/07/2017	03/07/2022
DOL	AG		CESAR J. AGUDELO		81-06 34TH AVENUE APT. 6EJACKSON HEIGHTS NY 11372	02/07/2018	02/07/2023
DOL	DOL	****7655	CHAMPION CONSTRUCTION SERVICES CORP		2131 SCHENECTADY AVENUE BROOKLYN NY 11234	11/18/2015	11/18/2020
DOL	NYC		CHARLES CASSIDY JR		14 RAILROAD AVENUE VALHALLA NY 10595	05/15/2014	04/02/2020
DOL	DOL		CHARLES ZIMMER JR		216 WESTBROOK STREET P O BOX 304SAYRE PA 18840	08/09/2016	08/09/2021

NYS DOL Bureau of Public Work Debarment List 01/17/2019

Article 8

DOL	DOL		CHRISTINE J HEARNE		C/O CJ-HEARNE CONSTRUCTIO 131 PONCE DE LEON AVE NEATLANTA GA 30308	12/01/2015	12/01/2020
DOL	DOL		CHRISTOPHER J MAINI		19 CAITLIN AVE JAMESTOWN NY 14701	09/17/2018	09/17/2023
DOL	DOL	****3360	CITY LIMITS GROUP INC		2279 HOLLERS AVENUE BRONX NY 10475	01/07/2014	06/23/2019
DOL	DOL	****0671	CJ-HEARNE CONSTRUCTION CO		SUITE 204 131 PONCE DE LEON AVENUEATLANTA GA 30308	12/01/2015	12/01/2020
DOL	NYC	****2905	COLONIAL ROOFING COMPANY INC		247 48TH STREET BROOKLYN NY 11220	02/05/2014	02/05/2019
DOL	DOL	****2703	CONKLIN'S TECH- MECHANICAL INC		5 PARKER AVENUE POUGHKEEPSIE NY 12601	03/25/2014	03/25/2019
DOL	DOL	****1927	CONSTRUCTION PARTS WAREHOUSE, INC.	CPW	5841 BUTTERNUT ROAD EAST SYRACUSE NY 13057	09/12/2018	09/12/2023
DOL	NYC	****4468	CRAFT CONTRACTING GROUP INC		3256 BRUNER AVENUE BRONX NY 10469	07/29/2014	07/29/2019
DOL	NYC	****8507	CRAFT FENCE INC		3256 BRUNER AVENUE BRONX NY 10469	07/29/2014	07/29/2019
DOL	NYC	****2164	CREATIVE TRUCKING INC		58-83 54TH STREET MASPETH NY 11378	02/26/2016	02/26/2021
DOL	DOL	****7761	D L MALARKEY CONSTRUCTION		64 VICTORIA DRIVE BINGHAMTON NY 13904	02/04/2016	02/04/2021
DOL	DOL	****7888	D L MALARKEY CONSTRUCTION INC		64 VICTORIA DRIVE BINGHAMTON NY 13904	02/04/2016	02/04/2021
DOL	DOL	****5629	DAKA PLUMBING AND HEATING LLC		2561 ROUTE 55 POUGHQUAG NY 12570	02/19/2016	02/19/2021
DOL	DOL		DANICA IVANOSKI		61 WILLETT ST. PASSAIC NJ 07503	10/26/2016	10/26/2021
DOL	DOL		DARIAN L COKER		2610 SOUTH SALINA ST SUITE 2CSYRACUSE NY 13205	12/04/2018	12/04/2023
DOL	DOL		DARYL T RIEKS		C/O RIEKS CONTRACTING LLC 4804 GAHWILER ROADAUBURN NY 13021	05/01/2015	05/01/2020
DOL	NYC	****7707	DASSLE CONTRACTING INC		213-37 39TH AVE/SUITE 120 BAYSIDE NY 11360	05/08/2015	05/08/2020
DOL	DOL		DAVID MARTINEZ		C/O EMPIRE TILE INC 6 TREMONT COURTHUNTINGTON STATION NY 11746	03/08/2016	03/08/2021
DOL	NYC		DAWN AVILA AKA DAWN BECHTOLD		1ST FLOOR STORE FRONT 88-10 LITTLE NECK PARKWAYFLORAL PARK NY 11001	06/24/2014	06/24/2019
DOL	NYC		DAWN BECHTOLD AKA DAWN AVILA		1ST FLOOR STORE FRONT 88-10 LITTLE NECK PARKWAYFLORAL PARK NY 11001	06/24/2014	06/24/2019
DOL	DOL		DEBBIE STURDEVANT		29 MAPLEWOOD DRIVE BINGHAMTON NY 13901	02/21/2017	02/21/2022
DOL	AG		DEBRA MARTINEZ		31 BAY ST BROOKLYN NY 11231	03/28/2018	03/28/2023
DOL	DOL		DEDA GAZIVODAN		C/O DAKA PLUMBING AND H 2561 ROUTE 55POUGHQUAG NY 12570	02/19/2016	02/19/2021
DOL	DOL		DENNIS SCHWANDTNER		C/O YES SERVICE AND REPAI 145 LODGE AVEHUNTINGTON STATION NY 11476	08/09/2016	08/09/2021
DOL	DOL		DF CONTRACTORS OF ROCHESTER, INC.		1835 DAANSEN RD. PALMYRA NY 14522	05/16/2017	05/16/2022
DOL	DOL		DF CONTRACTORS, INC.		1835 DAANSEN RD. PALMYRA NY 14522	05/16/2017	05/16/2022
DOL	DOL	****9252	DI BERNARDO TILE AND MARBLE CO INC		15 WALKER WAY ALBANY NY 12205	03/21/2014	03/21/2019
DOL	NYC		DIMITRIOS KOUTSOUKOS		C/O ASTORIA GENERAL CONTR 35-34 31ST STREETLONG ISLAND CITY NY 11106	09/02/2015	09/02/2020
DOL	NYC		DIMITRIOS TSOUMAS		35-12 19TH AVENUE ASTORIA NY 11105	08/02/2017	08/02/2022
DOL	DOL	****3242	DONALD R. FORSAY	DF LAWN SERVICE	1835 DAANSEN RD. PALMYRA NY 14522	05/16/2017	05/16/2022
DOL	DOL		DONALD R. FORSAY		1835 DAANSEN RD. PALMYRA NY 14522	05/16/2017	05/16/2022

NYS DOL Bureau of Public Work Debarment List 01/17/2019

Article 8

DOL	DOL		DORIS SKODA		C/O APCO CONTRACTING CORP 24 SOUTH MARYLAND AVENUE PORT WASHINGTON NY 11050	09/24/2012	09/02/2020
DOL	NYC	****7404	DOSANJH CONSTRUCTION CORP		9439 212TH STREET QUEENS VILLAGE NY 11428	02/25/2016	02/25/2021
DOL	DOL		DOUGLAS L MALARKEY	MALARKEY CONSTRUCTION	64 VICTORIA DRIVE B INGHAMTON NY 13904	02/04/2016	02/04/2021
DOL	DOL	****6982	DUFOUR GROUP INC	DUFOUR MASONRY	353 WEST 56TH STREET #7M NEW YORK NY 10019	06/10/2014	06/10/2019
DOL	DOL		DUFOUR MASONRY		353 WEST 56TH ST #7M NEW YORK NY 10019	06/10/2014	06/10/2019
DOL	DOL		DUFOUR MASONRY & RESTORATION INC		123 ALBANY NY	06/10/2014	06/10/2019
DOL	DOL		E C WEBB		6409 LAND O LAKES BLVD LAND O LAKES FL 34638	11/10/2015	11/10/2020
DOL	DOL		EARL L WILSON	WILSON BROTHER DRYWALL CONTRACTORS	36 ABERSOLD STREET ROCHESTER NY 14621	08/31/2015	08/31/2020
DOL	DOL		EAST COAST PAVING		2238 BAKER RD GILLET PA 16923	03/12/2018	03/12/2023
DOL	NYC		EDWARD MENKEN		C/O AQUA JET PAINTING 10 VIKING DRIVE WEST ISLIP NY 11795	04/16/2014	04/16/2019
DOL	NYC	****0900	EF PRO CONTRACTING INC		147 BROOME AVENUE ATLANTIC BEACH NY 11509	03/03/2014	03/03/2019
DOL	NYC		EFSTRATIOS BERNARDIS		23-73 48TH STREET LONG ISLAND CITY NY 11103	04/24/2014	04/24/2019
DOL	DOL	****0780	EMES HEATING & PLUMBING CONTR		5 EMES LANE MONSEY NY 10952	01/20/2002	01/20/3002
DOL	AG		EMILIO FRANZA		90 JUNIUS STREET BROOKLYN NY 11212	01/23/2014	01/23/2019
DOL	DOL	****3270	EMPIRE TILE INC		6 TREMONT COURT HUNTINGTON STATION NY 11746	03/08/2016	03/08/2021
DOL	DOL	****7403	F & B PAINTING CONTRACTING INC		2 PARKVIEW AVENUE HARRISON NY 10604	09/26/2016	09/26/2021
DOL	DOL		F KALAFATIS		2279 HOLLERS AVENUE BRONX NY 10475	01/07/2014	06/23/2019
DOL	DOL		FAY MATTHEW		C/O CHAMPION CONSTRUCTION 2131 SCHENECTADY AVENUE BROOKLYN NY 11234	11/18/2015	11/18/2020
DOL	DOL		FAZIA GINA ALI-MOHAMMED	C/O CHAMPION CONSTRUCTION	2131 SCHENECTADY AVENUE BROOKLYN NY 11234	11/18/2015	11/18/2020
DOL	DOL		FRAN MICELI		2279 HOLLERS AVENUE BRONX NY 10475	01/07/2014	06/23/2019
DOL	DOL		FRANCES KALAFATIS		2279 HOLLERS AVENUE BRONX NY 10475	01/07/2014	06/23/2019
DOL	DOL		FRANCES KALAFATIS-MICELI		2279 HOLLERS AVENUE BRONX NY 10475	01/07/2014	06/23/2019
DOL	DOL		FRANK BENEDETTO		19 CATLIN AVE JAMESTOWN NY 14701	09/17/2018	09/17/2023
DOL	DOL		FRANK BENEDETTO		C/O F & B PAINTING CONTRA 2 PARKVIEW AVENUE HARRISON NY 10604	09/26/2016	09/26/2021
DOL	DOL	****4722	FRANK BENEDETTO AND CHRISTOPHER J MAINI	B & M CONCRETE	19 CAITLIN AVE JAMESTOWN NY 14701	09/17/2018	09/17/2023
DOL	DOL		FRANK DEMARTINO		101-61 99TH STREET OZONE PARK NY 11416	02/15/2017	02/15/2022
DOL	DOL		FRANK DEMARTINO		101-61 99TH STREET OZONE PARK NY 11416	02/15/2017	02/15/2022
DOL	DOL		FRANK J MERCANDO		134 MURRAY AVENUE YONKERS NY 10704	12/11/2009	02/03/2019
DOL	DOL	****2724	FRESH START PAINTING CORP		157 TIBBETS ROAD YONKERS NY 10705	03/12/2014	03/12/2019
DOL	DOL		G FUCCI CONSTRUCTION SERVICES		3 ALAN B SHEPARD PLACE YONKERS NY 10705	03/12/2014	03/12/2019
DOL	DOL	****6767	G FUCCI PAINTING INC		C/O SPIEGEL & UTRERA 1 MAIDEN LANE - 5TH FL NEW YORK NY 10038	03/12/2014	03/12/2019
DOL	DOL	****4546	GAF PAINTING LLC		157 TIBBETS ROAD YONKERS NY 10705	03/12/2014	03/12/2019

NYS DOL Bureau of Public Work Debarment List 01/17/2019

Article 8

DOL	DOL		GALINDA ROTENBERG		C/O GMDV TRANS INC 67-48 182ND STREET FRESH MEADOWS NY 11365	06/24/2016	06/24/2021
DOL	DOL		GARDEN STATE PAINTING		157 TIBBETTS ROAD YONKERS NY 10705	03/12/2014	03/12/2019
DOL	DOL		GEOFF CORLETT		415 FLAGGER AVE #302STUART FL 34994	10/31/2018	10/31/2023
DOL	DOL		GEORGE DI BERNARDO		C/O DI BERNARDO TILE 15 WALKER WAY ALBANY NY 12205	03/21/2014	03/21/2019
DOL	DA		GEORGE LUCEY		150 KINGS STREET BROOKLYN NY 11231	01/19/1998	01/19/2998
DOL	DOL	****5674	GMDV TRANS INC		67-48 182ND STREET FRESH MEADOWS NY 11365	06/24/2016	06/24/2021
DOL	NYC		GREAT ESTATE CONSTRUCTION, INC.		327 STAGG ST BROOKLYN NY 11206	10/10/2017	10/10/2022
DOL	DOL		GREGORY A FUCCI		C/O PAF PAINTING SERVICES 157 TIBBETTS ROAD YONKERS NY 10705	03/12/2014	03/12/2019
DOL	DOL		GREGORY FUCCI JR		C/O APOLLO CONSTRUCTION 157 TIBBETTS ROAD YONKERS NY 10705	03/12/2014	03/12/2019
DOL	DOL		GREGORY S. OLSON		P.O BOX 100 200 LATTA BROOK PARKHORSEHEADS NY 14845	03/08/2018	03/08/2023
DOL	NYC	****0346	H N H CONTRACTORS CORP		4558 BROADWAY # 6 NEW YORK NY 10040	08/04/2014	08/04/2019
DOL	NYC		HAMEEDUL HASAN		240 HOME STREET TEANECK NJ 07666	08/04/2014	08/04/2019
DOL	NYC		HARMEL SINGH		15 CLINTON LANE HICKSVILLE NY 11801	02/25/2016	02/25/2021
DOL	NYC		HAROLD KUEMMEL		58-83 54TH STREET MASPETH NY 11378	02/26/2016	02/26/2021
DOL	AG		HARVINDER SINGH PAUL		90 JUNIUS STREET BROOKLYN NY 11212	01/23/2014	01/23/2019
DOL	DOL		HENRY VAN DALRYMPLE		2663 LANTERN LANE ATLANTA GA 30349	12/01/2015	12/01/2020
DOL	DOL	****6370	HILLIANO CONSTRUCTION & ELECTRICAL INC		354 MAGNOLIA STREET ROCHESTER NY 14611	01/22/2015	01/22/2020
DOL	DOL	****8282	IDEMA DEVELOPMENT INC		91 COLLEGE AVENUE POUGHKEEPSIE NY 12603	12/04/2015	12/04/2020
DOL	DOL	****8282	IDEMA GENERAL CONTRACTORS INC		91 COLLEGE AVENUE POUGHKEEPSIE NY 12603	12/04/2015	12/04/2020
DOL	DOL	****7001	INTEGRATED CONSTRUCTION & POWER SYSTEMS INC		SUITE 100 2105 W GENESEE STREETS SYRACUSE NY 13219	01/06/2016	01/06/2021
DOL	DOL	****5131	INTEGRITY MASONRY, INC.	M&R CONCRETE	722 8TH AVE WATERVLIET NY 12189	06/05/2018	06/05/2023
DOL	AG		J A M CONSTRUCTION CORP		SUITE 125 265 SUNRISE HIGHWAY ROCKVILLE CENTRE NY 10457	04/07/2016	04/07/2021
DOL	DOL	****7598	J M RICH LLC		P O BOX 268 STILLWATER NY 12170	09/16/2013	03/21/2019
DOL	DOL	****3478	J N P CONSTRUCTION CORP		50 LOUIS COURT P O BOX 1907 SOUTH HACKENSACK NY 07606	03/21/2014	03/21/2019
DOL	DOL		J N RICH LLC		P O BOX 268 STILLWATER NY 12170	09/16/2013	03/21/2019
DOL	DOL	****4910	J V MAGIC TOUCH CORPORATION		94-25 57TH AVENUE, APT 5G ELMHURST NY 11373	01/12/2015	01/12/2020
DOL	DOL		J.A. HIRES CADWALLADER		P.O BOX 100 200 LATTA BROOK PARKHORSEHEADS NY 14845	03/08/2018	03/08/2023
DOL	DOL		JAMES B RHYNDERS		91 COLLEGE AVENUE POUGHKEEPSIE NY 12603	12/04/2015	12/04/2020
DOL	DOL		JAMES C. DELGIACCO		722 8TH AVE WATERVLIET NY 12189	06/05/2018	06/05/2023
DOL	DOL		JAMES E RHYNDERS		91 COLLEGE AVENUE POUGHKEEPSIE NY 12603	12/04/2015	12/04/2020
DOL	AG		JAMES FALCONE		SUITE 125 265 SUNRISE HIGHWAY ROCKVILLE CENTRE NY 10457	04/07/2016	04/07/2021
DOL	DOL		JAMES LIACONE		9365 WASHINGTON ST LOCKPORT IL 60441	07/23/2018	07/23/2023
DOL	DOL		JAMES RACHEL		9365 WASHINGTON ST LOCKPORT IL 60441	07/23/2018	07/23/2023

NYS DOL Bureau of Public Work Debarment List 01/17/2019

Article 8

DOL	DOL		JAMES RHYNDERS SR		91 COLLEGE AVENUE POUGHKEEPSIE NY 12603	12/04/2015	12/04/2020
DOL	DOL		JAMES SICKAU		3090 SHIRLEY ROAD NORTH COLLINS NY 14111	04/19/2011	07/08/2020
DOL	DOL		JASON M RICH		P O BOX 268 STILLWATER NY 12170	09/16/2013	03/21/2019
DOL	DOL		JASON W MILLIMAN		C/O ROCHESTER ACOUSTICAL P O BOX 799HILTON NY 14468	02/19/2016	02/19/2021
DOL	DOL	*****5368	JCH MASONRY & LANDSCAPING INC.		35 CLINTON AVE OSSINING NY 10562	09/12/2018	09/12/2023
DOL	DOL		JEFF P BRADLEY		520 PINE HILL ROAD CHESTER NY 10940	06/23/2014	06/23/2019
DOL	NYC		JEFFREY CASSIDY		14 RAILROAD AVENUE VALHALLA NY 10595	05/15/2014	04/02/2020
DOL	DOL		JEROME LACITIGNOLA		C/O CATSKILL FENCE INSTAL 5445 ROUTE 32 CATSKILL NY 12414	08/22/2014	08/22/2019
DOL	DOL		JESSICA WHITESIDE		C/O BRRESTORATION NY INC 140 ARCADIA AVENUEOSWEGO NY 13126	09/12/2016	09/12/2021
DOL	AG		JOHN ANTHONY MASSINO		36-49 204TH STREET BAYSIDE NY 11372	02/07/2018	02/07/2023
DOL	DOL		JOHN F. CADWALLADER		200 LATTA BROOK PARK HORSEHEADS NY 14845	03/08/2018	03/08/2023
DOL	DOL	*****4612	JOHN F. CADWALLADER, INC.	THE GLASS COMPANY	P.O BOX 100 200 LATTA BROOK PARKHORSEHEADS NY 14845	03/08/2018	03/08/2023
DOL	AG	*****0600	JOHNCO CONTRACTING, INC.		36-49 204TH STREET BAYSIDE NY 11372	02/07/2018	02/07/2023
DOL	DOL		JON E DEYOUNG		261 MILL ROAD P O BOX 296EAST AURORA NY 14052	07/29/2015	07/29/2020
DOL	DOL		JORGE VILLALOBOS		94-25 57TH AVENUE - APT 5 ELMHURST NY 11373	01/12/2015	01/12/2020
DOL	DOL		JORI PEDERSEN		415 FLAGER AVE #302STUART FL 34994	10/31/2018	10/31/2023
DOL	DOL		JOSE CHUCHUCA		35 CLINTON AVE OSSINING NY 10562	09/12/2018	09/12/2023
DOL	DOL		JOSE MONTAS		27 BUTLER PLACE YONKERS NY 10710	03/18/2011	03/19/2020
DOL	AG		JOSEPH FALCONE		SUITE 125 265 SUNRISE HIGHWAYROCKVILLE CENTRE NY 10457	04/07/2016	04/07/2021
DOL	DOL	*****9273	JOSEPH M LOVETRO		P O BOX 812 BUFFALO NY 14220	08/09/2016	08/09/2021
DOL	NYC		JOSEPH MARTINO		1535 RICHMOND AVENUE STATEN ISLAND NY 10314	12/13/2017	12/13/2022
DOL	DOL		JOSHUA DEBOWSKY		9547 BUSTLETON AVENUE PHILADELPHIA PA 19115	02/05/2014	02/05/2019
DOL	DOL		JUANA MARTINEZ		C/O LEAD CONSTRUCTION 27 BUTLER PLACEYONKERS NY 10710	03/19/2015	03/19/2020
DOL	DOL		JULIUS AND GITA BEHREND		5 EMES LANE MONSEY NY 10952	11/20/2002	11/20/3002
DOL	DOL	*****5062	K R F SITE DEVELOPMENT INC		375 LAKE SHORE DRIVE PUTNAM VALLEY NY 10579	01/23/2017	01/23/2022
DOL	NYC		KATHLEEN SELA	C/O COLONIAL ROOFING COMPANY INC	247 48TH STREET BROOKLYN NY 11220	02/05/2014	02/05/2019
DOL	DOL		KATIE BURDICK		2238 BAKER RD GILLETT PA 16923	03/12/2018	03/12/2023
DOL	DOL		KENNETH FIORENTINO		375 LAKE SHORE DRIVE PUTNAM VALLEY NY 10579	01/23/2017	01/23/2022
DOL	DOL	*****9732	KENT HOLLOW SIDING LLC		29A BRIDGE STREET NEW MILFORD CT 06776	01/15/2016	01/15/2021
DOL	DOL		KEVIN BABCOCK JR		P O BOX 46 THOMPSON RIDGE NY 10985	08/22/2014	08/22/2019
DOL	DOL		KEVIN M BABCOCK		P O BOX 46 THOMPSON RIDGE NY 10985	08/22/2014	08/22/2019
DOL	DOL		KIM SOROCENSKI		C/O SOLUTION MATTERS INC 198 NORWOOD ROADPORT JEFFERSON NY 11776	11/19/2015	11/19/2020
DOL	DOL	*****3490	L & M CONSTRUCTION/DRYWALL INC.		1079 YONKERS AVE YONKERS NY 10704	08/07/2018	08/07/2023

NYS DOL Bureau of Public Work Debarment List 01/17/2019

Article 8

DOL	DA	****8816	LAKE CONSTRUCTION AND DEVELOPMENT CORPORATION		150 KINGS STREET BROOKLYN NY 11231	08/19/1998	08/19/2998
DOL	DOL	****6224	LAKESIDE FIRE SPRINKLERS LLC		125 CHAUTAUQUA AVENUE LAKEWOOD NY 14750	06/24/2015	06/24/2020
DOL	AG	****4643	LALO DRYWALL, INC.		221 OLD FORD ROAD NEW PLATZ NY 12561	05/20/2016	05/20/2021
DOL	DOL	****4505	LARAPINTA ASSOCIATES INC		29 MAPLEWOOD DRIVE BINGHAMTON NY 13901	02/21/2017	02/21/2022
DOL	DOL		LAVERN GLAVE		161 ROBYN RD MONROE NY 10950	09/15/2014	09/15/2019
DOL	DOL		LAVERN GLAVE		161 ROBYN RD MONROE NY 10950	01/30/2018	01/30/2023
DOL	DOL		LAWRENCE J RUGGLES		P O BOX 371 ROUND LAKE NY 12151	05/12/2014	05/12/2019
DOL	DOL	****1364	LEAD CONSTRUCTION SERVICES INC		3 ALAN B SHEPARD PLACE YONKERS NY 10705	03/19/2015	03/19/2020
DOL	DOL	****4388	LEN.J CONSTRUCTION, LLC		PO BOX 10007 ALBANY NY 12201	06/24/2016	09/19/2022
DOL	DOL	****4388	LEN.J CONSTRUCTION, LLC		PO BOX 10007 ALBANY NY 12201	06/24/2016	09/19/2022
DOL	DOL	****4388	LEN.J CONSTRUCTION, LLC		PO BOX 10007 ALBANY NY 12201	09/19/2017	09/19/2022
DOL	DOL	****4388	LEN.J CONSTRUCTION, LLC		PO BOX 10007 ALBANY NY 12201	09/19/2017	09/19/2022
DOL	DOL	****4388	LEN.J CONSTRUCTION, LLC		PO BOX 10007 ALBANY NY 12201	01/17/2017	09/19/2022
DOL	DOL	****4388	LEN.J CONSTRUCTION, LLC		PO BOX 10007 ALBANY NY 12201	09/19/2017	09/19/2022
DOL	DOL	****4388	LEN.J CONSTRUCTION, LLC		PO BOX 10007 ALBANY NY 12201	09/19/2017	09/19/2022
DOL	DOL	****4388	LEN.J CONSTRUCTION, LLC		PO BOX 10007 ALBANY NY 12201	09/19/2017	09/19/2022
DOL	DOL	****4388	LEN.J CONSTRUCTION, LLC		PO BOX 10007 ALBANY NY 12201	08/14/2017	09/19/2022
DOL	AG		LEONID FRIDMAN		APT 5 200 BRIGHTON, 15TH STBROOKLYN NY 11235	01/23/2014	01/23/2019
DOL	DOL		LEROY NELSON JR		PO BOX 10007 ALBANY NY 12201	09/19/2017	09/19/2022
DOL	DOL		LEROY NELSON JR		PO BOX 10007 ALBANY NY 12201	09/19/2017	09/19/2022
DOL	DOL		LEROY NELSON JR		PO BOX 10007 ALBANY NY 12201	09/19/2017	09/19/2022
DOL	DOL		LEROY NELSON JR		PO BOX 10007 ALBANY NY 12201	09/19/2017	09/19/2022
DOL	DOL		LEROY NELSON JR		PO BOX 10007 ALBANY NY 12201	08/14/2017	08/14/2022
DOL	DOL		LEROY NELSON JR		PO BOX 10007 ALBANY NY 12201	01/17/2017	09/19/2022
DOL	DOL		LINDSEY R CRILL		143 FILLMORE AVENUE BUFFALO NY 14210	01/08/2015	01/08/2020
DOL	DA	****4460	LONG ISLAND GLASS & STOREFRONTS, LLC		4 MANHASSET TRL RIDGE NY 11961	09/06/2018	09/06/2023
DOL	AG	****4216	LOTUS-C CORP.		81-06 34TH AVENUE APT. 6EJACKSON HEIGHTS NY 11372	02/07/2018	02/07/2023
DOL	AG		LUIS MARTINEZ	LALO DRYWALL	211 MAIN ST. NEW PALTZ NY 12561	05/20/2016	05/20/2021
DOL	DOL		M ANVER BEIG		142 EAST MARKET STREET LONG BEACH NY 11561	03/07/2017	03/07/2022
DOL	AG	****6957	M B DIN CONSTRUCTION INC		8831 20TH AVENUE/SUITE 6E BROOKLYN NY 11214	11/17/2015	11/17/2020
DOL	NYC	****6317	M S QUALITY CONSTRUCTION LLC		27 MAPLEWOOD AVENUE COLONIA NJ 07067	02/04/2015	02/04/2020
DOL	DOL		M. ANVER BEIG		142 EAST MARKET STREET LONG BEACH NY 11561	03/07/2017	03/07/2022
DOL	NYC		MACIEJ SONTOWSKI		27 MAPLEWOOD AVENUE COLONIA NJ 07067	02/04/2015	02/04/2020
DOL	NYC	****9590	MACK GLASSNAUTH IRON WORKS INC		137 LIBERTY AVENUE BROOKLYN NY 11212	12/21/2015	12/21/2020
DOL	NYC	****3141	MACKIEY REED ELECTRIC INC		1ST FLOOR STORE FRONT 88-10 LITTLE NECK PARKWAYFLORAL PARK NY 11001	06/24/2014	06/24/2019
DOL	DOL	****1784	MADISON AVE CONSTRUCTION CORP		39 PENNY STREET WEST ISLIP NY 11795	11/02/2016	11/02/2021
DOL	DOL		MALARKEY'S BAR & GRILL LLC		64 VICTORIA DRIVE BINGHAMTON NY 13904	02/04/2016	02/04/2021

NYS DOL Bureau of Public Work Debarment List 01/17/2019

Article 8

DOL	DOL	****0705	MALARKEY'S PUB & GRUB LLC		64 VICTORIA DRIVE BINGHAMTON NY 13904	02/04/2016	02/04/2021
DOL	DA		MANUEL P TOBIO		150 KINGS STREET BROOKLYN NY 14444	08/19/1998	08/19/2998
DOL	DA		MANUEL TOBIO		150 KINGS STREET BROOKLYN NY 11231	08/19/1998	08/19/2998
DOL	DOL		MARIACHI'S PIZZERIA		C/O DOUGLAS L MALARKEY 64 VICTORIA DRIVE BINGHAMTON NY 13904	02/04/2016	02/04/2021
DOL	DOL		MARK MIONIS		6409 LAND O LAKES BLVD LAND O LAKES FL 34638	11/10/2015	11/10/2020
DOL	DOL		MARVIN A STURDEVANT		29 MAPLEWOOD DRIVE BINGHAMTON NY 13901	02/21/2017	02/21/2022
DOL	DOL		MASONRY CONSTRUCTION, INC.		442 ARMONK RD MOUNT KISCO NY 10549	06/12/2018	06/12/2023
DOL	DOL	****3333	MASONRY INDUSTRIES, INC.		442 ARMONK RD MOUNT KISCO NY 10549	06/12/2018	06/12/2023
DOL	DOL		MATTHEW IDEMA GENERAL CONTRACTORS INC		91 COLLEGE AVENUE POUGHKEEPSIE NY 12603	12/04/2015	12/04/2020
DOL	DOL		MAURICE GAWENO		442 ARMONK RD MOUNT KISCO NY 10549	06/12/2018	06/12/2023
DOL	DOL	****6416	MCCALL MASONRY		P O BOX 304 SAYRE PA 18840	08/09/2016	08/09/2021
DOL	DOL	****4259	MERCANDO CONTRACTING CO INC		134 MURRAY AVENUE YONKERS NY 10704	12/11/2009	02/03/2019
DOL	DOL	****0327	MERCANDO INDUSTRIES LLC		134 MURRAY AVENUE YONKERS NY 10704	12/11/2009	02/03/2019
DOL	NYC	****5330	METRO DUCT SYSTEMS INC		1219 ASTORIA BOULEVARD LONG ISLAND CITY NY 11102	04/16/2014	11/19/2020
DOL	DOL	****3368	MICEK CONSTRUCTION CO INC		20 CROSS STREET FALCONER NY 14733	12/02/2014	12/02/2019
DOL	DOL		MICHAEL A PASCARELLA		SUITE 100 2105 WEST GENESEE STREET SYRACUSE NY 13219	01/06/2016	01/06/2021
DOL	NYC		MICHAEL HIRSCH		C/O MZM CORP 163 S MAIN STREET NEW CITY NY 10956	01/28/2016	01/28/2021
DOL	DOL		MICHAEL LENIHAN		1079 YONKERS AVE UNIT 4 YONKERS NY 10704	08/07/2018	08/07/2023
DOL	AG		MICHAEL RIGLIETTI		31 BAY ST BROOKLYN NY 11231	03/28/2018	03/28/2023
DOL	DOL		MICHAEL WILSON	WILSON BROTHER DRYWALL CONTRACTOR S	36 ABERSOLD STREET ROCHESTER NY 14621	08/31/2015	08/31/2020
DOL	NYC		MILANCE HADZIC		22 CALIFORNIA AVE - STE 1 PATERSON NJ 07503	03/11/2015	03/11/2020
DOL	AG		MOHAMMED N CHATHA		8831 20TH AVENUE/SUITE 6E BROOKLYN NY 11214	11/17/2015	11/17/2020
DOL	DOL	****2737	MOUNTAIN'S AIR INC		2471 OCEAN AVENUE- STE 7A BROOKLYN NY 11229	09/24/2012	09/18/2020
DOL	AG		MSR ELECTRICAL CONSTRUCTION CORP.		31 BAY ST BROOKLYN NY 11231	03/28/2018	03/28/2023
DOL	DOL		MUHAMMAD BEIG		142 EAST MARKET STREET LONG BEACH NY 11561	03/07/2017	03/07/2022
DOL	DOL		MUHAMMAD BEIG		142 EAST MARKET STREET LONG BEACH NY 11561	03/07/2017	03/07/2022
DOL	DOL		MUHAMMAD PERVAIZ		C/O CHAMPION CONSTRUCTION 2131 SCHENECTADY AVENUE BROOKLYN NY 11234	11/18/2015	11/18/2020
DOL	NYC	****3613	MZM CORP		163 S MAIN STREET NEW CITY NY 10956	01/28/2016	01/28/2021
DOL	NYC	****1284	NEW AMERICAN RESTORATION INC		22 CALIFORNIA AVE - STE 1 PATERSON NJ 07503	03/11/2015	03/11/2020
DOL	DA	****6988	NEW YORK INSULATION INC		58-48 59TH STREET MASPETH NY 11378	05/16/2012	05/08/2020
DOL	NYC	****4839	NEW YORK RIGGING CORP		58-83 54TH STREET MASPETH NY 11378	02/26/2016	02/26/2021
DOL	NYC		NICHOLAS PROVENZANO		147 BROOME AVENUE ATLANTIC BEACH NY 11509	03/03/2014	03/03/2019
DOL	NYC		NICHOLAS PROVENZANO		147 BROOME AVENUE ATLANTIC BEACH NY 11509	03/03/2014	03/03/2019
DOL	NYC	****1968	NORTH AMERICAN IRON WORKS INC		1560 DECATUR STREET RIDGECREEK NY 11385	05/15/2015	05/15/2020
DOL	DOL	****6966	NORTH COUNTRY DRYWALL AND PAINT		23167 COUNTY ROUTE 59 DEXTER NY 13634	10/24/2016	10/24/2021

NYS DOL Bureau of Public Work Debarment List 01/17/2019

Article 8

DOL	DOL	****0065	NORTHEAST LANDSCAPE AND MASONRY ASSOC		3 WEST MAIN ST/SUITE 208 ELMSFORD NY 10523	01/23/2017	01/23/2022
DOL	DOL	****1845	OC ERECTERS, LLC A/K/A OC ERECTERS OF NY INC.		1207 SW 48TH TERRACE DEERFIELD BEACH FL 33442	01/16/2018	01/16/2023
DOL	NYC	****8337	OPTIMUM CONSTRUCTION INC		23-73 48TH STREET LONG ISLAND CITY NY 11103	04/24/2014	04/24/2019
DOL	NYC		ORSON ARROYO		C/O METRO DUCT SYSTEMS 12-19 ASTORIA BOULEVARDLONG ISLAND CITY NY 11102	04/16/2014	11/19/2020
DOL	DOL	****4546	PAF PAINTING CORP		161 TIBBETTS ROAD YONKERS NY 10705	03/12/2014	03/12/2019
DOL	DOL	****5242	PAF PAINTING SERVICES INC	GARDEN STATE PAINTING	157 TIBBETTS ROAD YONKERS NY 10103	03/12/2014	03/12/2019
DOL	DOL		PAF PAINTING SERVICES OF WESTCHESTER INC		C/O SPIEGEL & UTRERA 1 MAIDEN LANE - 5TH FLNEW YORK NY 10038	03/12/2014	03/12/2019
DOL	DOL	****8802	PAT'S HEATING AND AIR CONDITIONING LTD		P O BOX 371 ROUND LAKE NY 12151	05/12/2014	05/12/2019
DOL	DOL		PATRICIA M RUGGLES		P O BOX 371 ROUND LAKE NY 12151	05/12/2014	05/12/2019
DOL	NYC	****9422	PELIUM CONSTRUCTION, INC.		22-33 35TH ST. ASTORIA NY 11105	12/30/2016	12/30/2021
DOL	DOL		PETER M PERGOLA		3 WEST MAIN ST/SUITE 208 ELMSFORD NY 10523	01/23/2017	01/23/2022
DOL	DOL		PIERRE LAPORT		224 COUNTY HIGHWAY 138 BROADALBIN NY 12025	03/07/2017	03/07/2022
DOL	DOL	****1543	PJ LAPORT FLOORING INC		224 COUNTY HIGHWAY 138 BROADALBIN NY 12025	03/07/2017	03/07/2022
DOL	DOL	****2989	PROFESSIONAL ESTIMATING & BUSINESS CORP		157 TIBBETS ROAD YONKERS NY 10705	03/12/2014	03/12/2019
DOL	DOL	****6895	PROLINE CONCRETE OF WNY INC		3090 SHIRLEY ROAD NORTH COLLINS NY 14111	04/19/2011	07/08/2020
DOL	DA	****6817	QUADRANT METAL BUILDINGS LLC		2740 SW MARTIN DOWNS BLVD PALM CITY FL 34990	08/25/2016	08/25/2021
DOL	NYC		RAMESHWAR ASU		137 LIBERTY AVENUE BROOKLYN NY 11212	12/21/2015	12/21/2020
DOL	DOL		RANA A KAHN		1973 81ST ST - SUITE A-5 BROOKLYN NY 11214	01/08/2015	01/08/2020
DOL	NYC		RANTIK PARIKH		13 LORIANN ROAD WARREN NJ 07059	07/15/2015	07/15/2020
DOL	DOL	****2633	RAW POWER ELECTRIC CORP		3 PARK CIRCLE MIDDLETOWN NY 10940	09/16/2013	09/15/2019
DOL	DOL	****2633	RAW POWER ELECTRIC CORP		3 PARK CIRCLE MIDDLETOWN NY 10940	01/30/2018	01/30/2023
DOL	NYC		RAYMOND PEARSON		P O BOX 957 PORT JEFFERSON STA NY 11776	03/12/2014	03/12/2019
DOL	AG	****7015	RCM PAINTING INC.		69-06 GRAND AVENUE 2ND FLOORMASPETH NY 11378	02/07/2018	02/07/2023
DOL	DOL		REGINALD WARREN		161 ROBYN RD MONROE NY 10950	09/15/2014	09/15/2019
DOL	DOL		REGINALD WARREN		161 ROBYN RD MONROE NY 10950	01/30/2018	01/30/2023
DOL	NYC	****3461	RELIANCE GENERAL CONSTRUCTION INC		644 OCEAN PARKWAY BROOKLYN NY 11230	09/02/2015	09/02/2020
DOL	DOL		REVOLUTIONARY FLOORS LLC		P O BOX 268 STILLWATER NY 12170	09/16/2013	03/21/2019
DOL	DA		RIANN MULLER		2740 SW MARTIN DOWNS BLVD PALM CITY FL 34990	08/25/2016	08/25/2021
DOL	DOL	****9148	RICH T CONSTRUCTION		107 WILLOW WOOD LANE CAMILLUS NY 13031	11/13/2018	11/13/2023
DOL	DOL		RICHARD MACONE		8617 THIRD AVE BROOKLYN NY 11209	09/17/2018	09/17/2023
DOL	DOL	****9148	RICHARD TIMIAN	RICH T CONSTRUCTION	108 LAMONT AVE SYRACUSE NY 13209	10/16/2018	10/16/2023
DOL	DOL		RICHARD TIMIAN JR.		108 LAMONT AVE SYRACUSE NY 13209	10/16/2018	10/16/2023
DOL	DOL		RICHARD TIMIAN JR.		108 LAMONT AVE SYRACUSE NY 13209	11/13/2018	11/13/2023
DOL	DOL		RICHARD WILSON		C/O DUFOUR GROUP INC 353 WEST 56TH STREET #7MNEW YORK NY 10019	06/10/2014	06/10/2019

NYS DOL Bureau of Public Work Debarment List 01/17/2019

Article 8

DOL	DOL	****8618	RIEKS CONTRACTING LLC		4804 GAHWILER ROAD AUBURN NY 13021	05/01/2015	05/01/2020
DOL	DOL		ROBBYE BISSEAR		89-51 SPRINGFIELD BLVD QUEENS VILLAGE NY 11427	01/11/2003	01/11/3003
DOL	DOL		ROBERT BRUNO		3 GAYLORD ST AUBURN NY 13021	11/15/2016	11/15/2021
DOL	DOL	****1855	ROBERT D BISHOP JR	ROBERT D BISHOP JR	P O BOX 112 MORRISONVILLE NY 12962	07/15/2014	07/15/2019
DOL	DOL		ROBERT D BISHOP JR		P O BOX 112 MORRISONVILLE NY 12962	07/15/2014	07/15/2019
DOL	NYC		ROBERT GUIDO		3256 BRUNER AVENUE BRONX NY 10469	07/29/2014	07/29/2019
DOL	DOL		ROBERT TORDELLA		125 CHAUTAUQUA AVENUE LAKEWOOD NY 14750	06/24/2015	06/24/2020
DOL	DOL	****3859	ROCHESTER ACOUSTICAL CORP		P O BOX 799 HILTON NY 14468	02/19/2016	02/19/2021
DOL	DOL		RODERICK PUGH		404 OAK ST SUITE 101SYRACUSE NY 13203	07/23/2018	07/23/2023
DOL	DOL	****4880	RODERICK PUGH CONSTRUCTION INC.		404 OAK ST SUITE 101SYRACUSE NY 13203	07/23/2018	07/23/2023
DOL	NYC		RODNEY SCOTT		201 HEMPSTEAD AVENUE WEST HEMPSTEAD NY 11552	10/30/2015	10/30/2020
DOL	DOL		ROMEO WARREN		161 ROBYN RD MONROE NY 10950	09/16/2013	09/15/2019
DOL	DOL		ROMEO WARREN		161 ROBYN RD MONROE NY 10950	01/30/2018	01/30/2023
DOL	DOL		ROSEANNE CANTISANI			06/12/2018	06/12/2023
DOL	DOL		RYAN ALBIE		21 S HOWELLS POINT ROAD BELLPORT NY 11713	02/21/2017	02/21/2022
DOL	DOL	****3347	RYAN ALBIE CONTRACTING INC		21 S HOWELLS POINT ROAD BELLPORT NY 11713	02/21/2017	02/21/2022
DOL	NYC		SABIR MUHAMMED		SUITE B-8 782 PELHAM PARKWAY SOUTHBRONX NY 10462	04/21/2016	04/21/2021
DOL	NYC		SAEED HASAN		4558 BROADWAY #6 NEW YORK NY 10040	08/04/2014	08/04/2019
DOL	NYC	****2117	SCOTT ELECTRICAL LLC		201 HEMPSTEAD AVENUE WEST HEMPSTEAD NY 11552	10/30/2015	10/30/2020
DOL	DOL	****9751	SCW CONSTRUCTION		544 OLD ROUTE 23 ACRE NY 12405	02/14/2017	02/14/2022
DOL	DOL		SEAN BURBAGE	C/O SEAN BURBAGE CORP	445 ROOSA GAP ROAD BLOOMINGBURG NY 12721	04/14/2014	04/14/2019
DOL	DOL	****6586	SEAN BURBAGE CORP		445 ROOSA GAP ROAD BLOOMINGBURG NY 12721	04/14/2014	04/14/2019
DOL	AG		SERGIO RAYMUNDO		109 DUBOIS RD. NEW PALTZ NY 12561	05/20/2016	05/20/2021
DOL	DOL	****1961	SHANE BURDICK	CENTRAL TRAFFIC CONTROL, LLC.	2238 BAKER ROAD GILLET PA 16923	03/12/2018	03/12/2023
DOL	DOL		SHANE BURDICK		2238 BAKER ROAD GILLET PA 16923	03/12/2018	03/12/2023
DOL	DOL		SHANE NOLAN		9365 WASHINGTON ST LOCKPORT IL 60441	07/23/2018	07/23/2023
DOL	DOL	****0816	SOLAR ARRAY SOLUTIONS, LLC		9365 WASHINGTON ST LOCKPORT IL 60441	07/23/2018	07/23/2023
DOL	DOL	****4025	SOLUTION MATTERS INC		198 NORWOOD ROAD PORT JEFFERSON NY 11776	11/19/2015	11/19/2020
DOL	NYC	****4934	SPHINX CONTRACTING CORP		240 HOME STREET TEANECK NJ 07666	08/04/2014	08/04/2019
DOL	DOL	****3496	STAR INTERNATIONAL INC		89-51 SPRINGFIELD BLVD QUEENS VILLAGE NY 11427	08/11/2003	08/11/3003
DOL	DOL	****9751	STEPHEN C WAGAR		544 OLD ROUTE 23 ACRE NY 12405	02/14/2017	02/14/2022
DOL	DOL		STEVE TATE		415 FLAGER AVE #302STUART FL 34994	10/31/2018	10/31/2023
DOL	DOL		STEVEN P SUCATO		15-68 208TH STREET BAYSIDE NY 11360	06/23/2016	06/23/2021
DOL	DOL		STEVEN SAGGESE		3005 WYNSUM AVENUE MERRICK NY 11566	08/18/2014	08/18/2019
DOL	DOL		STEVEN TESTA		50 SALEM STREET - BLDG B LYNNFIELD MA 01940	01/23/2017	01/23/2022

NYS DOL Bureau of Public Work Debarment List 01/17/2019

Article 8

DOL	NYC	****9432	SUBLINK LTD		346 THIRD AVENUE PELHAM NY 10803	11/19/2015	11/19/2020
DOL	DOL	****7441	T & T CONCRETE INC		2560 HAMBURG TURNPIKE P O BOX 367LACKAWANNA NY 14218	07/08/2015	07/08/2020
DOL	DOL	****7417	TADCO CONSTRUCTION		101-61 99TH STREET OZONE PARK NY 11416	02/15/2017	02/15/2022
DOL	DOL		TADCO CONSTRUCTION		101-61 99TH STREET OZONE PARK NY 11416	02/15/2017	02/15/2022
DOL	DOL	****7417	TADCO CONSTRUCTION CORP		101-61 99TH STREET OZONE PARK NY 11416	02/15/2017	02/15/2022
DOL	DOL		TALAILA OCAMPA		1207 SW 48TH TERRACE DEERFIELD BEACH FL 33442	01/16/2018	01/16/2023
DOL	DOL		TAMMY LACITIGNOLA		C/O CATSKILL FENCE INSTAL 5445 ROUTE 32CATSKILL NY 12414	08/22/2014	08/22/2019
DOL	DOL	****9852	TAP STEEL INC		ROUTE 26 3101 P O BOX 457CONSTABLEVILLE NY 13325	01/28/2016	01/28/2021
DOL	DOL		TECH-MECHANICAL FAB DC INC		5 PARKER AVENUE POUGHKEEPSIE NY 12601	03/25/2014	03/25/2019
DOL	DOL	****5570	TESTA CORP		50 SALEM STREET - BLDG B LYNNFIELD MA 01940	01/23/2017	01/23/2022
DOL	DOL	****0887	THE BRINSON PAINTING CORPORATION		72 TAUNTON PLACE BUFFALO NY 14216	04/14/2015	04/14/2020
DOL	DOL	****5766	THE COKER CORPORATION	COKER CORPORATIO N	2610 SOUTH SALINA ST SUITE 14SYRACUSE NY 13205	12/04/2018	12/04/2023
DOL	DOL	****8174	THE DALRYMPLE CORPORATION		UNIT 278 541 10TH STREET NWTALANTA GA 30318	12/01/2015	12/01/2020
DOL	DOL	****8174	THE DALRYMPLE GROUP LLC		289 JONESBORO RD/ STE 216 MCDONOUGH GA 30253	12/01/2015	12/01/2020
DOL	DOL	****9243	THE WELCOME MAT PROPERTY MANAGEMENT LLC		P O BOX 268 STILLWATER NY 12170	09/16/2013	03/21/2019
DOL	DOL		TIMOTHY A PALUCK		C/O TAP STEEL INC RTE 26 3101/ P O BOX 457CONSTABLEVILLE NY 13325	01/28/2016	01/28/2021
DOL	DOL	****0600	TOMSON ALLOYS RECYCLING INC		143 FILLMORE AVENUE BUFFALO NY 14210	01/08/2015	01/08/2020
DOL	DOL	****3453	TORCHIA'S HOME IMPROVEMENT		10153 ROBERTS RD SAUQUOIT NY 13456	08/09/2016	08/09/2021
DOL	DOL	****6914	TRI-COUNTY RESTORATIONS & CONSTRUCTION INC		13 SUMMERSET DRIVE WALLKILL NY 12589	08/22/2014	08/22/2019
DOL	DOL		TRI-COUNTY RESTORATIONS INC		392 ROCK CUT ROAD WALDEN NY 12586	08/22/2014	08/22/2019
DOL	DOL	****8311	TRIPLE B FABRICATING, INC.		61 WILLET ST. PASSAIC NJ 07503	10/26/2016	10/26/2021
DOL	DOL	****9407	TURBO GROUP INC		15-68 208TH STREET BAYSIDE NY 11360	06/23/2016	06/23/2021
DOL	AG	****6490	UNIVERSAL STEEL FABRICATORS INC		90 JUNIUS STREET BROOKLYN NY 11212	01/23/2014	01/23/2019
DOL	NYC	****7174	V&R CONTRACTING		P O BOX 957 PORT JEFFERSON STA NY 11776	03/12/2014	03/12/2019
DOL	DOL	****6392	V.M.K CORP.		8617 THIRD AVE BROOKLYN NY 11209	09/17/2018	09/17/2023
DOL	NYC		VALERIE VISCONTI		346 THIRD AVENUE PELHAM NY 10803	11/19/2015	11/19/2020
DOL	NYC		VEAP SELA	C/O COLONIAL ROOFING COMPANY INC	247 48TH STREET BROOKLYN NY 11220	02/05/2014	02/05/2019
DOL	DOL		VICTOR ROTENBERG		C/O GMDV TRANS INC 67048 182ND STREETFRESH MEADOWS NY 11365	06/24/2016	06/24/2021
DOL	NYC		VIKTAR PATONICH		2630 CROPSY AVE BROOKLYN NY 11214	10/30/2018	10/30/2023
DOL	NYC		VINCENT PIZZITOLA		P O BOX 957 PORT JEFFERSON STA NY 11776	03/12/2014	03/12/2019
DOL	NYC		VITO GARGANO		1535 RICHMOND AVE STATEN ISLAND NY 10314	12/13/2017	12/13/2022
DOL	DOL		WAYNE LIVINGSTON JR	NORTH COUNTRY DRYWALL AND PAINT	23167 COUNTY ROUTE 59 DEXTER NY 13634	10/24/2016	10/24/2021

NYSDOL Bureau of Public Work Debarment List 01/17/2019

Article 8

DOL	DOL		WHITE PLAINS CARPENTRY CORP		442 ARMONK RD	06/12/2018	06/12/2023
DOL	DOL		WILLIAM CONKLIN		5 PARKER AVENUE POUGHKEEPSIE NY 12601	03/25/2014	03/25/2019
DOL	DOL		WILLIAM DEAK		C/O MADISON AVE CONSTR CO 39 PENNY STREETWEST ISLIP NY 11795	11/02/2016	11/02/2021
DOL	DOL		WILLIAM MAZZELLA		134 MURRAY AVENUE YONKERS NY 10704	02/03/2014	02/03/2019
DOL	DOL		WILLIE BRINSON		72 TAUNTON PLACE BUFFALO NY 14216	04/14/2015	04/14/2020
DOL	DOL	****6195	WILSON BROTHER DRYWALL CONTRACTORS		36 ABERSOLD STREET ROCHESTER NY 14621	08/31/2015	08/31/2020
DOL	DOL	****4043	WINDSHIELD INSTALLATION NETWORK, INC.		200 LATTA BROOK PARK HORSEHEADS NY 14845	03/08/2018	03/08/2023
DOL	DOL	****4730	XGD SYSTEMS, LLC	TDI GOLF	415 GLAGE AVE #302STUART FL 34994	10/31/2018	10/31/2023
DOL	DOL	****7345	YES SERVICE AND REPAIRS CORPORATION		145 LODGE AVE HUNTINGTON STATION NY 11476	08/09/2016	08/09/2021
DOL	DOL		YURIY IVANIN		C/O MOUNTAIN'S AIR INC 2471 OCEAN AVENUE-STE 7ABROOKLYN NY 11229	09/24/2012	09/18/2020
DOL	NYC		ZAKIR NASEEM		30 MEADOW ST BROOKLYN NY 11206	10/10/2017	10/10/2022
DOL	NYC	****8277	ZHN CONTRACTING CORP		30 MEADOW ST BROOKLYN NY 11206	10/10/2017	10/10/2022

General Decision Number: NY190006 01/04/2019 NY6

Superseded General Decision Number: NY20180006

State: New York

Construction Types: Heavy and Highway

Counties: Clinton and Essex Counties in New York.

BUILDING CONSTRUCTION PROJECTS (does not include single family homes and apartments up to and including 4 stories), HEAVY AND HIGHWAY CONSTRUCTION PROJECTS

Note: Under Executive Order (EO) 13658, an hourly minimum wage of \$10.60 for calendar year 2019 applies to all contracts subject to the Davis-Bacon Act for which the contract is awarded (and any solicitation was issued) on or after January 1, 2015. If this contract is covered by the EO, the contractor must pay all workers in any classification listed on this wage determination at least \$10.60 per hour (or the applicable wage rate listed on this wage determination, if it is higher) for all hours spent performing on the contract in calendar year 2019. If this contract is covered by the EO and a classification considered necessary for performance of work on the contract does not appear on this wage determination, the contractor must pay workers in that classification at least the wage rate determined through the conformance process set forth in 29 CFR 5.5(a)(1)(ii) (or the EO minimum wage rate, if it is higher than the conformed wage rate). The EO minimum wage rate will be adjusted annually. Please note that this EO applies to the above-mentioned types of contracts entered into by the federal government that are subject to the Davis-Bacon Act itself, but it does not apply to contracts subject only to the Davis-Bacon Related Acts, including those set forth at 29 CFR 5.1(a)(2)-(60). Additional information on contractor requirements and worker protections under the EO is available at www.dol.gov/whd/govcontracts.

Modification Number	Publication Date
0	01/04/2019

* BRNY0002-013 06/01/2018

	Rates	Fringes
CEMENT MASON/CONCRETE FINISHER...	\$ 37.23	19.51+a

FOOTNOTE:

a. PAID HOLIDAYS: Memorial Day, July the 4th, Labor Day, and Thanksgiving Day (provided the employee is employed (1) day before and (1) day after the holiday).

CARP0291-006 07/01/2018

	Rates	Fringes
CARPENTER HEAVY & HIGHWAY CONSTRUCTION		
Carpenter.....	\$ 31.48	21.15
Pile Driver.....	\$ 31.48	21.15

ELEC0910-001 04/01/2018

	Rates	Fringes
ELECTRICIAN.....	\$ 34.50	5.75%+19.68

ELEC1249-003 05/07/2018

	Rates	Fringes
ELECTRICIAN (LINE CONSTRUCTION: LIGHTING AND TRAFFIC SIGNAL Including any and all Fiber Optic Cable necessary for Traffic Signal Systems, Traffic Monitoring systems and Road Weather information systems)		
Flagman.....	\$ 26.28	6.75%+23.40+a
Groundman (Truck Driver)....	\$ 35.04	6.75%+23.40+a
Groundman Truck Driver (tractor trailer unit).....	\$ 37.23	6.75%+23.40+a
Lineman & Technician.....	\$ 43.80	6.75%+23.40+a
Mechanic.....	\$ 35.04	6.75%+23.40+a

FOOTNOTE:

a. New Year's Day, Memorial Day, Independence Day, Labor Day, Thanksgiving Day, Christmas Day, plus President's Day, Good Friday, Decoration Day, Election Day for the President of the United States and Election Day for the Governor of the State of New York, provided the employee works the day before or the day after the holiday.

ELEC1249-004 05/07/2018

	Rates	Fringes
ELECTRICIAN (Line Construction) Overhead and underground distribution and maintenance work and all overhead and underground transmission line work including any and all		

fiber optic ground wire,
 fiber optic shield wire or
 any other like product by
 any other name
 manufactured for the dual
 purpose of ground fault
 protection and fiber optic
 capabilities :

Flagman.....	\$ 30.36	6.75%+23.40+a
Groundman digging machine operator.....	\$ 45.54	6.75%+23.40+a
Groundman truck driver (tractor trailer unit).....	\$ 43.01	6.75%+23.40+a
Groundman Truck driver.....	\$ 40.48	6.75%+23.40+a
Lineman and Technician.....	\$ 50.60	6.75%+23.40+a
Mechanic.....	\$ 40.48	6.75%+23.40+a

Substation:

Cable Splicer.....	\$ 55.66	6.75%+23.40+a
Flagman.....	\$ 30.36	6.75%+23.40+a
Ground man truck driver....	\$ 40.48	6.75%+23.40+a
Groundman digging machine operator.....	\$ 45.54	6.75%+23.40+a
Groundman truck driver (tractor trailer unit).....	\$ 43.01	6.75%+23.40+a
Lineman & Technician.....	\$ 50.60	6.75%+23.40+a
Mechanic.....	\$ 40.48	6.75%+23.40+a

Switching structures;
 railroad catenary
 installation and
 maintenance, third rail
 type underground fluid or
 gas filled transmission
 conduit and cable
 installations (including
 any and all fiber optic
 ground product by any
 other name manufactured
 for the dual purpose of
 ground fault protection
 and fiber optic
 capabilities), pipetype
 cable installation and
 maintenance jobs or
 projects, and maintenance
 bonding of rails; Pipetype
 cable installation

Cable Splicer.....	\$ 57.11	6.75%+23.40+a
Flagman.....	\$ 31.15	6.75%+23.40
Groundman Digging Machine Operator.....	\$ 46.73	6.75%+23.40+a
Groundman Truck Driver (tractor-trailer unit).....	\$ 44.13	6.75%+23.40+a
Groundman Truck Driver.....	\$ 44.13	6.75%+23.40+a
Lineman & Technician.....	\$ 51.92	6.75%+23.40+a
Mechanic.....	\$ 41.54	6.75%+23.40+a

FOOTNOTE:

a. PAID HOLIDAYS: New Year's Day, Presidents' Day, Memorial Day, Good Friday, Independence Day, Labor Day, Thanksgiving Day, Christmas Day, and Election Day for the President of the United States and Election Day for the Governor of New York State, provided the employee works two days before or two days after the holiday.

 ELEC1249-008 01/01/2018

	Rates	Fringes
ELECTRICIAN (Line Construction)		
TELEPHONE, CATV		
FIBEROPTICS CABLE AND EQUIPMENT		
Cable splicer.....	\$ 31.83	3%+4.73
Groundman.....	\$ 16.01	3%+4.73
Installer Repairman-Teledata		
Lineman/Technician-Equipment Operator.....		
	\$ 30.21	3%+4.73
Tree Trimmer.....	\$ 23.95	3%+9.98+a

a. New Year's Day, President's Day, Good Friday, Decoration Day, Independence Day, Labor Day, Veteran's Day, Thanksgiving Day, Day after Thanksgiving, Christmas Day.

 ENGI0106-001 07/01/2018

HEAVY & HIGHWAY

	Rates	Fringes
Power equipment operators:		
GROUP 1.....	\$ 43.47	26.05+a
GROUP 2.....	\$ 42.56	26.05+a
GROUP 3.....	\$ 39.99	26.05+a
GROUP 4.....	\$ 47.47	26.05+a
GROUP 5.....	\$ 46.47	26.05+a
GROUP 6.....	\$ 45.47	26.05+a
GROUP 7.....	\$ 45.08	26.05+a

POWER EQUIPMENT OPERATOR CLASSIFICATIONS (HEAVY & HIGHWAY):

GROUP 1: Asphalt Curb Machine, Self Propelled, Slipform, Automated Concrete Spreader (CMI Type), Automatic Fine Grader, Backhoe (Except Tractor Mounted, Rubber Tired), Backhoe Excavator Full Swing (CAT 212 or similar type), Back Filling Machine, Belt Placer (CMI Type), Blacktop Plant (Automated), Boom truck , Cableway, Caisson Auger, Central Mix Concrete Plant (Automated), Concrete Curb Machine, Self Propelled, Slipform, Concrete Pump, Crane, Cherry Picker, Derricks (steel erection), Dragline, Overhead Crane (Gantry or Straddle type), Pile Driver, Truck Crane, Directional Drilling Machine, Dredge, Dual

Drum Paver, Excavator (All Purpose Hydraulically Operated) (Gradall or Similar), Front End Loader (4 cu. yd. and Over), Head Tower (Sauerman or Equal), Hoist (Two or Three Drum), Holland Loader, Maintenance Engineer, Mine Hoist, Mucking Machine or Mole Pavement Breaker(SP) Wertgen; PB-4 and similar type, Power Grader, Profiler (over 105 H.P.) Quad 9, Quarry Master (or equivalent), Scraper, Fireman, Form Tamper, Grout Pump, Gunite Machine, Hammers (Hydraulic self-propelled), Hydra-Spiker, ride-on, Hydraulic Pump (jacking system), Hydro-Blaster (Water), Mulching Machine, Oiler, Parapet Concrete or Pavement, Shovel, Side Boom, Slip Form Paver, Tractor Drawn, BeltType Loader, Truck or Trailer Mounted Log , Chipper (Self Feeder), Tug Operator (Manned Rented Equipment Excluded), Tunnel Shovel

GROUP 2: Asphalt Paver, Backhoe (Tractor Mounted, Rubber Tired), Bituminous Recycler Machine, Bituminous Spreader and Mixer, Blacktop Plant (NonAutomated), Blast or Rotary Drill (Truck or Tractor Mounted), Boring Machine, Cage Hoist, Central Mix Plant (NonAutomated) and All Concrete Batching Plants, Cherry Picker (5 tons capacity and under), Concrete Paver (Over 16S), Crawler Drill, Self-contained, Crusher, Diesel Power Unit, Drill Rigs, Tractor Mounted, Front End Loader (Under 4 cu. yd.), Greaseman/Lubrication Engineer, HiPressure Boiler (15 lbs. and over), Hoist (One Drum), Hydro-Axe, Kolman Plant Loader and Similar Type Loaders, L.C.M. Work Boat Operator, Locomotive Mixer (for stabilized base selfpropelled), Monorail Machine, Plant Engineer, Profiler (105 H.P. and under), Grinder, Post Hole Digger and Post Driver, Power Broom (towed), Power Heaterman, Power Sweeper, Revinius Widener, Roller (Grade and Fill), Scarifier, ride-on, Shell Winder, Skid steer loader (Bobcat or similar), Span-Saw, ride-on, Steam Cleaner, Pug Mill, Pump Crete Ready Mix Concrete Plant Refrigeration Equipment (for soil stabilization)Road Widener, Roller (all above subgrade), Sea Mule, Self-contained Ride-on Rock Drill, Excluding Air-Track Type Drill, Skidder, Tractor with Dozer and/or Pusher, Trencher. Tugger Hoist, Vermeer saw (ride on, any size or type), Winch, Winch Cat

GROUP 3: A Frame Winch Hoist on Truck , Articulated Heavy Hauler, Aggregate Plant, Asphalt or Concrete Grooving, Machine (ride on), Ballast Regulator, Ride-on Boiler (used in conjunction with production), Bituminous Heater, self-propelled, Boat (powered), Cement and Bin Operator, Compressors, Dust Collectors, Fork Lift, Generators, Pumps, Welding Machines, Light Plants, Heaters (hands-off equipment), Concrete Pavement Spreader and Finisher, Concrete Paver or Mixer (16S and under), Concrete Saw (self-propelled), Conveyor, Deck Hand, Directional Drill Machine Locator, Drill, (Core), Drill, (Well,) Farm Tractor with accessories, Fine Grade Machine, Tamper, ride-on, Tie Extractor, ride-on, Tie Handler, ride-on, Tie Inserter, ride-on, Tie Spacer, ride-on, Tire Repair, Track Liner, ride-on, Tractor, Tractor (with towed accessories), Vibratory Compactor, Vibro Tamp, Well Point

GROUP 4: Tower Cranes

GROUP 5: Cranes 50 tons and over

GROUP 6: Cranes 49 tons and below

GROUP 7: Master Mechanic

FOOTNOTE:

a. PAID HOLIDAYS: New Year's Day, Memorial Day, Independence Day, Labor Day, Thanksgiving Day, and Christmas Day

IRON0012-002 07/01/2018

	Rates	Fringes
Ironworkers:		
SHEETER.....	\$ 31.25	24.43
STRUCTURAL, ORNAMENTAL, MACHINERY MOVER & RIGGERS, FENCE ERECTOR, REINFORCING, STONE DERRICKMAN, WELDER.....	\$ 31.00	24.43

LABO1822-001 07/01/2018

HEAVY & HIGHWAY

	Rates	Fringes
Laborers:		
GROUP 1.....	\$ 25.67	23.75+a
GROUP 2.....	\$ 25.47	23.75+a
GROUP 3.....	\$ 25.87	23.75+a
GROUP 4.....	\$ 26.07	23.75+a
GROUP 5.....	\$ 27.67	23.75+a

LABORERS CLASSIFICATIONS (HEAVY & HIGHWAY)

GROUP 1. Basic Rate, Flagman Outboard and Hand Boats.

GROUP 2. Bull Float, Chain Saw, Concrete Aggregate Bin, Concrete Bootman, Gin Buggy, Hand or Machine Vibrator, Jack Hammer, Mason Tender, Mortar Mixer Paverment Breaker, Handlers of all Steel Mesh, Small Generators of Laborers' tools, installation of bridge drainage pipe, Pipe Layers, Vibrator type rollers, tamper, Drill doctor, tail or screw operator on asphalt paver, water pump operator (1 1/2" and single diaphragm) nozzle (asphalt, gunite, seeding and sand blasting), Laborers on chain link fence erection, Rock splitter and power unit, pusher type concrete saw and all other gas, electric, oil and air tool operators, Wrecking Labor.

GROUP 3. All rock or drilling machine operators (except quarry master and similar type) Acetylene Torch operator,

asphalt raker, powderman.

GROUP 4. Blaster, form setters, stone or granite curb setters.

GROUP 5. Hazardous Waste, Asbestos Abatement and Removal.

FOOTNOTE:

a. PAID HOLIDAYS: New Year's Day, Memorial Day, Independence Day, Labor Day, Thanksgiving Day and Christmas Day.

PAIN0201-002 05/01/2017

	Rates	Fringes
Painters:		
Zone #2 All of ESSEX COUNTY		
Lead Abatement Workers, Structural Steel.....	\$ 30.00	13.89
Painters, Drywall Finishers, Spray.....	\$ 29.00	13.89
Zone #3 All of CLINTON COUNTY		
Lead Abatement Workers, Structural Steel.....	\$ 28.14	14.55
Painters, Drywall Finishers, Spray.....	\$ 27.14	14.55

PAIN0806-003 10/01/2018

CLINTON AND ESSEX COUNTIES

	Rates	Fringes
Painters:		
Structural Steel and Bridge.	\$ 49.50	41.88

PLUM0773-001 05/01/2018

	Rates	Fringes
Plumber and Steamfitter		
CLINTON COUNTY.....	\$ 37.00	29.83
ESSEX COUNTY.....	\$ 38.00	29.83

SHEE0083-001 06/01/2018

	Rates	Fringes
Sheet metal worker.....	\$ 33.12	31.78+a

FOOTNOTE:

a. PAID HOLIDAYS: New Year's Day, Memorial Day, Independence Day, Labor Day, Thanksgiving Day, Christmas Day. If any of these holidays fall on a Saturday or Sunday, either the preceding Friday or following Monday will be observed as the holiday.

TEAM0687-003 06/01/2018

	Rates	Fringes
Truck drivers:		
HEAVY & HIGHWAY		
CONSTRUCTION		
GROUP 1:.....	\$ 25.82	25.16+a
GROUP 2:.....	\$ 26.04	25.16+a

FOOTNOTE:

- a. PAID HOLIDAYS: New Year's Day, Memorial Day, Independence Day, Labor Day, Thanksgiving Day, Christmas Day, provided the employee has worked the day before and the day after the holiday.

TRUCK DRIVER CLASSIFICATIONS

GROUP 1: Pick-ups, panel trucks, flatboy materials trucks (straight jobs), single axle dump trucks, dumpsters and receivers, greasers, truck tireman, parts chaser, tandems and batch trucks, mechanics, semi trailer, lowboy trucks, asphalt distributor trucks and agitator, mixer trucks and dumpcrete type vehicles, truck mechanic, fuel truck and bus

GROUP 2: Specialized earth moving equipment - euclid type or similar off-highway equipment, where not self-loaded, straddle (ross) carrier, self-contained concrete unit, off highway tandem back dump, twin engine equipment and double hitched equipment where not self loaded

WELDERS - Receive rate prescribed for craft performing operation to which welding is incidental.

=====
Note: Executive Order (EO) 13706, Establishing Paid Sick Leave for Federal Contractors applies to all contracts subject to the Davis-Bacon Act for which the contract is awarded (and any solicitation was issued) on or after January 1, 2017. If this contract is covered by the EO, the contractor must provide employees with 1 hour of paid sick leave for every 30 hours they work, up to 56 hours of paid sick leave each year. Employees must be permitted to use paid sick leave for their own illness, injury or other health-related needs, including preventive care; to assist a family member (or person who is like family to the employee) who is ill, injured, or has other health-related needs, including preventive care; or for reasons resulting from, or to assist a family member (or person who is like family to the employee) who is a victim of, domestic violence, sexual assault, or stalking. Additional information on contractor requirements and worker protections under the EO is available at www.dol.gov/whd/govcontracts.

Unlisted classifications needed for work not included within the scope of the classifications listed may be added after award only as provided in the labor standards contract clauses (29CFR 5.5 (a) (1) (ii)).

The body of each wage determination lists the classification and wage rates that have been found to be prevailing for the cited type(s) of construction in the area covered by the wage determination. The classifications are listed in alphabetical order of "identifiers" that indicate whether the particular rate is a union rate (current union negotiated rate for local), a survey rate (weighted average rate) or a union average rate (weighted union average rate).

Union Rate Identifiers

A four letter classification abbreviation identifier enclosed in dotted lines beginning with characters other than "SU" or "UAVG" denotes that the union classification and rate were prevailing for that classification in the survey. Example: PLUM0198-005 07/01/2014. PLUM is an abbreviation identifier of the union which prevailed in the survey for this classification, which in this example would be Plumbers. 0198 indicates the local union number or district council number where applicable, i.e., Plumbers Local 0198. The next number, 005 in the example, is an internal number used in processing the wage determination. 07/01/2014 is the effective date of the most current negotiated rate, which in this example is July 1, 2014.

Union prevailing wage rates are updated to reflect all rate changes in the collective bargaining agreement (CBA) governing this classification and rate.

Survey Rate Identifiers

Classifications listed under the "SU" identifier indicate that no one rate prevailed for this classification in the survey and the published rate is derived by computing a weighted average rate based on all the rates reported in the survey for that classification. As this weighted average rate includes all rates reported in the survey, it may include both union and non-union rates. Example: SULA2012-007 5/13/2014. SU indicates the rates are survey rates based on a weighted average calculation of rates and are not majority rates. LA indicates the State of Louisiana. 2012 is the year of survey on which these classifications and rates are based. The next number, 007 in the example, is an internal number used in producing the wage determination. 5/13/2014 indicates the survey completion date for the classifications and rates under that identifier.

Survey wage rates are not updated and remain in effect until a new survey is conducted.

Union Average Rate Identifiers

Classification(s) listed under the UAVG identifier indicate that no single majority rate prevailed for those classifications; however, 100% of the data reported for the classifications was union data. EXAMPLE: UAVG-OH-0010 08/29/2014. UAVG indicates that the rate is a weighted union average rate. OH indicates the state. The next number, 0010 in the example, is an internal number used in producing the wage determination. 08/29/2014 indicates the survey completion date for the classifications and rates under that identifier.

A UAVG rate will be updated once a year, usually in January of each year, to reflect a weighted average of the current negotiated/CBA rate of the union locals from which the rate is based.

WAGE DETERMINATION APPEALS PROCESS

1.) Has there been an initial decision in the matter? This can be:

- * an existing published wage determination
- * a survey underlying a wage determination
- * a Wage and Hour Division letter setting forth a position on a wage determination matter
- * a conformance (additional classification and rate) ruling

On survey related matters, initial contact, including requests for summaries of surveys, should be with the Wage and Hour Regional Office for the area in which the survey was conducted because those Regional Offices have responsibility for the Davis-Bacon survey program. If the response from this initial contact is not satisfactory, then the process described in 2.) and 3.) should be followed.

With regard to any other matter not yet ripe for the formal process described here, initial contact should be with the Branch of Construction Wage Determinations. Write to:

Branch of Construction Wage Determinations
Wage and Hour Division
U.S. Department of Labor
200 Constitution Avenue, N.W.
Washington, DC 20210

2.) If the answer to the question in 1.) is yes, then an interested party (those affected by the action) can request review and reconsideration from the Wage and Hour Administrator (See 29 CFR Part 1.8 and 29 CFR Part 7). Write to:

Wage and Hour Administrator
U.S. Department of Labor

200 Constitution Avenue, N.W.
Washington, DC 20210

The request should be accompanied by a full statement of the interested party's position and by any information (wage payment data, project description, area practice material, etc.) that the requestor considers relevant to the issue.

3.) If the decision of the Administrator is not favorable, an interested party may appeal directly to the Administrative Review Board (formerly the Wage Appeals Board). Write to:

Administrative Review Board
U.S. Department of Labor
200 Constitution Avenue, N.W.
Washington, DC 20210

4.) All decisions by the Administrative Review Board are final.

=====

END OF GENERAL DECISION

VII. REQUIRED CONTRACT PROVISIONS FOR FEDERAL AID PROJECTS

CONTENTS

- Certification for Federal Aid Contracts (See Section II of this Project Manual)
- Disclosure of Lobbying Activities (See Section II of this Project Manual))
- Non-Collusive Bidding Certification (See Section II of this Project Manual)
- U.S. Department of Transportation Hotline Information (See Section II of this Project Manual)
- Equal Employment Opportunity Requirements. (See Section 102-11 of the NYSDOT Standard Specifications)
- FHWA-1273 Required Contract Provisions.
- Supplemental Title VI Provisions (Civil Rights Act)

NYSDOT Standard Specifications required for Federal Aid Contracts:

- Non-Collusive Bidding and Other Certifications NYSDOT Standard Specifications, Section 102-08
- Prevailing Wage Rates, Use of Convict Labor and Materials Provisions, NYSDOT Standard Specifications, Section 102-10
- Federal Changed Conditions Clauses and Disputed Work Provisions, NYSDOT Standard Specifications, Section 104-03, 04 and 05
- Insurance Provisions, NYSDOT Standard Specifications, Section 107-06
- Retainage Provisions, NYSDOT Standard Specifications, Section 109-07
- Prompt Payment Provisions, NYSDOT Standard Specifications, Section 109-07.
- Buy America Provisions, NYSDOT Standard Specifications, Section 106-11
- Safety and Health Requirements, Section 107-05 (including Fall Protection, Electrical Safety, Histoplasmosis, etc)

(This page intentionally left blank)

EQUAL EMPLOYMENT OPPORTUNITY REQUIREMENTS

**[SEE SECTION 102-11 OF THE
NEW YORK STATE
DEPARTMENT OF TRANSPORTATION STANDARD SPECIFICATIONS]**

GOALS FOR MINORITY PARTICIPATION IN THE CONSTRUCTION INDUSTRY

COUNTY GOAL	% GOAL	COUNTY	% GOAL	COUNTY	%
Albany	3.2	Herkimer	2.1	Richmond	*
Allegany	6.3	Jefferson	2.5	Rockland	22.6
Broome	1.1	Kings	*	St. Lawrence	2.5
Bronx	*	Lewis	2.5	Saratoga	3.2
Cattaraugus	6.3	Livingston	5.3	Schenectady	3.2
Cayuga	2.5	Madison	3.8	Schoharie	2.6
Chautauqua	6.3	Monroe	5.3	Schuyler	1.2
Chemung	2.2	Montgomery	3.2	Seneca	5.9
Chenango	1.2	Nassau	5.8	Steuben	1.2
Clinton	2.6	New York	*	Suffolk	5.8
Columbia	2.6	Niagara	7.7	Sullivan	17.0
Cortland	2.5	Oneida	2.1	Tioga	1.1
Delaware	1.2	Onondaga	3.8	Tompkins	1.2
Dutchess	6.4	Ontario	5.3	Ulster	17.0
Erie	7.7	Orange	17.0	Warren	2.6
Essex	2.6	Orleans	5.3	Washington	2.6
Franklin	2.5	Oswego	3.8	Wayne	5.3
Fulton	2.6	Otsego	1.2	Westchester	22.6
Genesee	5.9	Putnam	22.6	Wyoming	6.3
Greene	2.6	Queens	*	Yates	5.9
Hamilton	2.6	Rensselaer	3.2		

*** The following goal ranges are applicable to the indicated trades in the Counties of Bronx, Kings, New York, Queens, and Richmond:**

Electricians.....	9.0 to 10.2
Carpenters.....	27.6 to 32.0
Steam Filters.....	2.2 to 13.5
Metal Lathers.....	26.0 to 28.6
Operating Engineers.....	25.6 to 26.0
Plumbers.....	12.0 to 14.5
Iron Workers (Structural).....	25.9 to 32.0
Elevator Constructors.....	5.5 to 6.5
Bricklayers.....	13.4 to 15.5
Asbestos Workers.....	22.8 to 28.0
Roofers.....	6.3 to 7.5
Iron Workers (Ornamental).....	22.4 to 23.0
Cement Masons.....	23.0 to 27.0
Glaziers.....	16.0 to 20.0
Plasterers.....	15.8 to 18.0
Teamsters.....	22.0 to 22.5
Boilermakers.....	13.0 to 15.5
All Others.....	16.4 to 17.5

GOALS FOR WOMEN

Female Goals - 6.9%

Goals for the utilization of women by Federal and Federally assisted construction contractors were last published on April 7, 1978 (43 CFR 4988, 149000). That April 7, 1978 publication included a 6.9% goal for the period from April 1, 1980 until March 31, 1981. Pursuant to 41 CFR 60-4.6, the 6.9% goal for female utilization is extended until further notice

REQUIRED CONTRACT PROVISIONS FEDERAL-AID CONSTRUCTION CONTRACTS

- I. General
- II. Nondiscrimination
- III. Nonsegregated Facilities
- IV. Davis-Bacon and Related Act Provisions
- V. Contract Work Hours and Safety Standards Act Provisions
- VI. Subletting or Assigning the Contract
- VII. Safety: Accident Prevention
- VIII. False Statements Concerning Highway Projects
- IX. Implementation of Clean Air Act and Federal Water Pollution Control Act
- X. Compliance with Governmentwide Suspension and Debarment Requirements
- XI. Certification Regarding Use of Contract Funds for Lobbying

ATTACHMENTS

A. Employment and Materials Preference for Appalachian Development Highway System or Appalachian Local Access Road Contracts (included in Appalachian contracts only)

I. GENERAL

1. Form FHWA-1273 must be physically incorporated in each construction contract funded under Title 23 (excluding emergency contracts solely intended for debris removal). The contractor (or subcontractor) must insert this form in each subcontract and further require its inclusion in all lower tier subcontracts (excluding purchase orders, rental agreements and other agreements for supplies or services).

The applicable requirements of Form FHWA-1273 are incorporated by reference for work done under any purchase order, rental agreement or agreement for other services. The prime contractor shall be responsible for compliance by any subcontractor, lower-tier subcontractor or service provider.

Form FHWA-1273 must be included in all Federal-aid design-build contracts, in all subcontracts and in lower tier subcontracts (excluding subcontracts for design services, purchase orders, rental agreements and other agreements for supplies or services). The design-builder shall be responsible for compliance by any subcontractor, lower-tier subcontractor or service provider.

Contracting agencies may reference Form FHWA-1273 in bid proposal or request for proposal documents, however, the Form FHWA-1273 must be physically incorporated (not referenced) in all contracts, subcontracts and lower-tier subcontracts (excluding purchase orders, rental agreements and other agreements for supplies or services related to a construction contract).

2. Subject to the applicability criteria noted in the following sections, these contract provisions shall apply to all work performed on the contract by the contractor's own organization and with the assistance of workers under the contractor's immediate superintendence and to all work performed on the contract by piecework, station work, or by subcontract.

3. A breach of any of the stipulations contained in these Required Contract Provisions may be sufficient grounds for withholding of progress payments, withholding of final payment, termination of the contract, suspension / debarment or any other action determined to be appropriate by the contracting agency and FHWA.

4. Selection of Labor: During the performance of this contract, the contractor shall not use convict labor

for any purpose within the limits of a construction project on a Federal-aid highway unless it is labor performed by convicts who are on parole, supervised release, or probation. The term Federal-aid highway does not include roadways functionally classified as local roads or rural minor collectors.

II. NONDISCRIMINATION

The provisions of this section related to 23 CFR Part 230 are applicable to all Federal-aid construction contracts and to all related construction subcontracts of \$10,000 or more. The provisions of 23 CFR Part 230 are not applicable to material supply, engineering, or architectural service contracts.

In addition, the contractor and all subcontractors must comply with the following policies: Executive Order 11246, 41 CFR 60, 29 CFR 1625-1627, Title 23 USC Section 140, the Rehabilitation Act of 1973, as amended (29 USC 794), Title VI of the Civil Rights Act of 1964, as amended, and related regulations including 49 CFR Parts 21, 26 and 27; and 23 CFR Parts 200, 230, and 633.

The contractor and all subcontractors must comply with: the requirements of the Equal Opportunity Clause in 41 CFR 60-1.4(b) and, for all construction contracts exceeding \$10,000, the Standard Federal Equal Employment Opportunity Construction Contract Specifications in 41 CFR 60-4.3.

Note: The U.S. Department of Labor has exclusive authority to determine compliance with Executive Order 11246 and the policies of the Secretary of Labor including 41 CFR 60, and 29 CFR 1625-1627. The contracting agency and the FHWA have the authority and the responsibility to ensure compliance with Title 23 USC Section 140, the Rehabilitation Act of 1973, as amended (29 USC 794), and Title VI of the Civil Rights Act of 1964, as amended, and related regulations including 49 CFR Parts 21, 26 and 27; and 23 CFR Parts 200, 230, and 633.

The following provision is adopted from 23 CFR 230, Appendix A, with appropriate revisions to conform to the U.S. Department of Labor (US DOL) and FHWA requirements.

1. Equal Employment Opportunity: Equal employment opportunity (EEO) requirements not to discriminate and to take affirmative action to assure equal opportunity as set forth under laws, executive orders, rules, regulations (28 CFR 35, 29 CFR 1630, 29 CFR 1625-1627, 41 CFR 60 and 49 CFR 27) and orders of the Secretary of Labor as modified by the provisions prescribed herein, and imposed pursuant to 23 U.S.C. 140 shall constitute the EEO and specific affirmative action standards for the contractor's project activities under this contract. The provisions of the Americans with Disabilities Act of 1990 (42 U.S.C. 12101 et seq.) set forth under 28 CFR 35 and 29 CFR 1630 are incorporated by reference in this contract. In the execution of this contract, the contractor agrees to comply with the following minimum specific requirement activities of EEO:

a. The contractor will work with the contracting agency and the Federal Government to ensure that it has made every good faith effort to provide equal opportunity with respect to all of its terms and conditions of employment and in their review of activities under the contract.

b. The contractor will accept as its operating policy the following statement:

"It is the policy of this Company to assure that applicants are employed, and that employees are treated during employment, without regard to their race, religion, sex, color, national origin, age or disability. Such action shall include: employment, upgrading, demotion, or transfer; recruitment or recruitment advertising; layoff or termination; rates of pay or other forms of compensation; and selection for training, including apprenticeship, pre-apprenticeship, and/or on-the-job training."

2. EEO Officer: The contractor will designate and make known to the contracting officers an EEO Officer who will have the responsibility for and must be capable of effectively administering and promoting an active EEO program and who must be assigned adequate authority and responsibility to do so.

3. Dissemination of Policy: All members of the contractor's staff who are authorized to hire, supervise, promote, and discharge employees, or who recommend such action, or who are substantially involved in such action, will be made fully cognizant of, and will implement, the contractor's EEO policy and contractual responsibilities to provide EEO in each grade and classification of employment. To ensure that the above agreement will be met, the following actions will be taken as a minimum:

a. Periodic meetings of supervisory and personnel office employees will be conducted before the start of work and then not less often than once every six months, at which time the contractor's EEO policy and its implementation will be reviewed and explained. The meetings will be conducted by the EEO Officer.

b. All new supervisory or personnel office employees will be given a thorough indoctrination by the EEO Officer, covering all major aspects of the contractor's EEO obligations within thirty days following their reporting for duty with the contractor.

c. All personnel who are engaged in direct recruitment for the project will be instructed by the EEO Officer in the contractor's procedures for locating and hiring minorities and women.

d. Notices and posters setting forth the contractor's EEO policy will be placed in areas readily accessible to employees, applicants for employment and potential employees.

e. The contractor's EEO policy and the procedures to implement such policy will be brought to the attention of employees by means of meetings, employee handbooks, or other appropriate means.

4. Recruitment: When advertising for employees, the contractor will include in all advertisements for employees the notation: "An Equal Opportunity Employer." All such advertisements will be placed in publications having a large circulation among minorities and women in the area from which the project work force would normally be derived.

a. The contractor will, unless precluded by a valid bargaining agreement, conduct systematic and direct recruitment through public and private employee referral sources likely to yield qualified minorities and women. To meet this requirement, the contractor will identify sources of potential minority group employees, and establish with such identified sources procedures whereby minority and women applicants may be referred to the contractor for employment consideration.

b. In the event the contractor has a valid bargaining agreement providing for exclusive hiring hall referrals, the contractor is expected to observe the provisions of that agreement to the extent that the system meets the contractor's compliance with EEO contract provisions. Where implementation of such an agreement has the effect of discriminating against minorities or women, or obligates the contractor to do the same, such implementation violates Federal nondiscrimination provisions.

c. The contractor will encourage its present employees to refer minorities and women as applicants for employment. Information and procedures with regard to referring such applicants will be discussed with employees.

5. Personnel Actions: Wages, working conditions, and employee benefits shall be established and administered, and personnel actions of every type, including hiring, upgrading, promotion, transfer, demotion, layoff, and termination, shall be taken without regard to race, color, religion, sex, national origin, age or disability. The following procedures shall be followed:

- a. The contractor will conduct periodic inspections of project sites to insure that working conditions and employee facilities do not indicate discriminatory treatment of project site personnel.
- b. The contractor will periodically evaluate the spread of wages paid within each classification to determine any evidence of discriminatory wage practices.
- c. The contractor will periodically review selected personnel actions in depth to determine whether there is evidence of discrimination. Where evidence is found, the contractor will promptly take corrective action. If the review indicates that the discrimination may extend beyond the actions reviewed, such corrective action shall include all affected persons.
- d. The contractor will promptly investigate all complaints of alleged discrimination made to the contractor in connection with its obligations under this contract, will attempt to resolve such complaints, and will take appropriate corrective action within a reasonable time. If the investigation indicates that the discrimination may affect persons other than the complainant, such corrective action shall include such other persons. Upon completion of each investigation, the contractor will inform every complainant of all of their avenues of appeal.

6. Training and Promotion:

- a. The contractor will assist in locating, qualifying, and increasing the skills of minorities and women who are applicants for employment or current employees. Such efforts should be aimed at developing full journey level status employees in the type of trade or job classification involved.
- b. Consistent with the contractor's work force requirements and as permissible under Federal and State regulations, the contractor shall make full use of training programs, i.e., apprenticeship, and on-the-job training programs for the geographical area of contract performance. In the event a special provision for training is provided under this contract, this subparagraph will be superseded as indicated in the special provision. The contracting agency may reserve training positions for persons who receive welfare assistance in accordance with 23 U.S.C. 140(a).
- c. The contractor will advise employees and applicants for employment of available training programs and entrance requirements for each.
- d. The contractor will periodically review the training and promotion potential of employees who are minorities and women and will encourage eligible employees to apply for such training and promotion.

7. Unions: If the contractor relies in whole or in part upon unions as a source of employees, the contractor will use good faith efforts to obtain the cooperation of such unions to increase opportunities for minorities and women. Actions by the contractor, either directly or through a contractor's association acting as agent, will include the procedures set forth below:

- a. The contractor will use good faith efforts to develop, in cooperation with the unions, joint training programs aimed toward qualifying more minorities and women for membership in the unions and increasing the skills of minorities and women so that they may qualify for higher paying employment.

b. The contractor will use good faith efforts to incorporate an EEO clause into each union agreement to the end that such union will be contractually bound to refer applicants without regard to their race, color, religion, sex, national origin, age or disability.

c. The contractor is to obtain information as to the referral practices and policies of the labor union except that to the extent such information is within the exclusive possession of the labor union and such labor union refuses to furnish such information to the contractor, the contractor shall so certify to the contracting agency and shall set forth what efforts have been made to obtain such information.

d. In the event the union is unable to provide the contractor with a reasonable flow of referrals within the time limit set forth in the collective bargaining agreement, the contractor will, through independent recruitment efforts, fill the employment vacancies without regard to race, color, religion, sex, national origin, age or disability; making full efforts to obtain qualified and/or qualifiable minorities and women. The failure of a union to provide sufficient referrals (even though it is obligated to provide exclusive referrals under the terms of a collective bargaining agreement) does not relieve the contractor from the requirements of this paragraph. In the event the union referral practice prevents the contractor from meeting the obligations pursuant to Executive Order 11246, as amended, and these special provisions, such contractor shall immediately notify the contracting agency.

8. Reasonable Accommodation for Applicants / Employees with Disabilities: The contractor must be familiar with the requirements for and comply with the Americans with Disabilities Act and all rules and regulations established there under. Employers must provide reasonable accommodation in all employment activities unless to do so would cause an undue hardship.

9. Selection of Subcontractors, Procurement of Materials and Leasing of Equipment: The contractor shall not discriminate on the grounds of race, color, religion, sex, national origin, age or disability in the selection and retention of subcontractors, including procurement of materials and leases of equipment. The contractor shall take all necessary and reasonable steps to ensure nondiscrimination in the administration of this contract.

a. The contractor shall notify all potential subcontractors and suppliers and lessors of their EEO obligations under this contract.

b. The contractor will use good faith efforts to ensure subcontractor compliance with their EEO obligations.

10. Assurance Required by 49 CFR 26.13(b):

a. The requirements of 49 CFR Part 26 and the State DOT's U.S. DOT-approved DBE program are incorporated by reference.

b. The contractor or subcontractor shall not discriminate on the basis of race, color, national origin, or sex in the performance of this contract. The contractor shall carry out applicable requirements of 49 CFR Part 26 in the award and administration of DOT-assisted contracts. Failure by the contractor to carry out these requirements is a material breach of this contract, which may result in the termination of this contract or such other remedy as the contracting agency deems appropriate.

11. Records and Reports: The contractor shall keep such records as necessary to document compliance with the EEO requirements. Such records shall be retained for a period of three years following the date

of the final payment to the contractor for all contract work and shall be available at reasonable times and places for inspection by authorized representatives of the contracting agency and the FHWA.

a. The records kept by the contractor shall document the following:

(1) The number and work hours of minority and non-minority group members and women employed in each work classification on the project;

(2) The progress and efforts being made in cooperation with unions, when applicable, to increase employment opportunities for minorities and women; and

(3) The progress and efforts being made in locating, hiring, training, qualifying, and upgrading minorities and women;

b. The contractors and subcontractors will submit an annual report to the contracting agency each July for the duration of the project, indicating the number of minority, women, and non-minority group employees currently engaged in each work classification required by the contract work. This information is to be reported on [Form FHWA-1391](#). The staffing data should represent the project work force on board in all or any part of the last payroll period preceding the end of July. If on-the-job training is being required by special provision, the contractor will be required to collect and report training data. The employment data should reflect the work force on board during all or any part of the last payroll period preceding the end of July.

III. NONSEGREGATED FACILITIES

This provision is applicable to all Federal-aid construction contracts and to all related construction subcontracts of \$10,000 or more.

The contractor must ensure that facilities provided for employees are provided in such a manner that segregation on the basis of race, color, religion, sex, or national origin cannot result. The contractor may neither require such segregated use by written or oral policies nor tolerate such use by employee custom. The contractor's obligation extends further to ensure that its employees are not assigned to perform their services at any location, under the contractor's control, where the facilities are segregated. The term "facilities" includes waiting rooms, work areas, restaurants and other eating areas, time clocks, restrooms, washrooms, locker rooms, and other storage or dressing areas, parking lots, drinking fountains, recreation or entertainment areas, transportation, and housing provided for employees. The contractor shall provide separate or single-user restrooms and necessary dressing or sleeping areas to assure privacy between sexes.

IV. DAVIS-BACON AND RELATED ACT PROVISIONS

This section is applicable to all Federal-aid construction projects exceeding \$2,000 and to all related subcontracts and lower-tier subcontracts (regardless of subcontract size). The requirements apply to all projects located within the right-of-way of a roadway that is functionally classified as Federal-aid highway. This excludes roadways functionally classified as local roads or rural minor collectors, which are exempt. Contracting agencies may elect to apply these requirements to other projects.

The following provisions are from the U.S. Department of Labor regulations in 29 CFR 5.5 "Contract provisions and related matters" with minor revisions to conform to the FHWA-1273 format and FHWA program requirements.

1. Minimum wages

a. All laborers and mechanics employed or working upon the site of the work, will be paid unconditionally and not less often than once a week, and without subsequent deduction or rebate on any account (except such payroll deductions as are permitted by regulations issued by the Secretary of Labor under the Copeland Act (29 CFR part 3)), the full amount of wages and bona fide fringe benefits (or cash equivalents thereof) due at time of payment computed at rates not less than those contained in the wage determination of the Secretary of Labor which is attached hereto and made a part hereof, regardless of any contractual relationship which may be alleged to exist between the contractor and such laborers and mechanics.

Contributions made or costs reasonably anticipated for bona fide fringe benefits under section 1(b)(2) of the Davis-Bacon Act on behalf of laborers or mechanics are considered wages paid to such laborers or mechanics, subject to the provisions of paragraph 1.d. of this section; also, regular contributions made or costs incurred for more than a weekly period (but not less often than quarterly) under plans, funds, or programs which cover the particular weekly period, are deemed to be constructively made or incurred during such weekly period. Such laborers and mechanics shall be paid the appropriate wage rate and fringe benefits on the wage determination for the classification of work actually performed, without regard to skill, except as provided in 29 CFR 5.5(a)(4). Laborers or mechanics performing work in more than one classification may be compensated at the rate specified for each classification for the time actually worked therein: Provided, That the employer's payroll records accurately set forth the time spent in each classification in which work is performed. The wage determination (including any additional classification and wage rates conformed under paragraph 1.b. of this section) and the Davis-Bacon poster (WH-1321) shall be posted at all times by the contractor and its subcontractors at the site of the work in a prominent and accessible place where it can be easily seen by the workers.

b. (1) The contracting officer shall require that any class of laborers or mechanics, including helpers, which is not listed in the wage determination and which is to be employed under the contract shall be classified in conformance with the wage determination. The contracting officer shall approve an additional classification and wage rate and fringe benefits therefore only when the following criteria have been met:

(i) The work to be performed by the classification requested is not performed by a classification in the wage determination; and

(ii) The classification is utilized in the area by the construction industry; and

(iii) The proposed wage rate, including any bona fide fringe benefits, bears a reasonable relationship to the wage rates contained in the wage determination.

(2) If the contractor and the laborers and mechanics to be employed in the classification (if known), or their representatives, and the contracting officer agree on the classification and wage rate (including the amount designated for fringe benefits where appropriate), a report of the action taken shall be sent by the contracting officer to the Administrator of the Wage and Hour Division, Employment Standards Administration, U.S. Department of Labor, Washington, DC 20210. The Administrator, or an authorized representative, will approve, modify, or disapprove every additional classification action within 30 days of receipt and so advise the contracting officer or will notify the contracting officer within the 30-day period that additional time is necessary.

(3) In the event the contractor, the laborers or mechanics to be employed in the classification or their representatives, and the contracting officer do not agree on the proposed classification and wage rate (including the amount designated for fringe benefits, where appropriate), the contracting officer shall refer the questions, including the views of all interested parties and the recommendation of the contracting officer, to the Wage and Hour Administrator for determination. The Wage and Hour Administrator, or an authorized representative, will issue a determination within 30 days of receipt and so advise the contracting officer or will notify the contracting officer within the 30-day period that additional time is necessary.

(4) The wage rate (including fringe benefits where appropriate) determined pursuant to paragraphs 1.b.(2) or 1.b.(3) of this section, shall be paid to all workers performing work in the classification under this contract from the first day on which work is performed in the classification.

c. Whenever the minimum wage rate prescribed in the contract for a class of laborers or mechanics includes a fringe benefit which is not expressed as an hourly rate, the contractor shall either pay the benefit as stated in the wage determination or shall pay another bona fide fringe benefit or an hourly cash equivalent thereof.

d. If the contractor does not make payments to a trustee or other third person, the contractor may consider as part of the wages of any laborer or mechanic the amount of any costs reasonably anticipated in providing bona fide fringe benefits under a plan or program, Provided, That the Secretary of Labor has found, upon the written request of the contractor, that the applicable standards of the Davis-Bacon Act have been met. The Secretary of Labor may require the contractor to set aside in a separate account assets for the meeting of obligations under the plan or program.

2. Withholding

The contracting agency shall upon its own action or upon written request of an authorized representative of the Department of Labor, withhold or cause to be withheld from the contractor under this contract, or any other Federal contract with the same prime contractor, or any other federally-assisted contract subject to Davis-Bacon prevailing wage requirements, which is held by the same prime contractor, so much of the accrued payments or advances as may be considered necessary to pay laborers and mechanics, including apprentices, trainees, and helpers, employed by the contractor or any subcontractor the full amount of wages required by the contract. In the event of failure to pay any laborer or mechanic, including any apprentice, trainee, or helper, employed or working on the site of the work, all or part of the wages required by the contract, the contracting agency may, after written notice to the contractor, take such action as may be necessary to cause the suspension of any further payment, advance, or guarantee of funds until such violations have ceased.

3. Payrolls and basic records

a. Payrolls and basic records relating thereto shall be maintained by the contractor during the course of the work and preserved for a period of three years thereafter for all laborers and mechanics working at the site of the work. Such records shall contain the name, address, and social security number of each such worker, his or her correct classification, hourly rates of wages paid (including rates of contributions or costs anticipated for bona fide fringe benefits or cash equivalents thereof of the types described in section 1(b)(2)(B) of the Davis-Bacon Act), daily and weekly number of hours worked, deductions made and actual wages paid. Whenever the Secretary of Labor has found under 29 CFR 5.5(a)(1)(iv) that the wages of any laborer or mechanic include the amount of any costs reasonably anticipated in providing benefits under a plan or program described in section 1(b)(2)(B) of the Davis-Bacon Act, the contractor shall

maintain records which show that the commitment to provide such benefits is enforceable, that the plan or program is financially responsible, and that the plan or program has been communicated in writing to the laborers or mechanics affected, and records which show the costs anticipated or the actual cost incurred in providing such benefits. Contractors employing apprentices or trainees under approved programs shall maintain written evidence of the registration of apprenticeship programs and certification of trainee programs, the registration of the apprentices and trainees, and the ratios and wage rates prescribed in the applicable programs.

b. (1) The contractor shall submit weekly for each week in which any contract work is performed a copy of all payrolls to the contracting agency. The payrolls submitted shall set out accurately and completely all of the information required to be maintained under 29 CFR 5.5(a)(3)(i), except that full social security numbers and home addresses shall not be included on weekly transmittals. Instead the payrolls shall only need to include an individually identifying number for each employee (e.g. , the last four digits of the employee's social security number). The required weekly payroll information may be submitted in any form desired. Optional Form WH-347 is available for this purpose from the Wage and Hour Division Web site at <http://www.dol.gov/esa/whd/forms/wh347instr.htm> or its successor site. The prime contractor is responsible for the submission of copies of payrolls by all subcontractors. Contractors and subcontractors shall maintain the full social security number and current address of each covered worker, and shall provide them upon request to the contracting agency for transmission to the State DOT, the FHWA or the Wage and Hour Division of the Department of Labor for purposes of an investigation or audit of compliance with prevailing wage requirements. It is not a violation of this section for a prime contractor to require a subcontractor to provide addresses and social security numbers to the prime contractor for its own records, without weekly submission to the contracting agency..

(2) Each payroll submitted shall be accompanied by a “Statement of Compliance,” signed by the contractor or subcontractor or his or her agent who pays or supervises the payment of the persons employed under the contract and shall certify the following:

(i) That the payroll for the payroll period contains the information required to be provided under §5.5(a)(3)(ii) of Regulations, 29 CFR part 5, the appropriate information is being maintained under §5.5(a)(3)(i) of Regulations, 29 CFR part 5, and that such information is correct and complete;

(ii) That each laborer or mechanic (including each helper, apprentice, and trainee) employed on the contract during the payroll period has been paid the full weekly wages earned, without rebate, either directly or indirectly, and that no deductions have been made either directly or indirectly from the full wages earned, other than permissible deductions as set forth in Regulations, 29 CFR part 3;

(iii) That each laborer or mechanic has been paid not less than the applicable wage rates and fringe benefits or cash equivalents for the classification of work performed, as specified in the applicable wage determination incorporated into the contract.

(3) The weekly submission of a properly executed certification set forth on the reverse side of Optional Form WH-347 shall satisfy the requirement for submission of the “Statement of Compliance” required by paragraph 3.b.(2) of this section.

(4) The falsification of any of the above certifications may subject the contractor or subcontractor to civil or criminal prosecution under section 1001 of title 18 and section 231 of title 31 of the United States Code.

c. The contractor or subcontractor shall make the records required under paragraph 3.a. of this section available for inspection, copying, or transcription by authorized representatives of the contracting agency, the State DOT, the FHWA, or the Department of Labor, and shall permit such representatives to interview employees during working hours on the job. If the contractor or subcontractor fails to submit the required records or to make them available, the FHWA may, after written notice to the contractor, the contracting agency or the State DOT, take such action as may be necessary to cause the suspension of any further payment, advance, or guarantee of funds. Furthermore, failure to submit the required records upon request or to make such records available may be grounds for debarment action pursuant to 29 CFR 5.12.

4. Apprentices and trainees

a. Apprentices (programs of the USDOL).

Apprentices will be permitted to work at less than the predetermined rate for the work they performed when they are employed pursuant to and individually registered in a bona fide apprenticeship program registered with the U.S. Department of Labor, Employment and Training Administration, Office of Apprenticeship Training, Employer and Labor Services, or with a State Apprenticeship Agency recognized by the Office, or if a person is employed in his or her first 90 days of probationary employment as an apprentice in such an apprenticeship program, who is not individually registered in the program, but who has been certified by the Office of Apprenticeship Training, Employer and Labor Services or a State Apprenticeship Agency (where appropriate) to be eligible for probationary employment as an apprentice.

The allowable ratio of apprentices to journeymen on the job site in any craft classification shall not be greater than the ratio permitted to the contractor as to the entire work force under the registered program. Any worker listed on a payroll at an apprentice wage rate, who is not registered or otherwise employed as stated above, shall be paid not less than the applicable wage rate on the wage determination for the classification of work actually performed. In addition, any apprentice performing work on the job site in excess of the ratio permitted under the registered program shall be paid not less than the applicable wage rate on the wage determination for the work actually performed. Where a contractor is performing construction on a project in a locality other than that in which its program is registered, the ratios and wage rates (expressed in percentages of the journeyman's hourly rate) specified in the contractor's or subcontractor's registered program shall be observed.

Every apprentice must be paid at not less than the rate specified in the registered program for the apprentice's level of progress, expressed as a percentage of the journeymen hourly rate specified in the applicable wage determination. Apprentices shall be paid fringe benefits in accordance with the provisions of the apprenticeship program. If the apprenticeship program does not specify fringe benefits, apprentices must be paid the full amount of fringe benefits listed on the wage determination for the applicable classification. If the Administrator determines that a different practice prevails for the applicable apprentice classification, fringes shall be paid in accordance with that determination.

In the event the Office of Apprenticeship Training, Employer and Labor Services, or a State Apprenticeship Agency recognized by the Office, withdraws approval of an apprenticeship program, the contractor will no longer be permitted to utilize apprentices at less than the applicable predetermined rate for the work performed until an acceptable program is approved.

b. Trainees (programs of the USDOL).

Except as provided in 29 CFR 5.16, trainees will not be permitted to work at less than the predetermined rate for the work performed unless they are employed pursuant to and individually registered in a program which has received prior approval, evidenced by formal certification by the U.S. Department of Labor, Employment and Training Administration.

The ratio of trainees to journeymen on the job site shall not be greater than permitted under the plan approved by the Employment and Training Administration.

Every trainee must be paid at not less than the rate specified in the approved program for the trainee's level of progress, expressed as a percentage of the journeyman hourly rate specified in the applicable wage determination. Trainees shall be paid fringe benefits in accordance with the provisions of the trainee program. If the trainee program does not mention fringe benefits, trainees shall be paid the full amount of fringe benefits listed on the wage determination unless the Administrator of the Wage and Hour Division determines that there is an apprenticeship program associated with the corresponding journeyman wage rate on the wage determination which provides for less than full fringe benefits for apprentices. Any employee listed on the payroll at a trainee rate who is not registered and participating in a training plan approved by the Employment and Training Administration shall be paid not less than the applicable wage rate on the wage determination for the classification of work actually performed. In addition, any trainee performing work on the job site in excess of the ratio permitted under the registered program shall be paid not less than the applicable wage rate on the wage determination for the work actually performed.

In the event the Employment and Training Administration withdraws approval of a training program, the contractor will no longer be permitted to utilize trainees at less than the applicable predetermined rate for the work performed until an acceptable program is approved.

c. Equal employment opportunity. The utilization of apprentices, trainees and journeymen under this part shall be in conformity with the equal employment opportunity requirements of Executive Order 11246, as amended, and 29 CFR part 30.

d. Apprentices and Trainees (programs of the U.S. DOT).

Apprentices and trainees working under apprenticeship and skill training programs which have been certified by the Secretary of Transportation as promoting EEO in connection with Federal-aid highway construction programs are not subject to the requirements of paragraph 4 of this Section IV. The straight time hourly wage rates for apprentices and trainees under such programs will be established by the particular programs. The ratio of apprentices and trainees to journeymen shall not be greater than permitted by the terms of the particular program.

5. Compliance with Copeland Act requirements. The contractor shall comply with the requirements of 29 CFR part 3, which are incorporated by reference in this contract.

6. Subcontracts. The contractor or subcontractor shall insert Form FHWA-1273 in any subcontracts and also require the subcontractors to include Form FHWA-1273 in any lower tier subcontracts. The prime contractor shall be responsible for the compliance by any subcontractor or lower tier subcontractor with all the contract clauses in 29 CFR 5.5.

7. Contract termination: debarment. A breach of the contract clauses in 29 CFR 5.5 may be grounds for termination of the contract, and for debarment as a contractor and a subcontractor as provided in 29 CFR 5.12.

8. Compliance with Davis-Bacon and Related Act requirements. All rulings and interpretations of the Davis-Bacon and Related Acts contained in 29 CFR parts 1, 3, and 5 are herein incorporated by reference in this contract.

9. Disputes concerning labor standards. Disputes arising out of the labor standards provisions of this contract shall not be subject to the general disputes clause of this contract. Such disputes shall be resolved in accordance with the procedures of the Department of Labor set forth in 29 CFR parts 5, 6, and 7. Disputes within the meaning of this clause include disputes between the contractor (or any of its subcontractors) and the contracting agency, the U.S. Department of Labor, or the employees or their representatives.

10. Certification of eligibility.

a. By entering into this contract, the contractor certifies that neither it (nor he or she) nor any person or firm who has an interest in the contractor's firm is a person or firm ineligible to be awarded Government contracts by virtue of section 3(a) of the Davis-Bacon Act or 29 CFR 5.12(a)(1).

b. No part of this contract shall be subcontracted to any person or firm ineligible for award of a Government contract by virtue of section 3(a) of the Davis-Bacon Act or 29 CFR 5.12(a)(1).

c. The penalty for making false statements is prescribed in the U.S. Criminal Code, 18 U.S.C. 1001.

V. CONTRACT WORK HOURS AND SAFETY STANDARDS ACT

The following clauses apply to any Federal-aid construction contract in an amount in excess of \$100,000 and subject to the overtime provisions of the Contract Work Hours and Safety Standards Act. These clauses shall be inserted in addition to the clauses required by 29 CFR 5.5(a) or 29 CFR 4.6. As used in this paragraph, the terms laborers and mechanics include watchmen and guards.

1. Overtime requirements. No contractor or subcontractor contracting for any part of the contract work which may require or involve the employment of laborers or mechanics shall require or permit any such laborer or mechanic in any workweek in which he or she is employed on such work to work in excess of forty hours in such workweek unless such laborer or mechanic receives compensation at a rate not less than one and one-half times the basic rate of pay for all hours worked in excess of forty hours in such workweek.

2. Violation; liability for unpaid wages; liquidated damages. In the event of any violation of the clause set forth in paragraph (1.) of this section, the contractor and any subcontractor responsible therefor shall be liable for the unpaid wages. In addition, such contractor and subcontractor shall be liable to the United States (in the case of work done under contract for the District of Columbia or a territory, to such District or to such territory), for liquidated damages. Such liquidated damages shall be computed with respect to each individual laborer or mechanic, including watchmen and guards, employed in violation of the clause set forth in paragraph (1.) of this section, in the sum of \$10 for each calendar day on which such individual was required or permitted to work in excess of the standard workweek of forty hours without payment of the overtime wages required by the clause set forth in paragraph (1.) of this section.

3. Withholding for unpaid wages and liquidated damages. The FHWA or the contacting agency shall upon its own action or upon written request of an authorized representative of the Department of Labor withhold or cause to be withheld, from any moneys payable on account of work performed by the

contractor or subcontractor under any such contract or any other Federal contract with the same prime contractor, or any other federally-assisted contract subject to the Contract Work Hours and Safety Standards Act, which is held by the same prime contractor, such sums as may be determined to be necessary to satisfy any liabilities of such contractor or subcontractor for unpaid wages and liquidated damages as provided in the clause set forth in paragraph (2.) of this section.

4. Subcontracts. The contractor or subcontractor shall insert in any subcontracts the clauses set forth in paragraph (1.) through (4.) of this section and also a clause requiring the subcontractors to include these clauses in any lower tier subcontracts. The prime contractor shall be responsible for compliance by any subcontractor or lower tier subcontractor with the clauses set forth in paragraphs (1.) through (4.) of this section.

VI. SUBLETTING OR ASSIGNING THE CONTRACT

This provision is applicable to all Federal-aid construction contracts on the National Highway System.

1. The contractor shall perform with its own organization contract work amounting to not less than 30 percent (or a greater percentage if specified elsewhere in the contract) of the total original contract price, excluding any specialty items designated by the contracting agency. Specialty items may be performed by subcontract and the amount of any such specialty items performed may be deducted from the total original contract price before computing the amount of work required to be performed by the contractor's own organization (23 CFR 635.116).

a. The term "perform work with its own organization" refers to workers employed or leased by the prime contractor, and equipment owned or rented by the prime contractor, with or without operators. Such term does not include employees or equipment of a subcontractor or lower tier subcontractor, agents of the prime contractor, or any other assignees. The term may include payments for the costs of hiring leased employees from an employee leasing firm meeting all relevant Federal and State regulatory requirements. Leased employees may only be included in this term if the prime contractor meets all of the following conditions:

- (1) the prime contractor maintains control over the supervision of the day-to-day activities of the leased employees;
- (2) the prime contractor remains responsible for the quality of the work of the leased employees;
- (3) the prime contractor retains all power to accept or exclude individual employees from work on the project; and
- (4) the prime contractor remains ultimately responsible for the payment of predetermined minimum wages, the submission of payrolls, statements of compliance and all other Federal regulatory requirements.

b. "Specialty Items" shall be construed to be limited to work that requires highly specialized knowledge, abilities, or equipment not ordinarily available in the type of contracting organizations qualified and expected to bid or propose on the contract as a whole and in general are to be limited to minor components of the overall contract.

2. The contract amount upon which the requirements set forth in paragraph (1) of Section VI is computed includes the cost of material and manufactured products which are to be purchased or produced by the contractor under the contract provisions.

3. The contractor shall furnish (a) a competent superintendent or supervisor who is employed by the firm,

has full authority to direct performance of the work in accordance with the contract requirements, and is in charge of all construction operations (regardless of who performs the work) and (b) such other of its own organizational resources (supervision, management, and engineering services) as the contracting officer determines is necessary to assure the performance of the contract.

4. No portion of the contract shall be sublet, assigned or otherwise disposed of except with the written consent of the contracting officer, or authorized representative, and such consent when given shall not be construed to relieve the contractor of any responsibility for the fulfillment of the contract. Written consent will be given only after the contracting agency has assured that each subcontract is evidenced in writing and that it contains all pertinent provisions and requirements of the prime contract.

5. The 30% self-performance requirement of paragraph (1) is not applicable to design-build contracts; however, contracting agencies may establish their own self-performance requirements.

VII. SAFETY: ACCIDENT PREVENTION

This provision is applicable to all Federal-aid construction contracts and to all related subcontracts.

1. In the performance of this contract the contractor shall comply with all applicable Federal, State, and local laws governing safety, health, and sanitation (23 CFR 635). The contractor shall provide all safeguards, safety devices and protective equipment and take any other needed actions as it determines, or as the contracting officer may determine, to be reasonably necessary to protect the life and health of employees on the job and the safety of the public and to protect property in connection with the performance of the work covered by the contract.

2. It is a condition of this contract, and shall be made a condition of each subcontract, which the contractor enters into pursuant to this contract, that the contractor and any subcontractor shall not permit any employee, in performance of the contract, to work in surroundings or under conditions which are unsanitary, hazardous or dangerous to his/her health or safety, as determined under construction safety and health standards (29 CFR 1926) promulgated by the Secretary of Labor, in accordance with Section 107 of the Contract Work Hours and Safety Standards Act (40 U.S.C. 3704).

3. Pursuant to 29 CFR 1926.3, it is a condition of this contract that the Secretary of Labor or authorized representative thereof, shall have right of entry to any site of contract performance to inspect or investigate the matter of compliance with the construction safety and health standards and to carry out the duties of the Secretary under Section 107 of the Contract Work Hours and Safety Standards Act (40 U.S.C.3704).

VIII. FALSE STATEMENTS CONCERNING HIGHWAY PROJECTS

This provision is applicable to all Federal-aid construction contracts and to all related subcontracts.

In order to assure high quality and durable construction in conformity with approved plans and specifications and a high degree of reliability on statements and representations made by engineers, contractors, suppliers, and workers on Federal-aid highway projects, it is essential that all persons concerned with the project perform their functions as carefully, thoroughly, and honestly as possible. Willful falsification, distortion, or misrepresentation with respect to any facts related to the project is a violation of Federal law. To prevent any misunderstanding regarding the seriousness of these and similar acts, Form FHWA-1022 shall be posted on each Federal-aid highway project (23 CFR 635) in one or more places where it is readily available to all persons concerned with the project:

18 U.S.C. 1020 reads as follows:

"Whoever, being an officer, agent, or employee of the United States, or of any State or Territory, or whoever, whether a person, association, firm, or corporation, knowingly makes any false statement, false representation, or false report as to the character, quality, quantity, or cost of the material used or to be used, or the quantity or quality of the work performed or to be performed, or the cost thereof in connection with the submission of plans, maps, specifications, contracts, or costs of construction on any highway or related project submitted for approval to the Secretary of Transportation; or

Whoever knowingly makes any false statement, false representation, false report or false claim with respect to the character, quality, quantity, or cost of any work performed or to be performed, or materials furnished or to be furnished, in connection with the construction of any highway or related project approved by the Secretary of Transportation; or

Whoever knowingly makes any false statement or false representation as to material fact in any statement, certificate, or report submitted pursuant to provisions of the Federal-aid Roads Act approved July 1, 1916, (39 Stat. 355), as amended and supplemented;

Shall be fined under this title or imprisoned not more than 5 years or both."

IX. IMPLEMENTATION OF CLEAN AIR ACT AND FEDERAL WATER POLLUTION CONTROL ACT

This provision is applicable to all Federal-aid construction contracts and to all related subcontracts.

By submission of this bid/proposal or the execution of this contract, or subcontract, as appropriate, the bidder, proposer, Federal-aid construction contractor, or subcontractor, as appropriate, will be deemed to have stipulated as follows:

1. That any person who is or will be utilized in the performance of this contract is not prohibited from receiving an award due to a violation of Section 508 of the Clean Water Act or Section 306 of the Clean Air Act.
2. That the contractor agrees to include or cause to be included the requirements of paragraph (1) of this Section X in every subcontract, and further agrees to take such action as the contracting agency may direct as a means of enforcing such requirements.

X. CERTIFICATION REGARDING DEBARMENT, SUSPENSION, INELIGIBILITY AND VOLUNTARY EXCLUSION

This provision is applicable to all Federal-aid construction contracts, design-build contracts, subcontracts, lower-tier subcontracts, purchase orders, lease agreements, consultant contracts or any other covered transaction requiring FHWA approval or that is estimated to cost \$25,000 or more – as defined in 2 CFR Parts 180 and 1200.

1. Instructions for Certification – First Tier Participants:

- a. By signing and submitting this proposal, the prospective first tier participant is providing the

certification set out below.

b. The inability of a person to provide the certification set out below will not necessarily result in denial of participation in this covered transaction. The prospective first tier participant shall submit an explanation of why it cannot provide the certification set out below. The certification or explanation will be considered in connection with the department or agency's determination whether to enter into this transaction. However, failure of the prospective first tier participant to furnish a certification or an explanation shall disqualify such a person from participation in this transaction.

c. The certification in this clause is a material representation of fact upon which reliance was placed when the contracting agency determined to enter into this transaction. If it is later determined that the prospective participant knowingly rendered an erroneous certification, in addition to other remedies available to the Federal Government, the contracting agency may terminate this transaction for cause of default.

d. The prospective first tier participant shall provide immediate written notice to the contracting agency to whom this proposal is submitted if any time the prospective first tier participant learns that its certification was erroneous when submitted or has become erroneous by reason of changed circumstances.

e. The terms "covered transaction," "debarred," "suspended," "ineligible," "participant," "person," "principal," and "voluntarily excluded," as used in this clause, are defined in 2 CFR Parts 180 and 1200. "First Tier Covered Transactions" refers to any covered transaction between a grantee or subgrantee of Federal funds and a participant (such as the prime or general contract). "Lower Tier Covered Transactions" refers to any covered transaction under a First Tier Covered Transaction (such as subcontracts). "First Tier Participant" refers to the participant who has entered into a covered transaction with a grantee or subgrantee of Federal funds (such as the prime or general contractor). "Lower Tier Participant" refers any participant who has entered into a covered transaction with a First Tier Participant or other Lower Tier Participants (such as subcontractors and suppliers).

f. The prospective first tier participant agrees by submitting this proposal that, should the proposed covered transaction be entered into, it shall not knowingly enter into any lower tier covered transaction with a person who is debarred, suspended, declared ineligible, or voluntarily excluded from participation in this covered transaction, unless authorized by the department or agency entering into this transaction.

g. The prospective first tier participant further agrees by submitting this proposal that it will include the clause titled "Certification Regarding Debarment, Suspension, Ineligibility and Voluntary Exclusion-Lower Tier Covered Transactions," provided by the department or contracting agency, entering into this covered transaction, without modification, in all lower tier covered transactions and in all solicitations for lower tier covered transactions exceeding the \$25,000 threshold.

h. A participant in a covered transaction may rely upon a certification of a prospective participant in a lower tier covered transaction that is not debarred, suspended, ineligible, or voluntarily excluded from the covered transaction, unless it knows that the certification is erroneous. A participant is responsible for ensuring that its principals are not suspended, debarred, or otherwise ineligible to participate in covered transactions. To verify the eligibility of its principals, as well as the eligibility of any lower tier prospective participants, each participant may, but is not required to, check the Excluded Parties List System website (<https://www.epls.gov/>), which is compiled by the General Services Administration.

i. Nothing contained in the foregoing shall be construed to require the establishment of a system of

records in order to render in good faith the certification required by this clause. The knowledge and information of the prospective participant is not required to exceed that which is normally possessed by a prudent person in the ordinary course of business dealings.

j. Except for transactions authorized under paragraph (f) of these instructions, if a participant in a covered transaction knowingly enters into a lower tier covered transaction with a person who is suspended, debarred, ineligible, or voluntarily excluded from participation in this transaction, in addition to other remedies available to the Federal Government, the department or agency may terminate this transaction for cause or default.

2. Certification Regarding Debarment, Suspension, Ineligibility and Voluntary Exclusion – First Tier Participants:

a. The prospective first tier participant certifies to the best of its knowledge and belief, that it and its principals:

(1) Are not presently debarred, suspended, proposed for debarment, declared ineligible, or voluntarily excluded from participating in covered transactions by any Federal department or agency;

(2) Have not within a three-year period preceding this proposal been convicted of or had a civil judgment rendered against them for commission of fraud or a criminal offense in connection with obtaining, attempting to obtain, or performing a public (Federal, State or local) transaction or contract under a public transaction; violation of Federal or State antitrust statutes or commission of embezzlement, theft, forgery, bribery, falsification or destruction of records, making false statements, or receiving stolen property;

(3) Are not presently indicted for or otherwise criminally or civilly charged by a governmental entity (Federal, State or local) with commission of any of the offenses enumerated in paragraph (a)(2) of this certification; and

(4) Have not within a three-year period preceding this application/proposal had one or more public transactions (Federal, State or local) terminated for cause or default.

b. Where the prospective participant is unable to certify to any of the statements in this certification, such prospective participant shall attach an explanation to this proposal.

2. Instructions for Certification - Lower Tier Participants:

(Applicable to all subcontracts, purchase orders and other lower tier transactions requiring prior FHWA approval or estimated to cost \$25,000 or more - 2 CFR Parts 180 and 1200)

a. By signing and submitting this proposal, the prospective lower tier is providing the certification set out below.

b. The certification in this clause is a material representation of fact upon which reliance was placed when this transaction was entered into. If it is later determined that the prospective lower tier participant knowingly rendered an erroneous certification, in addition to other remedies available to the Federal Government, the department, or agency with which this transaction originated may pursue available remedies, including suspension and/or debarment.

c. The prospective lower tier participant shall provide immediate written notice to the person to which

this proposal is submitted if at any time the prospective lower tier participant learns that its certification was erroneous by reason of changed circumstances.

d. The terms "covered transaction," "debarred," "suspended," "ineligible," "participant," "person," "principal," and "voluntarily excluded," as used in this clause, are defined in 2 CFR Parts 180 and 1200. You may contact the person to which this proposal is submitted for assistance in obtaining a copy of those regulations. "First Tier Covered Transactions" refers to any covered transaction between a grantee or subgrantee of Federal funds and a participant (such as the prime or general contract). "Lower Tier Covered Transactions" refers to any covered transaction under a First Tier Covered Transaction (such as subcontracts). "First Tier Participant" refers to the participant who has entered into a covered transaction with a grantee or subgrantee of Federal funds (such as the prime or general contractor). "Lower Tier Participant" refers any participant who has entered into a covered transaction with a First Tier Participant or other Lower Tier Participants (such as subcontractors and suppliers).

e. The prospective lower tier participant agrees by submitting this proposal that, should the proposed covered transaction be entered into, it shall not knowingly enter into any lower tier covered transaction with a person who is debarred, suspended, declared ineligible, or voluntarily excluded from participation in this covered transaction, unless authorized by the department or agency with which this transaction originated.

f. The prospective lower tier participant further agrees by submitting this proposal that it will include this clause titled "Certification Regarding Debarment, Suspension, Ineligibility and Voluntary Exclusion--Lower Tier Covered Transaction," without modification, in all lower tier covered transactions and in all solicitations for lower tier covered transactions exceeding the \$25,000 threshold.

g. A participant in a covered transaction may rely upon a certification of a prospective participant in a lower tier covered transaction that is not debarred, suspended, ineligible, or voluntarily excluded from the covered transaction, unless it knows that the certification is erroneous. A participant is responsible for ensuring that its principals are not suspended, debarred, or otherwise ineligible to participate in covered transactions. To verify the eligibility of its principals, as well as the eligibility of any lower tier prospective participants, each participant may, but is not required to, check the Excluded Parties List System website (<https://www.epls.gov/>), which is compiled by the General Services Administration.

h. Nothing contained in the foregoing shall be construed to require establishment of a system of records in order to render in good faith the certification required by this clause. The knowledge and information of participant is not required to exceed that which is normally possessed by a prudent person in the ordinary course of business dealings.

i. Except for transactions authorized under paragraph e of these instructions, if a participant in a covered transaction knowingly enters into a lower tier covered transaction with a person who is suspended, debarred, ineligible, or voluntarily excluded from participation in this transaction, in addition to other remedies available to the Federal Government, the department or agency with which this transaction originated may pursue available remedies, including suspension and/or debarment.

* * * * *

Certification Regarding Debarment, Suspension, Ineligibility and Voluntary Exclusion--Lower Tier Participants:

1. The prospective lower tier participant certifies, by submission of this proposal, that neither it nor its

principals is presently debarred, suspended, proposed for debarment, declared ineligible, or voluntarily excluded from participating in covered transactions by any Federal department or agency.

2. Where the prospective lower tier participant is unable to certify to any of the statements in this certification, such prospective participant shall attach an explanation to this proposal.

* * * * *

XI. CERTIFICATION REGARDING USE OF CONTRACT FUNDS FOR LOBBYING

This provision is applicable to all Federal-aid construction contracts and to all related subcontracts which exceed \$100,000 (49 CFR 20).

1. The prospective participant certifies, by signing and submitting this bid or proposal, to the best of his or her knowledge and belief, that:

a. No Federal appropriated funds have been paid or will be paid, by or on behalf of the undersigned, to any person for influencing or attempting to influence an officer or employee of any Federal agency, a Member of Congress, an officer or employee of Congress, or an employee of a Member of Congress in connection with the awarding of any Federal contract, the making of any Federal grant, the making of any Federal loan, the entering into of any cooperative agreement, and the extension, continuation, renewal, amendment, or modification of any Federal contract, grant, loan, or cooperative agreement.

b. If any funds other than Federal appropriated funds have been paid or will be paid to any person for influencing or attempting to influence an officer or employee of any Federal agency, a Member of Congress, an officer or employee of Congress, or an employee of a Member of Congress in connection with this Federal contract, grant, loan, or cooperative agreement, the undersigned shall complete and submit Standard Form-LLL, "Disclosure Form to Report Lobbying," in accordance with its instructions.

2. This certification is a material representation of fact upon which reliance was placed when this transaction was made or entered into. Submission of this certification is a prerequisite for making or entering into this transaction imposed by 31 U.S.C. 1352. Any person who fails to file the required certification shall be subject to a civil penalty of not less than \$10,000 and not more than \$100,000 for each such failure.

3. The prospective participant also agrees by submitting its bid or proposal that the participant shall require that the language of this certification be included in all lower tier subcontracts, which exceed \$100,000 and that all such recipients shall certify and disclose accordingly.

**ATTACHMENT A EMPLOYMENT AND MATERIALS PREFERENCE FOR APPALACHIAN
DEVELOPMENT HIGHWAY SYSTEM OR APPALACHIAN LOCAL ACCESS ROAD
CONTRACTS**

This provision is applicable to all Federal-aid projects funded under the Appalachian Regional Development Act of 1965.

1. During the performance of this contract, the contractor undertaking to do work which is, or reasonably may be, done as on-site work, shall give preference to qualified persons who regularly reside in the labor area as designated by the DOL wherein the contract work is situated, or the subregion, or the Appalachian counties of the State wherein the contract work is situated, except:

a. To the extent that qualified persons regularly residing in the area are not available.

b. For the reasonable needs of the contractor to employ supervisory or specially experienced personnel necessary to assure an efficient execution of the contract work.

c. For the obligation of the contractor to offer employment to present or former employees as the result of a lawful collective bargaining contract, provided that the number of nonresident persons employed under this subparagraph (1c) shall not exceed 20 percent of the total number of employees employed by the contractor on the contract work, except as provided in subparagraph (4) below.

2. The contractor shall place a job order with the State Employment Service indicating (a) the classifications of the laborers, mechanics and other employees required to perform the contract work, (b) the number of employees required in each classification, (c) the date on which the participant estimates such employees will be required, and (d) any other pertinent information required by the State Employment Service to complete the job order form. The job order may be placed with the State Employment Service in writing or by telephone. If during the course of the contract work, the information submitted by the contractor in the original job order is substantially modified, the participant shall promptly notify the State Employment Service.

3. The contractor shall give full consideration to all qualified job applicants referred to him by the State Employment Service. The contractor is not required to grant employment to any job applicants who, in his opinion, are not qualified to perform the classification of work required.

4. If, within one week following the placing of a job order by the contractor with the State Employment Service, the State Employment Service is unable to refer any qualified job applicants to the contractor, or less than the number requested, the State Employment Service will forward a certificate to the contractor indicating the unavailability of applicants. Such certificate shall be made a part of the contractor's permanent project records. Upon receipt of this certificate, the contractor may employ persons who do not normally reside in the labor area to fill positions covered by the certificate, notwithstanding the provisions of subparagraph (1c) above.

5. The provisions of 23 CFR 633.207(e) allow the contracting agency to provide a contractual preference for the use of mineral resource materials native to the Appalachian region.

6. The contractor shall include the provisions of Sections 1 through 4 of this Attachment A in every subcontract for work which is, or reasonably may be, done as on-site work.

APPENDIX A-1 SUPPLEMENTAL TITLE VI PROVISIONS (CIVIL RIGHTS ACT)

During the performance of this contract, the contractor, for itself, its assignees and successors in interest (hereinafter referred to as the "contractor") agrees as follows:

- (1) Compliance with Regulations: The contractor shall comply with the Regulation relative to nondiscrimination in Federally assisted programs of the Department of Transportation of the United States, Title 49, Code of Federal Regulations, Part 21, and the Federal Highway Administration (hereinafter "FHWA") Title 23, Code of Federal Regulations, Part 200 as they may be amended from time to time, (hereinafter referred to as the Regulations), which are herein incorporated by reference and made a part of this contract.
- (2) Nondiscrimination: The Contractor, with regard to the work performed by it during the contract, shall not discriminate on the grounds of race, religion, age, color, sex or national origin, sex, age, and disability/handicap in the selection and retention of subcontractors, including procurements of materials and leases of equipment. The contractor shall not participate either directly or indirectly in the discrimination prohibited by 49 CFR, section 21.5 of the Regulations, including employment practices when the contract covers a program set forth in Appendix B of the Regulations.
- (3) Solicitations for Subcontractors, Including Procurements of Materials and Equipment: In all solicitations either by competitive bidding or negotiation made by the contractor for work to be performed under a subcontract, including procurements of materials or leases of equipment, each potential subcontractor or supplier shall be notified by the contractor of the contractor's obligations under this contract and the Regulations relative to nondiscrimination on the grounds of race, color, or national origin, sex, age, and disability/handicap.
- (4) Information and Reports: The contractor shall provide all information and reports required by the Regulations or directives issued pursuant thereto, and shall permit access to its books, records, accounts, other sources of information, and its facilities as may be determined by NYSDOT or the FHWA to be pertinent to ascertain compliance with such Regulations, orders and instructions. Where any information required of a contractor is in the exclusive possession of another who fails or refuses to furnish this information the contractor shall so certify to NYSDOT's Office of Civil Rights or FHWA, as appropriate, and shall set forth what efforts it has made to obtain the information.
- (5) Sanctions for Noncompliance: In the event of the contractor's noncompliance with the nondiscrimination provisions of this contract, NYSDOT shall impose such contract sanctions as it or the FHWA may determine to be appropriate, including, but not limited to:
 - a) Withholding of payments to the contractor under the contract until the contractor complies; and/or
 - b) Cancellation, termination or suspension of the contract, in whole or in part.
- (6) Incorporation of Provisions: The contractor shall include the provisions of paragraphs (1) through (6) in every subcontract, including procurements of materials and leases of equipment, unless exempt by the Regulations, or directives issued pursuant thereto.

The contractor shall take such action with respect to any subcontractor procurement as NYSDOT or the FHWA may direct as a means of enforcing such provisions including sanctions for non-compliance: Provided, however, that in the event a contractor becomes involved in, or is threatened with, litigation with a subcontractor or supplier as a result of such direction, the contractor may request NYSDOT to enter into such litigation to protect the interests of NYSDOT, and, in addition, the contractor may request the United States to enter into such litigation to protect the interests of the United States.

**REQUIRED CONTRACT PROVISIONS
FEDERAL-AID CONSTRUCTION CONTRACTS**

- I. General
- II. Nondiscrimination
- III. Nonsegregated Facilities
- IV. Davis-Bacon and Related Act Provisions
- V. Contract Work Hours and Safety Standards Act Provisions
- VI. Subletting or Assigning the Contract
- VII. Safety: Accident Prevention
- VIII. False Statements Concerning Highway Projects
- IX. Implementation of Clean Air Act and Federal Water Pollution Control Act
- X. Compliance with Governmentwide Suspension and Debarment Requirements
- XI. Certification Regarding Use of Contract Funds for Lobbying

ATTACHMENTS

A. Employment and Materials Preference for Appalachian Development Highway System or Appalachian Local Access Road Contracts (included in Appalachian contracts only)

I. GENERAL

1. Form FHWA-1273 must be physically incorporated in each construction contract funded under Title 23 (excluding emergency contracts solely intended for debris removal). The contractor (or subcontractor) must insert this form in each subcontract and further require its inclusion in all lower tier subcontracts (excluding purchase orders, rental agreements and other agreements for supplies or services).

The applicable requirements of Form FHWA-1273 are incorporated by reference for work done under any purchase order, rental agreement or agreement for other services. The prime contractor shall be responsible for compliance by any subcontractor, lower-tier subcontractor or service provider.

Form FHWA-1273 must be included in all Federal-aid design-build contracts, in all subcontracts and in lower tier subcontracts (excluding subcontracts for design services, purchase orders, rental agreements and other agreements for supplies or services). The design-builder shall be responsible for compliance by any subcontractor, lower-tier subcontractor or service provider.

Contracting agencies may reference Form FHWA-1273 in bid proposal or request for proposal documents, however, the Form FHWA-1273 must be physically incorporated (not referenced) in all contracts, subcontracts and lower-tier subcontracts (excluding purchase orders, rental agreements and other agreements for supplies or services related to a construction contract).

2. Subject to the applicability criteria noted in the following sections, these contract provisions shall apply to all work performed on the contract by the contractor's own organization and with the assistance of workers under the contractor's immediate superintendence and to all work performed on the contract by piecework, station work, or by subcontract.

3. A breach of any of the stipulations contained in these Required Contract Provisions may be sufficient grounds for withholding of progress payments, withholding of final payment, termination of the contract, suspension / debarment or any other action determined to be appropriate by the contracting agency and FHWA.

4. Selection of Labor: During the performance of this contract, the contractor shall not use convict labor for any purpose within the limits of a construction project on a Federal-aid highway unless it is labor performed by convicts who are on parole, supervised release, or probation. The term Federal-aid highway does not include roadways functionally classified as local roads or rural minor collectors.

II. NONDISCRIMINATION

The provisions of this section related to 23 CFR Part 230 are applicable to all Federal-aid construction contracts and to all related construction subcontracts of \$10,000 or more. The provisions of 23 CFR Part 230 are not applicable to material supply, engineering, or architectural service contracts.

In addition, the contractor and all subcontractors must comply with the following policies: Executive Order 11246, 41 CFR 60, 29 CFR 1625-1627, Title 23 USC Section 140, the Rehabilitation Act of 1973, as amended (29 USC 794), Title VI of the Civil Rights Act of 1964, as amended, and related regulations including 49 CFR Parts 21, 26 and 27; and 23 CFR Parts 200, 230, and 633.

The contractor and all subcontractors must comply with: the requirements of the Equal Opportunity Clause in 41 CFR 60-1.4(b) and, for all construction contracts exceeding \$10,000, the Standard Federal Equal Employment Opportunity Construction Contract Specifications in 41 CFR 60-4.3.

Note: The U.S. Department of Labor has exclusive authority to determine compliance with Executive Order 11246 and the policies of the Secretary of Labor including 41 CFR 60, and 29 CFR 1625-1627. The contracting agency and the FHWA have the authority and the responsibility to ensure compliance with Title 23 USC Section 140, the Rehabilitation Act of 1973, as amended (29 USC 794), and Title VI of the Civil Rights Act of 1964, as amended, and related regulations including 49 CFR Parts 21, 26 and 27; and 23 CFR Parts 200, 230, and 633.

The following provision is adopted from 23 CFR 230, Appendix A, with appropriate revisions to conform to the U.S. Department of Labor (US DOL) and FHWA requirements.

1. Equal Employment Opportunity: Equal employment opportunity (EEO) requirements not to discriminate and to take affirmative action to assure equal opportunity as set forth under laws, executive orders, rules, regulations (28 CFR 35, 29 CFR 1630, 29 CFR 1625-1627, 41 CFR 60 and 49 CFR 27) and orders of the Secretary of Labor as modified by the provisions prescribed herein, and imposed pursuant to 23 U.S.C. 140 shall constitute the EEO and specific affirmative action standards for the contractor's project activities under

this contract. The provisions of the Americans with Disabilities Act of 1990 (42 U.S.C. 12101 et seq.) set forth under 28 CFR 35 and 29 CFR 1630 are incorporated by reference in this contract. In the execution of this contract, the contractor agrees to comply with the following minimum specific requirement activities of EEO:

a. The contractor will work with the contracting agency and the Federal Government to ensure that it has made every good faith effort to provide equal opportunity with respect to all of its terms and conditions of employment and in their review of activities under the contract.

b. The contractor will accept as its operating policy the following statement:

"It is the policy of this Company to assure that applicants are employed, and that employees are treated during employment, without regard to their race, religion, sex, color, national origin, age or disability. Such action shall include: employment, upgrading, demotion, or transfer; recruitment or recruitment advertising; layoff or termination; rates of pay or other forms of compensation; and selection for training, including apprenticeship, pre-apprenticeship, and/or on-the-job training."

2. EEO Officer: The contractor will designate and make known to the contracting officers an EEO Officer who will have the responsibility for and must be capable of effectively administering and promoting an active EEO program and who must be assigned adequate authority and responsibility to do so.

3. Dissemination of Policy: All members of the contractor's staff who are authorized to hire, supervise, promote, and discharge employees, or who recommend such action, or who are substantially involved in such action, will be made fully cognizant of, and will implement, the contractor's EEO policy and contractual responsibilities to provide EEO in each grade and classification of employment. To ensure that the above agreement will be met, the following actions will be taken as a minimum:

a. Periodic meetings of supervisory and personnel office employees will be conducted before the start of work and then not less often than once every six months, at which time the contractor's EEO policy and its implementation will be reviewed and explained. The meetings will be conducted by the EEO Officer.

b. All new supervisory or personnel office employees will be given a thorough indoctrination by the EEO Officer, covering all major aspects of the contractor's EEO obligations within thirty days following their reporting for duty with the contractor.

c. All personnel who are engaged in direct recruitment for the project will be instructed by the EEO Officer in the contractor's procedures for locating and hiring minorities and women.

d. Notices and posters setting forth the contractor's EEO policy will be placed in areas readily accessible to employees, applicants for employment and potential employees.

e. The contractor's EEO policy and the procedures to implement such policy will be brought to the attention of employees by means of meetings, employee handbooks, or other appropriate means.

4. Recruitment: When advertising for employees, the contractor will include in all advertisements for employees the notation: "An Equal Opportunity Employer." All such advertisements will be placed in publications having a large circulation among minorities and women in the area from which the project work force would normally be derived.

a. The contractor will, unless precluded by a valid bargaining agreement, conduct systematic and direct recruitment through public and private employee referral sources likely to yield qualified minorities and women. To meet this requirement, the contractor will identify sources of potential minority group employees, and establish with such identified sources procedures whereby minority and women applicants may be referred to the contractor for employment consideration.

b. In the event the contractor has a valid bargaining agreement providing for exclusive hiring hall referrals, the contractor is expected to observe the provisions of that agreement to the extent that the system meets the contractor's compliance with EEO contract provisions. Where implementation of such an agreement has the effect of discriminating against minorities or women, or obligates the contractor to do the same, such implementation violates Federal nondiscrimination provisions.

c. The contractor will encourage its present employees to refer minorities and women as applicants for employment. Information and procedures with regard to referring such applicants will be discussed with employees.

5. Personnel Actions: Wages, working conditions, and employee benefits shall be established and administered, and personnel actions of every type, including hiring, upgrading, promotion, transfer, demotion, layoff, and termination, shall be taken without regard to race, color, religion, sex, national origin, age or disability. The following procedures shall be followed:

a. The contractor will conduct periodic inspections of project sites to insure that working conditions and employee facilities do not indicate discriminatory treatment of project site personnel.

b. The contractor will periodically evaluate the spread of wages paid within each classification to determine any evidence of discriminatory wage practices.

c. The contractor will periodically review selected personnel actions in depth to determine whether there is evidence of discrimination. Where evidence is found, the contractor will promptly take corrective action. If the review indicates that the discrimination may extend beyond the actions reviewed, such corrective action shall include all affected persons.

d. The contractor will promptly investigate all complaints of alleged discrimination made to the contractor in connection with its obligations under this contract, will attempt to resolve such complaints, and will take appropriate corrective action within a reasonable time. If the investigation indicates that the discrimination may affect persons other than the complainant, such corrective action shall include such other persons. Upon completion of each investigation, the contractor will inform every complainant of all of their avenues of appeal.

6. Training and Promotion:

a. The contractor will assist in locating, qualifying, and increasing the skills of minorities and women who are

applicants for employment or current employees. Such efforts should be aimed at developing full journey level status employees in the type of trade or job classification involved.

b. Consistent with the contractor's work force requirements and as permissible under Federal and State regulations, the contractor shall make full use of training programs, i.e., apprenticeship, and on-the-job training programs for the geographical area of contract performance. In the event a special provision for training is provided under this contract, this subparagraph will be superseded as indicated in the special provision. The contracting agency may reserve training positions for persons who receive welfare assistance in accordance with 23 U.S.C. 140(a).

c. The contractor will advise employees and applicants for employment of available training programs and entrance requirements for each.

d. The contractor will periodically review the training and promotion potential of employees who are minorities and women and will encourage eligible employees to apply for such training and promotion.

7. Unions: If the contractor relies in whole or in part upon unions as a source of employees, the contractor will use good faith efforts to obtain the cooperation of such unions to increase opportunities for minorities and women. Actions by the contractor, either directly or through a contractor's association acting as agent, will include the procedures set forth below:

a. The contractor will use good faith efforts to develop, in cooperation with the unions, joint training programs aimed toward qualifying more minorities and women for membership in the unions and increasing the skills of minorities and women so that they may qualify for higher paying employment.

b. The contractor will use good faith efforts to incorporate an EEO clause into each union agreement to the end that such union will be contractually bound to refer applicants without regard to their race, color, religion, sex, national origin, age or disability.

c. The contractor is to obtain information as to the referral practices and policies of the labor union except that to the extent such information is within the exclusive possession of the labor union and such labor union refuses to furnish such information to the contractor, the contractor shall so certify to the contracting agency and shall set forth what efforts have been made to obtain such information.

d. In the event the union is unable to provide the contractor with a reasonable flow of referrals within the time limit set forth in the collective bargaining agreement, the contractor will, through independent recruitment efforts, fill the employment vacancies without regard to race, color, religion, sex, national origin, age or disability; making full efforts to obtain qualified and/or qualifiable minorities and women. The failure of a union to provide sufficient referrals (even though it is obligated to provide exclusive referrals under the terms of a collective bargaining agreement) does not relieve the contractor from the requirements of this paragraph. In the event the union referral practice prevents the contractor from meeting the obligations pursuant to Executive Order 11246, as amended, and these special provisions, such contractor shall immediately notify the contracting agency.

8. Reasonable Accommodation for Applicants / Employees with Disabilities: The contractor must be familiar

with the requirements for and comply with the Americans with Disabilities Act and all rules and regulations established there under. Employers must provide reasonable accommodation in all employment activities unless to do so would cause an undue hardship.

9. Selection of Subcontractors, Procurement of Materials and Leasing of Equipment: The contractor shall not discriminate on the grounds of race, color, religion, sex, national origin, age or disability in the selection and retention of subcontractors, including procurement of materials and leases of equipment. The contractor shall take all necessary and reasonable steps to ensure nondiscrimination in the administration of this contract.

a. The contractor shall notify all potential subcontractors and suppliers and lessors of their EEO obligations under this contract.

b. The contractor will use good faith efforts to ensure subcontractor compliance with their EEO obligations.

10. Assurance Required by 49 CFR 26.13(b):

a. The requirements of 49 CFR Part 26 and the State DOT's U.S. DOT-approved DBE program are incorporated by reference.

b. The contractor or subcontractor shall not discriminate on the basis of race, color, national origin, or sex in the performance of this contract. The contractor shall carry out applicable requirements of 49 CFR Part 26 in the award and administration of DOT-assisted contracts. Failure by the contractor to carry out these requirements is a material breach of this contract, which may result in the termination of this contract or such other remedy as the contracting agency deems appropriate.

11. Records and Reports: The contractor shall keep such records as necessary to document compliance with the EEO requirements. Such records shall be retained for a period of three years following the date of the final payment to the contractor for all contract work and shall be available at reasonable times and places for inspection by authorized representatives of the contracting agency and the FHWA.

a. The records kept by the contractor shall document the following:

(1) The number and work hours of minority and non-minority group members and women employed in each work classification on the project;

(2) The progress and efforts being made in cooperation with unions, when applicable, to increase employment opportunities for minorities and women; and

(3) The progress and efforts being made in locating, hiring, training, qualifying, and upgrading minorities and women;

b. The contractors and subcontractors will submit an annual report to the contracting agency each July for the duration of the project, indicating the number of minority, women, and non-minority group employees currently engaged in each work classification required by the contract work. This information is to be reported on [Form FHWA-1391](#). The staffing data should represent the project work force on board in all or any part of the last payroll period preceding the end of July. If on-the-job training is being required by special provision, the contractor

will be required to collect and report training data. The employment data should reflect the work force on board during all or any part of the last payroll period preceding the end of July.

III. NONSEGREGATED FACILITIES

This provision is applicable to all Federal-aid construction contracts and to all related construction subcontracts of \$10,000 or more.

The contractor must ensure that facilities provided for employees are provided in such a manner that segregation on the basis of race, color, religion, sex, or national origin cannot result. The contractor may neither require such segregated use by written or oral policies nor tolerate such use by employee custom. The contractor's obligation extends further to ensure that its employees are not assigned to perform their services at any location, under the contractor's control, where the facilities are segregated. The term "facilities" includes waiting rooms, work areas, restaurants and other eating areas, time clocks, restrooms, washrooms, locker rooms, and other storage or dressing areas, parking lots, drinking fountains, recreation or entertainment areas, transportation, and housing provided for employees. The contractor shall provide separate or single-user restrooms and necessary dressing or sleeping areas to assure privacy between sexes.

IV. DAVIS-BACON AND RELATED ACT PROVISIONS

This section is applicable to all Federal-aid construction projects exceeding \$2,000 and to all related subcontracts and lower-tier subcontracts (regardless of subcontract size). The requirements apply to all projects located within the right-of-way of a roadway that is functionally classified as Federal-aid highway. This excludes roadways functionally classified as local roads or rural minor collectors, which are exempt. Contracting agencies may elect to apply these requirements to other projects.

The following provisions are from the U.S. Department of Labor regulations in 29 CFR 5.5 "Contract provisions and related matters" with minor revisions to conform to the FHWA-1273 format and FHWA program requirements.

1. Minimum wages

a. All laborers and mechanics employed or working upon the site of the work, will be paid unconditionally and not less often than once a week, and without subsequent deduction or rebate on any account (except such payroll deductions as are permitted by regulations issued by the Secretary of Labor under the Copeland Act (29 CFR part 3)), the full amount of wages and bona fide fringe benefits (or cash equivalents thereof) due at time of payment computed at rates not less than those contained in the wage determination of the Secretary of Labor which is attached hereto and made a part hereof, regardless of any contractual relationship which may be alleged to exist between the contractor and such laborers and mechanics.

Contributions made or costs reasonably anticipated for bona fide fringe benefits under section 1(b)(2) of the Davis-Bacon Act on behalf of laborers or mechanics are considered wages paid to such laborers or mechanics, subject to the provisions

of paragraph 1.d. of this section; also, regular contributions made or costs incurred for more than a weekly period (but not less often than quarterly) under plans, funds, or programs which cover the particular weekly period, are deemed to be constructively made or incurred during such weekly period. Such laborers and mechanics shall be paid the appropriate wage rate and fringe benefits on the wage determination for the classification of work actually performed, without regard to skill, except as provided in 29 CFR 5.5(a)(4). Laborers or mechanics performing work in more than one classification may be compensated at the rate specified for each classification for the time actually worked therein: Provided, That the employer's payroll records accurately set forth the time spent in each classification in which work is performed. The wage determination (including any additional classification and wage rates conformed under paragraph 1.b. of this section) and the Davis-Bacon poster (WH-1321) shall be posted at all times by the contractor and its subcontractors at the site of the work in a prominent and accessible place where it can be easily seen by the workers.

b. (1) The contracting officer shall require that any class of laborers or mechanics, including helpers, which is not listed in the wage determination and which is to be employed under the contract shall be classified in conformance with the wage determination. The contracting officer shall approve an additional classification and wage rate and fringe benefits therefore only when the following criteria have been met:

(i) The work to be performed by the classification requested is not performed by a classification in the wage determination; and

(ii) The classification is utilized in the area by the construction industry; and

(iii) The proposed wage rate, including any bona fide fringe benefits, bears a reasonable relationship to the wage rates contained in the wage determination.

(2) If the contractor and the laborers and mechanics to be employed in the classification (if known), or their representatives, and the contracting officer agree on the classification and wage rate (including the amount designated for fringe benefits where appropriate), a report of the action taken shall be sent by the contracting officer to the Administrator of the Wage and Hour Division, Employment Standards Administration, U.S. Department of Labor, Washington, DC 20210. The Administrator, or an authorized representative, will approve, modify, or disapprove every additional classification action within 30 days of receipt and so advise the contracting officer or will notify the contracting officer within the 30-day period that additional time is necessary.

(3) In the event the contractor, the laborers or mechanics to be employed in the classification or their representatives, and the contracting officer do not agree on the proposed classification and wage rate (including the amount designated for fringe benefits, where appropriate), the contracting officer shall refer the questions, including the views of all interested parties and the recommendation of the contracting officer, to the Wage and Hour Administrator for determination. The Wage and Hour Administrator, or an authorized representative, will issue a determination within 30 days of receipt and so advise the contracting officer or

will notify the contracting officer within the 30-day period that additional time is necessary.

(4) The wage rate (including fringe benefits where appropriate) determined pursuant to paragraphs 1.b.(2) or 1.b.(3) of this section, shall be paid to all workers performing work in the classification under this contract from the first day on which work is performed in the classification.

c. Whenever the minimum wage rate prescribed in the contract for a class of laborers or mechanics includes a fringe benefit which is not expressed as an hourly rate, the contractor shall either pay the benefit as stated in the wage determination or shall pay another bona fide fringe benefit or an hourly cash equivalent thereof.

d. If the contractor does not make payments to a trustee or other third person, the contractor may consider as part of the wages of any laborer or mechanic the amount of any costs reasonably anticipated in providing bona fide fringe benefits under a plan or program. Provided, That the Secretary of Labor has found, upon the written request of the contractor, that the applicable standards of the Davis-Bacon Act have been met. The Secretary of Labor may require the contractor to set aside in a separate account assets for the meeting of obligations under the plan or program.

2. Withholding

The contracting agency shall upon its own action or upon written request of an authorized representative of the Department of Labor, withhold or cause to be withheld from the contractor under this contract, or any other Federal contract with the same prime contractor, or any other federally-assisted contract subject to Davis-Bacon prevailing wage requirements, which is held by the same prime contractor, so much of the accrued payments or advances as may be considered necessary to pay laborers and mechanics, including apprentices, trainees, and helpers, employed by the contractor or any subcontractor the full amount of wages required by the contract. In the event of failure to pay any laborer or mechanic, including any apprentice, trainee, or helper, employed or working on the site of the work, all or part of the wages required by the contract, the contracting agency may, after written notice to the contractor, take such action as may be necessary to cause the suspension of any further payment, advance, or guarantee of funds until such violations have ceased.

3. Payrolls and basic records

a. Payrolls and basic records relating thereto shall be maintained by the contractor during the course of the work and preserved for a period of three years thereafter for all laborers and mechanics working at the site of the work. Such records shall contain the name, address, and social security number of each such worker, his or her correct classification, hourly rates of wages paid (including rates of contributions or costs anticipated for bona fide fringe benefits or cash equivalents thereof of the types described in section 1(b)(2)(B) of the Davis-Bacon Act), daily and weekly number of hours worked, deductions made and actual wages paid. Whenever the Secretary of Labor has found under 29 CFR 5.5(a)(1)(iv) that the wages of any laborer or mechanic include the amount of any costs reasonably anticipated in providing benefits under a plan or program described in section 1(b)(2)(B) of the Davis-

Bacon Act, the contractor shall maintain records which show that the commitment to provide such benefits is enforceable, that the plan or program is financially responsible, and that the plan or program has been communicated in writing to the laborers or mechanics affected, and records which show the costs anticipated or the actual cost incurred in providing such benefits. Contractors employing apprentices or trainees under approved programs shall maintain written evidence of the registration of apprenticeship programs and certification of trainee programs, the registration of the apprentices and trainees, and the ratios and wage rates prescribed in the applicable programs.

b.(1) The contractor shall submit weekly for each week in which any contract work is performed a copy of all payrolls to the contracting agency. The payrolls submitted shall set out accurately and completely all of the information required to be maintained under 29 CFR 5.5(a)(3)(i), except that full social security numbers and home addresses shall not be included on weekly transmittals. Instead the payrolls shall only need to include an individually identifying number for each employee (e.g., the last four digits of the employee's social security number). The required weekly payroll information may be submitted in any form desired. Optional Form WH-347 is available for this purpose from the Wage and Hour Division Web site at <http://www.dol.gov/esa/whd/forms/wh347instr.htm> or its successor site. The prime contractor is responsible for the submission of copies of payrolls by all subcontractors. Contractors and subcontractors shall maintain the full social security number and current address of each covered worker, and shall provide them upon request to the contracting agency for transmission to the State DOT, the FHWA or the Wage and Hour Division of the Department of Labor for purposes of an investigation or audit of compliance with prevailing wage requirements. It is not a violation of this section for a prime contractor to require a subcontractor to provide addresses and social security numbers to the prime contractor for its own records, without weekly submission to the contracting agency..

(2) Each payroll submitted shall be accompanied by a "Statement of Compliance," signed by the contractor or subcontractor or his or her agent who pays or supervises the payment of the persons employed under the contract and shall certify the following:

(i) That the payroll for the payroll period contains the information required to be provided under §5.5 (a)(3)(ii) of Regulations, 29 CFR part 5, the appropriate information is being maintained under §5.5 (a)(3)(i) of Regulations, 29 CFR part 5, and that such information is correct and complete;

(ii) That each laborer or mechanic (including each helper, apprentice, and trainee) employed on the contract during the payroll period has been paid the full weekly wages earned, without rebate, either directly or indirectly, and that no deductions have been made either directly or indirectly from the full wages earned, other than permissible deductions as set forth in Regulations, 29 CFR part 3;

(iii) That each laborer or mechanic has been paid not less than the applicable wage rates and fringe benefits or cash equivalents for the classification of work performed, as specified in the applicable wage determination incorporated into the contract.

(3) The weekly submission of a properly executed certification set forth on the reverse side of Optional Form WH-347 shall satisfy the requirement for submission of the "Statement of Compliance" required by paragraph 3.b.(2) of this section.

(4) The falsification of any of the above certifications may subject the contractor or subcontractor to civil or criminal prosecution under section 1001 of title 18 and section 231 of title 31 of the United States Code.

c. The contractor or subcontractor shall make the records required under paragraph 3.a. of this section available for inspection, copying, or transcription by authorized representatives of the contracting agency, the State DOT, the FHWA, or the Department of Labor, and shall permit such representatives to interview employees during working hours on the job. If the contractor or subcontractor fails to submit the required records or to make them available, the FHWA may, after written notice to the contractor, the contracting agency or the State DOT, take such action as may be necessary to cause the suspension of any further payment, advance, or guarantee of funds. Furthermore, failure to submit the required records upon request or to make such records available may be grounds for debarment action pursuant to 29 CFR 5.12.

4. Apprentices and trainees

a. Apprentices (programs of the USDOL).

Apprentices will be permitted to work at less than the predetermined rate for the work they performed when they are employed pursuant to and individually registered in a bona fide apprenticeship program registered with the U.S. Department of Labor, Employment and Training Administration, Office of Apprenticeship Training, Employer and Labor Services, or with a State Apprenticeship Agency recognized by the Office, or if a person is employed in his or her first 90 days of probationary employment as an apprentice in such an apprenticeship program, who is not individually registered in the program, but who has been certified by the Office of Apprenticeship Training, Employer and Labor Services or a State Apprenticeship Agency (where appropriate) to be eligible for probationary employment as an apprentice.

The allowable ratio of apprentices to journeymen on the job site in any craft classification shall not be greater than the ratio permitted to the contractor as to the entire work force under the registered program. Any worker listed on a payroll at an apprentice wage rate, who is not registered or otherwise employed as stated above, shall be paid not less than the applicable wage rate on the wage determination for the classification of work actually performed. In addition, any apprentice performing work on the job site in excess of the ratio permitted under the registered program shall be paid not less than the applicable wage rate on the wage determination for the work actually performed. Where a contractor is performing construction on a project in a locality other than that in which its program is registered, the ratios and wage rates (expressed in percentages of the journeyman's hourly rate) specified in the contractor's or subcontractor's registered program shall be observed.

Every apprentice must be paid at not less than the rate specified in the registered program for the apprentice's level of progress, expressed as a percentage of the journeymen hourly

rate specified in the applicable wage determination. Apprentices shall be paid fringe benefits in accordance with the provisions of the apprenticeship program. If the apprenticeship program does not specify fringe benefits, apprentices must be paid the full amount of fringe benefits listed on the wage determination for the applicable classification. If the Administrator determines that a different practice prevails for the applicable apprentice classification, fringes shall be paid in accordance with that determination.

In the event the Office of Apprenticeship Training, Employer and Labor Services, or a State Apprenticeship Agency recognized by the Office, withdraws approval of an apprenticeship program, the contractor will no longer be permitted to utilize apprentices at less than the applicable predetermined rate for the work performed until an acceptable program is approved.

b. Trainees (programs of the USDOL).

Except as provided in 29 CFR 5.16, trainees will not be permitted to work at less than the predetermined rate for the work performed unless they are employed pursuant to and individually registered in a program which has received prior approval, evidenced by formal certification by the U.S. Department of Labor, Employment and Training Administration.

The ratio of trainees to journeymen on the job site shall not be greater than permitted under the plan approved by the Employment and Training Administration.

Every trainee must be paid at not less than the rate specified in the approved program for the trainee's level of progress, expressed as a percentage of the journeyman hourly rate specified in the applicable wage determination. Trainees shall be paid fringe benefits in accordance with the provisions of the trainee program. If the trainee program does not mention fringe benefits, trainees shall be paid the full amount of fringe benefits listed on the wage determination unless the Administrator of the Wage and Hour Division determines that there is an apprenticeship program associated with the corresponding journeyman wage rate on the wage determination which provides for less than full fringe benefits for apprentices. Any employee listed on the payroll at a trainee rate who is not registered and participating in a training plan approved by the Employment and Training Administration shall be paid not less than the applicable wage rate on the wage determination for the classification of work actually performed. In addition, any trainee performing work on the job site in excess of the ratio permitted under the registered program shall be paid not less than the applicable wage rate on the wage determination for the work actually performed.

In the event the Employment and Training Administration withdraws approval of a training program, the contractor will no longer be permitted to utilize trainees at less than the applicable predetermined rate for the work performed until an acceptable program is approved.

c. Equal employment opportunity. The utilization of apprentices, trainees and journeymen under this part shall be in conformity with the equal employment opportunity requirements of Executive Order 11246, as amended, and 29 CFR part 30.

d. Apprentices and Trainees (programs of the U.S. DOT).

Apprentices and trainees working under apprenticeship and skill training programs which have been certified by the Secretary of Transportation as promoting EEO in connection with Federal-aid highway construction programs are not subject to the requirements of paragraph 4 of this Section IV. The straight time hourly wage rates for apprentices and trainees under such programs will be established by the particular programs. The ratio of apprentices and trainees to journeymen shall not be greater than permitted by the terms of the particular program.

5. Compliance with Copeland Act requirements. The contractor shall comply with the requirements of 29 CFR part 3, which are incorporated by reference in this contract.

6. Subcontracts. The contractor or subcontractor shall insert Form FHWA-1273 in any subcontracts and also require the subcontractors to include Form FHWA-1273 in any lower tier subcontracts. The prime contractor shall be responsible for the compliance by any subcontractor or lower tier subcontractor with all the contract clauses in 29 CFR 5.5.

7. Contract termination: debarment. A breach of the contract clauses in 29 CFR 5.5 may be grounds for termination of the contract, and for debarment as a contractor and a subcontractor as provided in 29 CFR 5.12.

8. Compliance with Davis-Bacon and Related Act requirements. All rulings and interpretations of the Davis-Bacon and Related Acts contained in 29 CFR parts 1, 3, and 5 are herein incorporated by reference in this contract.

9. Disputes concerning labor standards. Disputes arising out of the labor standards provisions of this contract shall not be subject to the general disputes clause of this contract. Such disputes shall be resolved in accordance with the procedures of the Department of Labor set forth in 29 CFR parts 5, 6, and 7. Disputes within the meaning of this clause include disputes between the contractor (or any of its subcontractors) and the contracting agency, the U.S. Department of Labor, or the employees or their representatives.

10. Certification of eligibility.

a. By entering into this contract, the contractor certifies that neither it (nor he or she) nor any person or firm who has an interest in the contractor's firm is a person or firm ineligible to be awarded Government contracts by virtue of section 3(a) of the Davis-Bacon Act or 29 CFR 5.12(a)(1).

b. No part of this contract shall be subcontracted to any person or firm ineligible for award of a Government contract by virtue of section 3(a) of the Davis-Bacon Act or 29 CFR 5.12(a)(1).

c. The penalty for making false statements is prescribed in the U.S. Criminal Code, 18 U.S.C. 1001.

V. CONTRACT WORK HOURS AND SAFETY STANDARDS ACT

The following clauses apply to any Federal-aid construction contract in an amount in excess of \$100,000 and subject to the overtime provisions of the Contract Work Hours and Safety Standards Act. These clauses shall be inserted in addition to the clauses required by 29 CFR 5.5(a) or 29 CFR 4.6. As used in this paragraph, the terms laborers and mechanics include watchmen and guards.

1. Overtime requirements. No contractor or subcontractor contracting for any part of the contract work which may require or involve the employment of laborers or mechanics shall require or permit any such laborer or mechanic in any workweek in which he or she is employed on such work to work in excess of forty hours in such workweek unless such laborer or mechanic receives compensation at a rate not less than one and one-half times the basic rate of pay for all hours worked in excess of forty hours in such workweek.

2. Violation; liability for unpaid wages; liquidated damages. In the event of any violation of the clause set forth in paragraph (1.) of this section, the contractor and any subcontractor responsible therefor shall be liable for the unpaid wages. In addition, such contractor and subcontractor shall be liable to the United States (in the case of work done under contract for the District of Columbia or a territory, to such District or to such territory), for liquidated damages. Such liquidated damages shall be computed with respect to each individual laborer or mechanic, including watchmen and guards, employed in violation of the clause set forth in paragraph (1.) of this section, in the sum of \$10 for each calendar day on which such individual was required or permitted to work in excess of the standard workweek of forty hours without payment of the overtime wages required by the clause set forth in paragraph (1.) of this section.

3. Withholding for unpaid wages and liquidated damages. The FHWA or the contracting agency shall upon its own action or upon written request of an authorized representative of the Department of Labor withhold or cause to be withheld, from any moneys payable on account of work performed by the contractor or subcontractor under any such contract or any other Federal contract with the same prime contractor, or any other federally-assisted contract subject to the Contract Work Hours and Safety Standards Act, which is held by the same prime contractor, such sums as may be determined to be necessary to satisfy any liabilities of such contractor or subcontractor for unpaid wages and liquidated damages as provided in the clause set forth in paragraph (2.) of this section.

4. Subcontracts. The contractor or subcontractor shall insert in any subcontracts the clauses set forth in paragraph (1.) through (4.) of this section and also a clause requiring the subcontractors to include these clauses in any lower tier subcontracts. The prime contractor shall be responsible for compliance by any subcontractor or lower tier subcontractor with the clauses set forth in paragraphs (1.) through (4.) of this section.

VI. SUBLETTING OR ASSIGNING THE CONTRACT

This provision is applicable to all Federal-aid construction contracts on the National Highway System.

1. The contractor shall perform with its own organization contract work amounting to not less than 30 percent (or a greater percentage if specified elsewhere in the contract) of the total original contract price, excluding any specialty items designated by the contracting agency. Specialty items may be performed by subcontract and the amount of any such specialty items performed may be deducted from the total original contract price before computing the amount of work required to be performed by the contractor's own organization (23 CFR 635.116).

a. The term "perform work with its own organization" refers to workers employed or leased by the prime contractor, and equipment owned or rented by the prime contractor, with or without operators. Such term does not include employees or equipment of a subcontractor or lower tier subcontractor, agents of the prime contractor, or any other assignees. The term may include payments for the costs of hiring leased employees from an employee leasing firm meeting all relevant Federal and State regulatory requirements. Leased employees may only be included in this term if the prime contractor meets all of the following conditions:

(1) the prime contractor maintains control over the supervision of the day-to-day activities of the leased employees;

(2) the prime contractor remains responsible for the quality of the work of the leased employees;

(3) the prime contractor retains all power to accept or exclude individual employees from work on the project; and

(4) the prime contractor remains ultimately responsible for the payment of predetermined minimum wages, the submission of payrolls, statements of compliance and all other Federal regulatory requirements.

b. "Specialty Items" shall be construed to be limited to work that requires highly specialized knowledge, abilities, or equipment not ordinarily available in the type of contracting organizations qualified and expected to bid or propose on the contract as a whole and in general are to be limited to minor components of the overall contract.

2. The contract amount upon which the requirements set forth in paragraph (1) of Section VI is computed includes the cost of material and manufactured products which are to be purchased or produced by the contractor under the contract provisions.

3. The contractor shall furnish (a) a competent superintendent or supervisor who is employed by the firm, has full authority to direct performance of the work in accordance with the contract requirements, and is in charge of all construction operations (regardless of who performs the work) and (b) such other of its own organizational resources (supervision, management, and engineering services) as the contracting officer determines is necessary to assure the performance of the contract.

4. No portion of the contract shall be sublet, assigned or otherwise disposed of except with the written consent of the contracting officer, or authorized representative, and such consent when given shall not be construed to relieve the contractor of any responsibility for the fulfillment of the contract. Written consent will be given only after the contracting agency has assured that each subcontract is

evidenced in writing and that it contains all pertinent provisions and requirements of the prime contract.

5. The 30% self-performance requirement of paragraph (1) is not applicable to design-build contracts; however, contracting agencies may establish their own self-performance requirements.

VII. SAFETY: ACCIDENT PREVENTION

This provision is applicable to all Federal-aid construction contracts and to all related subcontracts.

1. In the performance of this contract the contractor shall comply with all applicable Federal, State, and local laws governing safety, health, and sanitation (23 CFR 635). The contractor shall provide all safeguards, safety devices and protective equipment and take any other needed actions as it determines, or as the contracting officer may determine, to be reasonably necessary to protect the life and health of employees on the job and the safety of the public and to protect property in connection with the performance of the work covered by the contract.

2. It is a condition of this contract, and shall be made a condition of each subcontract, which the contractor enters into pursuant to this contract, that the contractor and any subcontractor shall not permit any employee, in performance of the contract, to work in surroundings or under conditions which are unsanitary, hazardous or dangerous to his/her health or safety, as determined under construction safety and health standards (29 CFR 1926) promulgated by the Secretary of Labor, in accordance with Section 107 of the Contract Work Hours and Safety Standards Act (40 U.S.C. 3704).

3. Pursuant to 29 CFR 1926.3, it is a condition of this contract that the Secretary of Labor or authorized representative thereof, shall have right of entry to any site of contract performance to inspect or investigate the matter of compliance with the construction safety and health standards and to carry out the duties of the Secretary under Section 107 of the Contract Work Hours and Safety Standards Act (40 U.S.C.3704).

VIII. FALSE STATEMENTS CONCERNING HIGHWAY PROJECTS

This provision is applicable to all Federal-aid construction contracts and to all related subcontracts.

In order to assure high quality and durable construction in conformity with approved plans and specifications and a high degree of reliability on statements and representations made by engineers, contractors, suppliers, and workers on Federal-aid highway projects, it is essential that all persons concerned with the project perform their functions as carefully, thoroughly, and honestly as possible. Willful falsification, distortion, or misrepresentation with respect to any facts related to the project is a violation of Federal law. To prevent any misunderstanding regarding the seriousness of these and similar acts, Form FHWA-1022 shall be posted on each Federal-aid highway project (23 CFR 635) in one or more places where it is readily available to all persons concerned with the project:

18 U.S.C. 1020 reads as follows:

"Whoever, being an officer, agent, or employee of the United States, or of any State or Territory, or whoever, whether a person, association, firm, or corporation, knowingly makes any false statement, false representation, or false report as to the character, quality, quantity, or cost of the material used or to be used, or the quantity or quality of the work performed or to be performed, or the cost thereof in connection with the submission of plans, maps, specifications, contracts, or costs of construction on any highway or related project submitted for approval to the Secretary of Transportation; or

Whoever knowingly makes any false statement, false representation, false report or false claim with respect to the character, quality, quantity, or cost of any work performed or to be performed, or materials furnished or to be furnished, in connection with the construction of any highway or related project approved by the Secretary of Transportation; or

Whoever knowingly makes any false statement or false representation as to material fact in any statement, certificate, or report submitted pursuant to provisions of the Federal-aid Roads Act approved July 1, 1916, (39 Stat. 355), as amended and supplemented;

Shall be fined under this title or imprisoned not more than 5 years or both."

IX. IMPLEMENTATION OF CLEAN AIR ACT AND FEDERAL WATER POLLUTION CONTROL ACT

This provision is applicable to all Federal-aid construction contracts and to all related subcontracts.

By submission of this bid/proposal or the execution of this contract, or subcontract, as appropriate, the bidder, proposer, Federal-aid construction contractor, or subcontractor, as appropriate, will be deemed to have stipulated as follows:

1. That any person who is or will be utilized in the performance of this contract is not prohibited from receiving an award due to a violation of Section 508 of the Clean Water Act or Section 306 of the Clean Air Act.

2. That the contractor agrees to include or cause to be included the requirements of paragraph (1) of this Section X in every subcontract, and further agrees to take such action as the contracting agency may direct as a means of enforcing such requirements.

X. CERTIFICATION REGARDING DEBARMENT, SUSPENSION, INELIGIBILITY AND VOLUNTARY EXCLUSION

This provision is applicable to all Federal-aid construction contracts, design-build contracts, subcontracts, lower-tier subcontracts, purchase orders, lease agreements, consultant contracts or any other covered transaction requiring FHWA approval or that is estimated to cost \$25,000 or more – as defined in 2 CFR Parts 180 and 1200.

1. Instructions for Certification – First Tier Participants:

a. By signing and submitting this proposal, the prospective first tier participant is providing the certification set out below.

b. The inability of a person to provide the certification set out below will not necessarily result in denial of participation in this

covered transaction. The prospective first tier participant shall submit an explanation of why it cannot provide the certification set out below. The certification or explanation will be considered in connection with the department or agency's determination whether to enter into this transaction. However, failure of the prospective first tier participant to furnish a certification or an explanation shall disqualify such a person from participation in this transaction.

c. The certification in this clause is a material representation of fact upon which reliance was placed when the contracting agency determined to enter into this transaction. If it is later determined that the prospective participant knowingly rendered an erroneous certification, in addition to other remedies available to the Federal Government, the contracting agency may terminate this transaction for cause of default.

d. The prospective first tier participant shall provide immediate written notice to the contracting agency to whom this proposal is submitted if any time the prospective first tier participant learns that its certification was erroneous when submitted or has become erroneous by reason of changed circumstances.

e. The terms "covered transaction," "debarred," "suspended," "ineligible," "participant," "person," "principal," and "voluntarily excluded," as used in this clause, are defined in 2 CFR Parts 180 and 1200. "First Tier Covered Transactions" refers to any covered transaction between a grantee or subgrantee of Federal funds and a participant (such as the prime or general contract). "Lower Tier Covered Transactions" refers to any covered transaction under a First Tier Covered Transaction (such as subcontracts). "First Tier Participant" refers to the participant who has entered into a covered transaction with a grantee or subgrantee of Federal funds (such as the prime or general contractor). "Lower Tier Participant" refers any participant who has entered into a covered transaction with a First Tier Participant or other Lower Tier Participants (such as subcontractors and suppliers).

f. The prospective first tier participant agrees by submitting this proposal that, should the proposed covered transaction be entered into, it shall not knowingly enter into any lower tier covered transaction with a person who is debarred, suspended, declared ineligible, or voluntarily excluded from participation in this covered transaction, unless authorized by the department or agency entering into this transaction.

g. The prospective first tier participant further agrees by submitting this proposal that it will include the clause titled "Certification Regarding Debarment, Suspension, Ineligibility and Voluntary Exclusion-Lower Tier Covered Transactions," provided by the department or contracting agency, entering into this covered transaction, without modification, in all lower tier covered transactions and in all solicitations for lower tier covered transactions exceeding the \$25,000 threshold.

h. A participant in a covered transaction may rely upon a certification of a prospective participant in a lower tier covered transaction that is not debarred, suspended, ineligible, or voluntarily excluded from the covered transaction, unless it knows that the certification is erroneous. A participant is responsible for ensuring that its principals are not suspended, debarred, or otherwise ineligible to participate in covered transactions. To verify the eligibility of its principals, as well as the eligibility of any lower tier prospective participants, each participant may, but is not required to, check the Excluded Parties List System website (<https://www.epls.gov/>), which is compiled by the General Services Administration.

i. Nothing contained in the foregoing shall be construed to require the establishment of a system of records in order to render in good faith the certification required by this clause. The knowledge and information of the prospective participant is not required to exceed that which is normally possessed by a prudent person in the ordinary course of business dealings.

j. Except for transactions authorized under paragraph (f) of these instructions, if a participant in a covered transaction knowingly enters into a lower tier covered transaction with a person who is suspended, debarred, ineligible, or voluntarily excluded from participation in this transaction, in addition to other remedies available to the Federal Government, the department or agency may terminate this transaction for cause or default.

* * * * *

2. Certification Regarding Debarment, Suspension, Ineligibility and Voluntary Exclusion – First Tier Participants:

a. The prospective first tier participant certifies to the best of its knowledge and belief, that it and its principals:

(1) Are not presently debarred, suspended, proposed for debarment, declared ineligible, or voluntarily excluded from participating in covered transactions by any Federal department or agency;

(2) Have not within a three-year period preceding this proposal been convicted of or had a civil judgment rendered against them for commission of fraud or a criminal offense in connection with obtaining, attempting to obtain, or performing a public (Federal, State or local) transaction or contract under a public transaction; violation of Federal or State antitrust statutes or commission of embezzlement, theft, forgery, bribery, falsification or destruction of records, making false statements, or receiving stolen property;

(3) Are not presently indicted for or otherwise criminally or civilly charged by a governmental entity (Federal, State or local) with commission of any of the offenses enumerated in paragraph (a)(2) of this certification; and

(4) Have not within a three-year period preceding this application/proposal had one or more public transactions (Federal, State or local) terminated for cause or default.

b. Where the prospective participant is unable to certify to any of the statements in this certification, such prospective participant shall attach an explanation to this proposal.

2. Instructions for Certification - Lower Tier Participants:

(Applicable to all subcontracts, purchase orders and other lower tier transactions requiring prior FHWA approval or estimated to cost \$25,000 or more - 2 CFR Parts 180 and 1200)

a. By signing and submitting this proposal, the prospective lower tier is providing the certification set out below.

b. The certification in this clause is a material representation of fact upon which reliance was placed when this transaction was entered into. If it is later determined that the prospective lower tier participant knowingly rendered an erroneous certification, in addition to other remedies available to the Federal Government, the department, or agency with which

this transaction originated may pursue available remedies, including suspension and/or debarment.

c. The prospective lower tier participant shall provide immediate written notice to the person to which this proposal is submitted if at any time the prospective lower tier participant learns that its certification was erroneous by reason of changed circumstances.

d. The terms "covered transaction," "debarred," "suspended," "ineligible," "participant," "person," "principal," and "voluntarily excluded," as used in this clause, are defined in 2 CFR Parts 180 and 1200. You may contact the person to which this proposal is submitted for assistance in obtaining a copy of those regulations. "First Tier Covered Transactions" refers to any covered transaction between a grantee or subgrantee of Federal funds and a participant (such as the prime or general contract). "Lower Tier Covered Transactions" refers to any covered transaction under a First Tier Covered Transaction (such as subcontracts). "First Tier Participant" refers to the participant who has entered into a covered transaction with a grantee or subgrantee of Federal funds (such as the prime or general contractor). "Lower Tier Participant" refers any participant who has entered into a covered transaction with a First Tier Participant or other Lower Tier Participants (such as subcontractors and suppliers).

e. The prospective lower tier participant agrees by submitting this proposal that, should the proposed covered transaction be entered into, it shall not knowingly enter into any lower tier covered transaction with a person who is debarred, suspended, declared ineligible, or voluntarily excluded from participation in this covered transaction, unless authorized by the department or agency with which this transaction originated.

f. The prospective lower tier participant further agrees by submitting this proposal that it will include this clause titled "Certification Regarding Debarment, Suspension, Ineligibility and Voluntary Exclusion-Lower Tier Covered Transaction," without modification, in all lower tier covered transactions and in all solicitations for lower tier covered transactions exceeding the \$25,000 threshold.

g. A participant in a covered transaction may rely upon a certification of a prospective participant in a lower tier covered transaction that is not debarred, suspended, ineligible, or voluntarily excluded from the covered transaction, unless it knows that the certification is erroneous. A participant is responsible for ensuring that its principals are not suspended, debarred, or otherwise ineligible to participate in covered transactions. To verify the eligibility of its principals, as well as the eligibility of any lower tier prospective participants, each participant may, but is not required to, check the Excluded Parties List System website (<https://www.epls.gov/>), which is compiled by the General Services Administration.

h. Nothing contained in the foregoing shall be construed to require establishment of a system of records in order to render in good faith the certification required by this clause. The knowledge and information of participant is not required to exceed that which is normally possessed by a prudent person in the ordinary course of business dealings.

i. Except for transactions authorized under paragraph e of these instructions, if a participant in a covered transaction knowingly enters into a lower tier covered transaction with a person who is suspended, debarred, ineligible, or voluntarily excluded from participation in this transaction, in addition to other remedies available to the Federal Government, the

department or agency with which this transaction originated may pursue available remedies, including suspension and/or debarment.

* * * * *

Certification Regarding Debarment, Suspension, Ineligibility and Voluntary Exclusion--Lower Tier Participants:

1. The prospective lower tier participant certifies, by submission of this proposal, that neither it nor its principals is presently debarred, suspended, proposed for debarment, declared ineligible, or voluntarily excluded from participating in covered transactions by any Federal department or agency.

2. Where the prospective lower tier participant is unable to certify to any of the statements in this certification, such prospective participant shall attach an explanation to this proposal.

* * * * *

XI. CERTIFICATION REGARDING USE OF CONTRACT FUNDS FOR LOBBYING

This provision is applicable to all Federal-aid construction contracts and to all related subcontracts which exceed \$100,000 (49 CFR 20).

1. The prospective participant certifies, by signing and submitting this bid or proposal, to the best of his or her knowledge and belief, that:

a. No Federal appropriated funds have been paid or will be paid, by or on behalf of the undersigned, to any person for influencing or attempting to influence an officer or employee of any Federal agency, a Member of Congress, an officer or employee of Congress, or an employee of a Member of Congress in connection with the awarding of any Federal contract, the making of any Federal grant, the making of any Federal loan, the entering into of any cooperative agreement, and the extension, continuation, renewal, amendment, or modification of any Federal contract, grant, loan, or cooperative agreement.

b. If any funds other than Federal appropriated funds have been paid or will be paid to any person for influencing or attempting to influence an officer or employee of any Federal agency, a Member of Congress, an officer or employee of Congress, or an employee of a Member of Congress in connection with this Federal contract, grant, loan, or cooperative agreement, the undersigned shall complete and submit Standard Form-LLL, "Disclosure Form to Report Lobbying," in accordance with its instructions.

2. This certification is a material representation of fact upon which reliance was placed when this transaction was made or entered into. Submission of this certification is a prerequisite for making or entering into this transaction imposed by 31 U.S.C. 1352. Any person who fails to file the required certification shall be subject to a civil penalty of not less than \$10,000 and not more than \$100,000 for each such failure.

3. The prospective participant also agrees by submitting its bid or proposal that the participant shall require that the language of this certification be included in all lower tier subcontracts, which exceed \$100,000 and that all such recipients shall certify and disclose accordingly.

**ATTACHMENT A - EMPLOYMENT AND MATERIALS
PREFERENCE FOR APPALACHIAN DEVELOPMENT
HIGHWAY SYSTEM OR APPALACHIAN LOCAL ACCESS
ROAD CONTRACTS**

This provision is applicable to all Federal-aid projects funded under the Appalachian Regional Development Act of 1965.

1. During the performance of this contract, the contractor undertaking to do work which is, or reasonably may be, done as on-site work, shall give preference to qualified persons who regularly reside in the labor area as designated by the DOL wherein the contract work is situated, or the subregion, or the Appalachian counties of the State wherein the contract work is situated, except:

a. To the extent that qualified persons regularly residing in the area are not available.

b. For the reasonable needs of the contractor to employ supervisory or specially experienced personnel necessary to assure an efficient execution of the contract work.

c. For the obligation of the contractor to offer employment to present or former employees as the result of a lawful collective bargaining contract, provided that the number of nonresident persons employed under this subparagraph (1c) shall not exceed 20 percent of the total number of employees employed by the contractor on the contract work, except as provided in subparagraph (4) below.

2. The contractor shall place a job order with the State Employment Service indicating (a) the classifications of the laborers, mechanics and other employees required to perform the contract work, (b) the number of employees required in each classification, (c) the date on which the participant estimates such employees will be required, and (d) any other pertinent information required by the State Employment Service to complete the job order form. The job order may be placed with the State Employment Service in writing or by telephone. If during the course of the contract work, the information submitted by the contractor in the original job order is substantially modified, the participant shall promptly notify the State Employment Service.

3. The contractor shall give full consideration to all qualified job applicants referred to him by the State Employment Service. The contractor is not required to grant employment to any job applicants who, in his opinion, are not qualified to perform the classification of work required.

4. If, within one week following the placing of a job order by the contractor with the State Employment Service, the State Employment Service is unable to refer any qualified job applicants to the contractor, or less than the number requested, the State Employment Service will forward a certificate to the contractor indicating the unavailability of applicants. Such certificate shall be made a part of the contractor's permanent project records. Upon receipt of this certificate, the contractor may employ persons who do not normally reside in the labor area to fill positions covered by the certificate, notwithstanding the provisions of subparagraph (1c) above.

5. The provisions of 23 CFR 633.207(e) allow the contracting agency to provide a contractual preference for the use of mineral resource materials native to the Appalachian region.

6. The contractor shall include the provisions of Sections 1 through 4 of this Attachment A in every subcontract for work which is, or reasonably may be, done as on-site work.

Essex County Supplementary Terms and Conditions to Agreement

1. No application for payment shall be deemed complete or approved by Essex County, and no progress payment shall be due from Essex County, unless Contractor shall have submitted properly executed Public Improvement Lien Releases and Waivers, in a form satisfactory to Essex County, signed by all persons who could claim public improvement lien rights on the project in connection with the work, and acknowledging payment of all work, materials and equipment supplied to the project up to and including the last day covered by the application for payment. Lien releases and Waivers from each individual subcontractor and material supplier must be presented prior to the progress payment being made. Essex County reserves the right to request further substantiation from Contractor of such payments, including substantiation that all required payments have been made to fringe benefit trust funds for the benefit of employees of Contractor or subcontractors who have provided services to the project in connection with the work, however, Essex County's failure to require such shall not be deemed a waiver or diminution of Essex County's rights.

2. The application for final payment shall not be deemed completed or approved by Essex County, and no payment shall be due from Essex County until Contractor shall have submitted the following properly executed documents:
 - (1) A General Release from Contractor in favor of Essex County;
 - (2) A Final Release and Waiver of any public improvement lien rights of Contractor;
 - (3) A sworn statement by Contractor, and a form satisfactory to Essex County, indicating that all subcontractors, materials suppliers, and fringe benefit trust funds for employees of Contractor and subcontractors on the project encompassed by the work, as well as all workers and persons employed in connection herewith, have been paid in full for all labor and work and materials furnished;
 - (4) An Indemnity Agreement whereby Contractor shall defend and indemnify Essex County from any and all claims of every and any kind in nature by third parties, including but not limited to materials suppliers, subcontractors, and employees and workers employed in this project; and
 - (5) Final Lien Releases and Waivers from each individual materials supplier and subcontractor.

3. Neither final payment or any remaining retained percentage shall become due until Contractor submits to Essex County:
 - (1) Affidavit that payrolls, bills for materials and equipment, and other indebtedness connected with the work for which Essex County or Essex County's property might be responsible or encumbered (less amounts held by Essex County) have been paid or otherwise satisfied;
 - (2) A certificate evidencing that insurance required by the contract is to remain in full force after final payment is currently in effect and will not be

- canceled or allowed to expire until at least thirty (30) days prior written notice has been given to Essex County;
- (3) A written statement that Contractor knows of no substantial reason that the insurance will not be renewed to cover the period required by the contract;
 - (4) Consent of surety, if any, to final payment; and
 - (5) If required by Essex County, other data establishing payment or satisfaction of obligations such as receipts, releases and waivers of liens, claims, security interests or encumbrance arising out of the contract, to the extent and in such form as may be designated by Essex County.

4. CLAIMS AND DISPUTES

4.1 Definition. A Claim is a demand or assertion by one of the parties seeking, as a matter of right, adjustment or interpretation of Contract terms, payment of money, extension of time or other relief with respect to the terms of the contract. The term "Claim" also includes other disputes and matters in question between Essex County and Contractor arising out of or relating to the Contract. Claims must be made by written notice. The responsibility to substantiate Claims shall rest with the party making the Claim. The written notice of claim must be accompanied by full documentation and proof to substantiate the claim.

4.2 Decision of Essex County, its Engineer or Construction Manager. Claims shall be referred initially to Essex County, or its Engineer or Construction Manager for action as provided below. A decision by Essex County or its Engineer or Construction Manager, shall be required as a condition precedent to litigation of a Claim between Essex County and Contractor as to all such matters arising prior to the date final payment is due, regardless of (1) whether such matters relate to the execution and progress of the Work or (2) the extend to which the Work has been completed. The decision by Essex County or Construction Manager in response to a Claim shall not be a condition precedent to arbitration or litigation in the event (1) the position of Essex County or Construction Manager is vacant, (2) Essex County or Construction Manager has not received evidence or has failed to render a decision within agreed time limits, (3) Essex County or its Engineer or Construction Manager has failed to take action required under Section 4.3 within fifteen (15) days after the Claim is made, (4) forty-five (45) days has passed after the Claim has been referred to Essex County or its Engineer or Construction Manager or (5) the Claim relates to a mechanic's lien.

4.3 Time Limits on Claims. Claims by either party must be made within fifteen (15) days after occurrence of the even giving rise to such Claim or within fifteen (15) days after the claimant first recognizes the condition giving rise to the Claim, whichever is later. Claims must be made by written notice. An additional Claim made after the initial Claim has been implemented by Change Order will not be considered unless submitted in a timely manner.

4.4 Continuing Contract Performance. Pending final resolution of a Claim, unless otherwise agreed in writing Contractor shall proceed diligently with performance of the Contract and Essex County shall continue to make payments in accordance with the Contract Documents.

4.5 Waiver of Claims: Final Payment. The making of final payment shall constitute a waiver of Claims by Essex County except those arising from:

1. Liens, Claims, security interests or encumbrances arising out of the Contract and unsettled;
2. Failure of the Work to comply with the requirements of the Contract Documents; or
3. Terms of special warranties required by the Contract Documents.

4.6 Claims for Concealed or Unknown Conditions. If condition are encountered at the site which are (1) subsurface or otherwise concealed physical conditions which differ materially from those indicated in the Contract Documents or (2) unknown physical conditions of an unusual nature, which differ materially from those ordinarily found to exist and generally recognized as inherent in construction activities of the character provided for in the Contract documents, then notice by the observing party shall be given to the other party promptly before conditions are disturbed and in no event later than 15 days after first observance of the conditions. Essex County or its Engineer or Construction Manager will promptly investigate such conditions and, if they differ materially and cause an increase or decrease in Contractor's cost of, or time required for, performance of any part of the Work, will recommend an equitable adjustment in the Contract Sum or Contract Time, or both. If Essex County or its Engineer or Construction Manager determines that the conditions at the site are not materially different from those indicated in the Contract Documents and that no change in the terms of the Contract is justified, Essex County shall so notify Essex County and Contractor in writing, stating the reasons. Claims by either party in opposition to such determination must be made within fifteen (15) days after Essex County has given notice of the decision. If Essex County and Contractor cannot agree on an adjustment in the Contract Sum or Contract Time, the adjustment shall be referred to Essex County or its Engineer or Construction Manager for initial determination.

4.7 Claim for Additional Cost. If Contractor wishes to make Claim for an increase in the Contract Sum, written notice as provided herein shall be given before proceeding to execute the Work. If Contractor believes additional cost is involved for reasons including but not limited to (1) a written interpretation from Essex County or its Engineer or Construction Manager, (2) an order by Essex County to stop the Work where Contractor was not at fault, (3) a written order for a minor change in the Work issued by Essex County or its Engineer or Construction Manager, (4) failure of payment by Essex County, (5) termination of the contract by Essex County, (6) Essex County's suspension or (7) other reasonable grounds, Claim shall be filed and evaluated in accordance with

the procedure established herein and under this Section (4) and Section (5) of these Supplementary Conditions.

5. RESOLUTION OF CLAIMS AND DISPUTES

5.1 Essex County or Construction Manager will review Claims and take one or more of the following preliminary actions within fifteen (15) days of receipt of a Claim: (1) request additional supporting data from the claimant, (2) submit a schedule to the parties indicating when Essex County or Construction Manager expects to take action, (3) reject the Claim in whole or in part, stating reasons for rejection, (4) recommend approval of the Claim by the other party or (5) suggest a compromise. Essex County or Construction Manager may also, but is not obligated to, notify the surety, if any, of the nature and amount of the Claim.

5.2 If a Claim has been resolved, Essex County or Construction Manager will prepare or obtain appropriate documentation.

5.3 If a Claim has not been resolved, the party making the Claim shall, within ten days after Essex County or Construction Manager's preliminary response, take one or more of the following actions: (1) submit additional supporting data requested by Essex County or Construction Manager, (2) modify the initial Claim or (3) notify Essex County or Construction Manager that the initial Claim stands.

5.4 If a Claim has not been resolved after consideration of the foregoing and of further evidence presented by the parties or requested by Essex County or Construction Manager, Essex County or Construction Manager will notify the parties in writing that Essex County or Construction Manager's decision will be made within ten (10) days, which decision shall be final and binding on the parties but subject to arbitration. Upon expiration of such time period, Essex County or Construction Manager will render to the parties Essex County or Construction Manager's written decision relative to the Claim, including any change in the Contract Sum or Contract Time or both. If there is a surety and there appears to be a possibility of a Contractor's default, Essex County or Construction Manager may, but is not obligated to, notify the surety and request the surety's assistance in resolving the controversy.

The parties expressly agree that any and all controversies and claims arising out of this contract will not be referred to arbitration but will be referred and brought in a Court of competent jurisdiction within Essex County, New York.

6. DELAYS. Essex County shall not be liable to Contractor or any subcontractors

for claims or damages of any nature caused by or rising out of delays. The sole remedy against Essex County for delays shall be the allowance of additional time for completion of the Work, the amount of which shall be subject to the claims procedure set forth herein. Except to the extent, if any, expressly prohibited by law, Contractor expressly agrees not to make and hereby waives any claim for damages for delay, including, but not limited to those resulting from increased labor or material costs, directions given or

not given by Essex County, including scheduling of the work, or an account of any delay, or on account of any delay, obstruction or hindrance for any cause whatsoever by Essex County, or its agents or any other Contractor on the project, whether or not foreseeable or anticipated. CONTRACTOR AGREES THAT ITS SOLE RIGHT AND REMEDY THEREFORE SHALL BE AN EXTENSION OF TIME, IF APPROPRIATE. IT IS EMPHASIZED THAT NO MONETARY RECOVERY MAY BE OBTAINED BY CONTRACTOR FOR ANY DELAY AGAINST ESSEX COUNTY, CONSTRUCTION MANAGER, OR ITS ENGINEER OR CONSTRUCTION MANAGER BASED ON ANY REASON AND THAT CONTRACTOR'S SOLE REMEDY, IF APPROPRIATE, IS ADDITIONAL TIME.

7. Subcontractors and their subcontractors are required to defend, indemnify and hold harmless, to the full extent allowed by law, Essex County, any Essex County or Construction Manager from and against any and all claims, suits, causes of actions, judgments, etc. arising out of or in any way connected with the subcontractors performance of the work as well as name Essex County, Architect and Construction Manager, if any, as an additional insured on its policies of liability insurance. Subcontractors are to furnish to Essex County a duly executed Release of Lien for each progress payment as well as the Final Release, Waiver and Discharge of Lien upon payment due under the subcontract from Contractor.

Contractor shall:

- (1) Comply with its obligation as a Trustee under New York Lien Law Article 3-a,
- (2) Upon receipt of each progress payment, and upon final payment, expend the funds received as required by said Article 3-a, and in particular number 71 thereof,
- (3) Upon request by Essex County for proof of such compliance,
- (4) Defend, indemnify and hold harmless Essex County from any claims, suits, demands or judgments arising out of any failure to so comply.

In addition to the insurance requirements set forth at Appendix C, liability insurance shall include all major divisions of coverage and be on comprehensive basis including, but not limited to:

- (1) Premises operations (including X, C & U coverage as applicable),
- (2) Independent Contractors Protective,
- (3) Products and completed operations,
- (4) Personal injury liability with employment exclusion deleted,
- (5) Contractual, including specific provisions for Contractors obligation to indemnify and defend Essex County,
- (6) Owned, non-owned and hired motor vehicles,
- (7) Broad formed property damage including completed operations.

8. PERFORMANCE AND PAYMENT BONDS

Contractor shall furnish to Essex County, in duplicate, and keep enforced during the term of the Contract, Performance Bonds and Payment bonds guaranteeing that Contractor will perform its obligations under the contract and will pay for all labor and materials furnished for the work and the performance of the work. Such Bonds shall be issued on Form A1A Document A312 and by a surety acceptable to Essex County, shall name Essex County as obligee and shall be in an amount equal to 100% of the contract sum. Contractor shall deliver the executed, approved bonds to Essex County with its signed contract. The Bond shall be obtained from a surety licensed to business in the State of New York and listed in the latest issue of US Treasury Circular 570. The sufficiency of the bonds is subject to the approval of Essex county, and Bonds which are deemed insufficient by Essex County may be rejected. Bonds will remain in effect for one year after final completion of the project.

9. TERMINATION BY ESSEX COUNTY FOR CONVENIENCE

Notwithstanding any of the provision to the contrary in this Agreement or these supplemental conditions, Essex County reserved a right at any time and in its absolute discretion to terminate the services of Contractor and the work by giving written notice to Contractor. In such event, Contractor shall be entitled to, and Essex County shall reimburse Contractor for an equitable portion of Contractor's fee based on the portion of the work completed before the effective date of termination and for any other costs attributed to such termination. Contractor's entitlement to payment for all such work shall be predicated on its performance of such work in accordance with these contract documents as certified by Essex County, its Architect or Construction Manager. Contractor shall be entitled to no other payment and waives any claim for damages.

10. INSURANCE REQUIREMENTS

Contractor and each of its subcontractors shall provide Workers Compensation and Disability Insurance, Commercial General Liability Insurance, Commercial Automobile Insurance, Umbrella/Excess Liability Insurance, Special Protective and Highway Liability, Contractor's Risk and all other required insurance shall be pursuant to those requirements set forth in the New York State Department of Transportation Standard Specifications (USC) dated May 1, 2016, more particularly at pages 140-146.

In addition to the above, the insurance shall list the County of Essex as an additional insured on a primary and non-contributory basis and certificate holder. All policies will also contain no exclusions with respect to Sections 240 and 241 of the NYS Labor Law, Contractor and subcontractors waive all rights of subrogation against Essex County and will have the General Liability, Umbrella Liability and Workers Compensation Policies endorsed setting forth this waiver of subrogation. Contractor agrees to indemnify Essex County from all applicable deductibles.

11. Contractor agrees to comply with any and all rules, regulations, procedures, laws and statutes relative to federal aid and local projects.

12. DEFENSE & INDEMNIFICATION

The Contractor shall defend, indemnify and hold harmless the County to the fullest extent allowed by law, and notwithstanding any insurance requirements, from and against any and all liability, losses, claims, actions, demands, damages, expenses, suits, judgments, orders, causes of action and claims, including but not limited to attorney's fees, legal costs and all other costs of defense, by reason of any liability whatsoever imposed by law or otherwise upon the County for damages to person, property or of any other kind in nature, including but not limited to those for bodily injury, property damage, death arising out of or in connection with its officers, employees, agents, contractors, subcontractors, guests or invitees negligence or its/their performance or failure to perform this agreement.

13. COUNTY'S RIGHT TO SET-OFF

The County shall have all of its common law, equitable and statutory rights of set-off. These rights shall include, but not be limited to, the County's option to withhold for the purposes of set-off any monies due to the Contractor under this agreement up to any amounts due and owing to the County with regard to this contract, any other contract with any County department or agency, including any contract for a term commencing prior to the term of this contract, plus any amounts due and owing to the County for any other reason, including, without limitation, tax delinquencies, fee delinquencies or monetary penalties relative thereto. The County shall exercise its set-off rights in accordance with normal County practices, including, in cases of set-off pursuant to an audit, the acceptance of such audit by the County Board of Supervisors or its designated representative.

14. Contractor shall comply with any and all applicable rules, laws, standards and specifications required with respect to federal-aid highways and Marchiselli-aid local projects, both federal and New York State, including any applicable New York State Department of Transportation Specifications (USC) dated May 1, 2016, as they relate to this project. In the event of any conflict between this Agreement and the New York State Department of Transportation Specifications (USC) dated May 1, 2016, the New York State Department of Transportation Specifications shall supersede and control.

APPENDIX D - STANDARD CLAUSES FOR ESSEX COUNTY CONTRACTS

1. Independent Contractor Status

The parties each acknowledge, covenant and agree that the relationship of the Contractor to the County shall be that of an independent contractor. The Contractor, in accordance with its status as an independent contractor, further covenants and agrees that it:

- (a) will conduct itself in accordance with its status as an independent contractor;
- (b) will neither hold itself out as nor claim to be an officer or employee of the County; and
- (c) will not make any claim, demand or application for any right or privilege applicable to an officer or employee of the County, including but not limited to workers' compensation benefits, unemployment insurance benefits, social security coverage or retirement membership or credits.

2. Contractor To Comply With Laws/Regulations

The Contractor shall at all times comply with all applicable state and federal laws, rules and regulations governing the performance and rendition of the services to be furnished under this agreement.

3. Licenses, Permits, Etc.

The Contractor shall, during the term of this agreement, obtain and keep in full force and effect any and all licenses, permits and certificates required by any governmental authority having jurisdiction over the rendition and performance of the services to be furnished by the Contractor under this agreement.

4. Termination

This agreement may be terminated without cause by either party upon 30 days prior written notice, and upon such termination neither party shall have any claim or cause of action against the other except for services actually performed and mileage expenses actually incurred prior to such termination. Notwithstanding the foregoing, this agreement may be immediately terminated by the County:

- (a) for the Contractor's breach of this agreement, by serving written notice of such termination stating the nature of the breach upon the Contractor by personal delivery or by certified mail, return receipt requested, and upon such termination either party shall have such rights and remedies against the other as provided by law; or
- (b) upon the reduction or discontinuance of funding by the State or Federal governments to be used in furnishing some or all of the work, labor and/or services provided for under this agreement, and upon such termination neither party shall have any claim or cause of action against the other except for services actually performed and expenses (if the same are to be paid under this agreement) actually incurred prior to such termination.

5. Defense & Indemnification

The Contractor shall defend, indemnify and hold harmless the County to the fullest extent allowed by law, and notwithstanding any insurance requirements, from and against any and all liability, losses, claims, actions, demands, damages, expenses, suits, judgments, orders, causes of action and claims, including but not limited to attorney's fees, legal costs, and all other costs of defense, by reason of any liability whatsoever imposed by law or otherwise upon the County for damages to person, property or of any other kind in nature, including but not limited to those for bodily injury, property damage, death arising out of or in connection with its officers, employees, agents, contractors, sub-contractors, guests or invitees negligence or its/their performance or failure to perform this agreement. This language shall

be inserted by Contractor in all agreements between Contractor and its subcontractors and subcontractors will indemnify and hold harmless the County pursuant to its terms.

6. **Discrimination Prohibited**

The services to be furnished and rendered under this agreement by the Contractor shall be available to any and all residents of Essex County without regard to race, color, creed, sex, religion, national or ethnic origin, handicap, or source of payment; and under no circumstances shall a resident's financial ability to pay for the services provided be considered unless such consideration is allowed by State and/or Federal law, rule or regulation.

7. **Non-Discrimination In Employment**

The Contractor will not discriminate against any employee or applicant for employment because of race, creed, color, sex, national origin, age, disability or marital status. In the event that this is a contract to be performed in whole or in part within the State of New York for (a) the construction, alteration or repair of any public building or public work, (b) for the manufacture, sale or distribution of materials, equipment or supplies, (c) for building service, the Contractor agrees that neither it nor its subcontractors shall, by reason of race, creed, color, disability, sex or national origin:

- (1) discriminate in hiring against any citizen who is qualified and available to perform the work; or
- (2) discriminate against or intimidate any employee hired for the performance of work under this contract.

The Contractor agrees to be subject to fines of \$50.00 per person per day for any violation of this paragraph, as well as to possible termination of this contract or forfeiture of all moneys due hereunder for a second or subsequent violation.

8. **Damage/Injury To Persons & Property**

The Contractor shall promptly advise the County of all damages to property of the County or of others, or of injuries incurred by persons other than employees of the Contractor, in any manner relating, either directly or indirectly, to the performance of this agreement.

9. **Records**

The Contractor shall establish and maintain complete and accurate books, records, documents, accounts and other evidence directly pertinent to performance under this contract (hereinafter collectively "the Records") in accordance with the following requirements:

- (a) the Records must be kept for the balance of the calendar year in which they were made and for six (6) additional years thereafter;
- (b) the County Auditor, State Comptroller, the Attorney General or any other person or entity authorized to conduct an examination, as well as the agency or agencies involved in this contract, shall have access to the Records during normal business hours at an office of the Contractor within the State of New York, or, if no such office is available, at a mutually agreeable and reasonable venue within the State, for the term specified above for the purposes of inspection, auditing and copying.

The County shall take reasonable steps to protect from public disclosure any of the records which are exempt from disclosure under Section 87 of the Public Officers Law (the "Statute") provided that: (i) the Contractor shall timely inform an appropriate County official, in writing, that said records should not be disclosed; and (ii) said records shall be sufficiently identified and designation of said records as exempt under the statute is reasonable. Nothing

contained herein shall diminish, or in any way adversely affect, the County's right to discovery in any pending or future litigation.

10. **Claims For Payment**

All invoices or claims for which payment is sought from the County must be submitted in accordance with the following:

- (a) each claim for payment must include
 - (1) an invoice detailing the claim,
 - (2) copies of all documentation supporting the claim,
 - (3) a properly completed County standard voucher, which includes
 - (i) the County contract number under which payment is being claimed, **AND**
 - (ii) the payee's Federal employer identification number or Federal social security number, or both such numbers when the payee has both such numbers. *[Failure to include this number or numbers will prevent and preclude payment by the County; except that where the payee does not have such number or numbers, the payee, on the invoice or County voucher, must give the reason or reasons why the payee does not have such number or numbers and such reasons constitute a valid excuse under law.]*
- (b) Unless otherwise provided in this agreement, each claim for payment must be submitted to the County no later than 30 days after the work, labor, materials, and/or services for which payment is claimed were rendered or furnished.
- (c) Notwithstanding any other provision of this agreement, no claim for payment shall be valid, and the County shall not be liable for payment thereof, unless it is submitted to the County within 30 days of the close of the calendar year in which the work, labor, materials, and/or services for which payment is claimed were rendered or furnished.
- (d) Unless otherwise provided in this agreement, the requirements of this paragraph 10, and/or of any other provisions of this agreement which supersede the same, shall constitute conditions precedent to the County's payment obligation, and failure to comply with any or all of said requirements shall entitle the County to deny payment.
- (e) As a further condition of payment, each claim of payment shall be accompanied by a Contractor and Sub-Contractor Progress Payment Waiver, Release and Discharge, and each Final Payment shall be accompanied by a Contractor and Sub-Contractor Final Payment, Waiver and Release form. As well as a Contractor Affidavit relative to Final Payment. Copies of these forms are attached and made a part hereof. (Please disregard if these forms do not pertain).

11. **Consent**

In the event that State or Federal law requires the recipient of services to be furnished and rendered under this agreement to give his/her prior consent thereto, the contractor shall obtain such person's consent and furnish proof thereof to the County.

12. **Executory Clause**

The County shall have no liability under this contract to the Contractor or to anyone else beyond the funds appropriated and available for this contract.

13. **Public Work & Building Service Contract Requirements**

If this is a public work contract covered by Article 8 of the Labor Law or a building service contract covered by Article 9 thereof:

- (a) neither the Contractor's employees nor the employees of its subcontractors may be required or permitted to work more than the number of hours or days stated in said

- statutes, except as otherwise provided in the Labor Law and as set forth in prevailing wage and supplement schedules issued by the State Labor Department; and
- (b) the Contractor and its subcontractors must pay at least the prevailing wage rate and pay or provide the prevailing supplements, including the premium rates for overtime pay, as determined by the State Labor Department in accordance with the Labor Law.

14. **Public Work Contracts – Hazardous Substances**

If this is a contract for public work, the Contractor agrees as follows:

- (a) the Contractor acknowledges that the County uses and/or produces various substances which may be classified as hazardous under OSHA's Hazard Communication Standard;
- (b) the Contractor recognizes the use of said substances by the County and acknowledges that the County has provided, or upon request will provide, the Contractor with a description of such substances which may be present in the area of the County's facility/facilities to which the Contractor may have accessed during the performance of this contract;
- (c) the Contractor acknowledges that the County has provided, or upon request will provide, suggestions for appropriate protective measures which should be observed when the Contractor is in the area of any such hazardous substances;
- (d) the Contractor agrees to be solely responsible for providing training and information to its employees regarding any such hazardous substances, as well as of any protective measures suggested by the County;
- (e) the Contractor agrees to be solely responsible to ensure that the Contractor's employees observe protective measures during the performance of their duties in the performance of the contract, and that all such protective measures will be at least as stringent as those suggested or which would have been suggested by the County;
- (f) in the event that the Contractor's performance of the work under this contract requires the use of any hazardous substances, the Contractor shall notify the County in advance of bringing in and/or using such substances in or upon County property and suggest to the County appropriate measures to be observed by the County, its officers and employees, and/or the public; and
- (g) in the event the Contractor fails in whole or in part to comply with the terms of this paragraph, the County shall have the right to interrupt the Contractor's work and/or terminate this contract, and the Contractor shall be prohibited from renewing such work until all applicable safety and health procedures and practices are implemented by the Contractor.

15. **Disputes**

Disputes involving this contract, including the breach or alleged breach thereof, may not be submitted to binding arbitration, but must, instead, be heard in the Essex County Supreme Court or any other court of competent jurisdiction within Essex County, New York.

16. **Non-Assignment**

This agreement may not be assigned, subcontracted, transferred, conveyed, sublet or otherwise disposed of in whole or in part, by the Contractor, without the prior written consent of the County, and any attempts to assign the contract without the County's written consent are null and void.

17. **No Collusion**

If this contract was awarded based upon the submission of bids, the Contractor warrants, under penalty of perjury, that:

- (a) its bid was arrived at independently and without collusion aimed at restricting competition; and
- (b) at the time Contractor submitted its bid, an authorized and responsible person executed and delivered to the County a non-collusive bidding certification on Contractor's behalf.

18. **International Boycott**

In accordance with Section 220-f of the Labor Law, if this contract exceeds \$5,000.00, the Contractor agrees, as a material condition of the contract, that neither the Contractor nor any substantially owned or affiliated person, firm, partnership or corporation, has participated, is participating, or shall participate in an International boycott in violation of the federal Export Administration Act of 1979, or regulations thereunder. If such contractor, or any of the aforesaid affiliates of Contractor, is convicted, or is otherwise found to have violated said laws or regulations upon the final determination of the United States Commerce Department or any other appropriate agency of the United States subsequent to the contract's execution, such contract, amendment or modification thereto shall be rendered forfeit and void. The Contractor shall so notify the County Manager within five (5) business days of such conviction, determination or disposition of appeal.

19. **County's Rights of Set-Off**

The County shall have all of its common law, equitable and statutory rights of set-off. These rights shall include, but not be limited to, the County's option to withhold for the purposes of set-off any moneys due to the Contractor under this agreement up to any amounts due and owing to the County with regard to this contract, any other contract with any County department or agency, including any contract for a term commencing prior to the term of this contract, plus any amounts due and owing to the County for any other reason, including, without limitation, tax delinquencies, fee delinquencies or monetary penalties relative thereto. The County shall exercise its set-off rights in accordance with normal County practices, including, in cases of set-off pursuant to an audit, the acceptance of such audit by the County Board of Supervisors or its designated representative.

20. **Contractor Defined**

Whenever the term "Contractor" is used in this agreement, such term shall include and apply to all employees, all officers, directors and agents, if any, of the Contractor.

21. **Amendment**

This agreement may not be amended, modified or renewed except by written agreement signed by the Contractor and the County.

22. **Ownership Of Work Products**

All final and written or tangible work products completed by the Contractor shall belong to the County. In the event of premature discontinuance of performance, the Contractor agrees to deliver all existing products and data files to the County.

23. **Executive Order Debarment/Suspension**

In the event that this contract involves the Contractor furnishing goods and services in excess of \$100,000.00, or constitutes a subaward to subrecipients, under any Federal program, grant or other funding source, then by executing this agreement the Contractor certifies that neither it nor any of its principals are suspended or debarred within the scope or meaning of Executive Orders 12549 and 12689, any Federal or State regulation implementing or codifying the same, or any other Federal or State law, rule or regulation.

24. **Health Insurance Portability and Accountability Act of 1996 (HIPAA)**

In the event that this contract involves the use or disclosure of protected health information within the meaning or application of the Health Insurance Portability and Accountability Act of 1996 (HIPAA), and the regulations thereunder, the following provisions of this paragraph shall apply.

- (a) **Definitions.** The terms used, but not otherwise defined, in this Agreement shall have the same meaning as given such terms in 45 CFR §160.103 and §164.501, as the same may be amended from time to time, including but not limited to the following.
- (1) "Business Associate" shall mean the Contractor, its officers, employees, agents and subcontractors.
 - (2) "Covered Entity" shall mean Essex County (the "County"), its departments, agencies, officers and employees.
 - (3) "Individual" shall have the same meaning as given such term in 45 CFR §164.501 and shall also include a person who qualifies as a personal representative in accordance with 45 CFR §164.502(g).
 - (4) "Privacy Rule" shall mean the Standards for Privacy of Individually Identifiable Health Information at 45 CFR Part 160 and Part 164, subparts A and E.
 - (5) "Protected Health Information" shall have the same meaning as given such term in 45 CFR §164.501, limited to the information created or received by Contractor from or on behalf of the County.
 - (6) "Required by law" shall have the same meaning as given such term in 45 CFR §164.501.
 - (7) "Secretary" shall mean the Secretary of the Department of Health and Human Services or his/her designee.
- (b) **Obligations and Activities of Contractor.**
Contractor agrees to:
- (1) not use or disclose Protected Health Information other than as permitted or required by this Agreement or as required by law;
 - (2) use appropriate safeguards to prevent use or disclosure of the Protected Health Information other than as provided for by this Agreement;
 - (3) mitigate, to the extent practicable, any harmful effect that is known, should have been known, and/or discovered to/by Contractor of a use or disclosure of Protected Health Information by Contractor in violation of the requirements of this Agreement;
 - (4) report to the County any use or disclosure of the Protected Health Information not provided for by this Agreement of which it becomes aware;
 - (5) ensure that any agent, including a subcontractor, to whom it provides Protected Health Information received from, or created or received by Contractor on behalf of the County agrees to the same restrictions and conditions that apply through this Agreement to Contractor with respect to such information;
 - (6) provide access, at the request of the County, and in the time and manner designated by the County or the Secretary, to Protected Health Information in a Designated Record Set, to the County or, as directed by the County, to an Individual in order to meet the requirements under 45 CFR §164.524;
 - (7) make any amendment(s) to Protected Health Information in a Designated Record Set that the County directs or agrees to pursuant to 45 CFR §164.526 at the request of the County or an Individual, and in the time and manner designated by the County or the Secretary;

- (8) make internal practices, books, and records, including policies and procedures and Protected Health Information, relating to the use and disclosure of Protected Health Information received from, or created or received by Contractor on behalf of, the County available to the County, and/or to the Secretary, in a time and manner designated by the County or by the Secretary, for purposes of the Secretary determining the County's compliance with the Privacy Rule;
- (9) document such disclosures of Protected Health Information and information related to such disclosures as would be required for the County to respond to a request by an Individual for an accounting of disclosures of Protected Health Information in accordance with 45 CFR §164.528;
- (10) provide to the County or an Individual, in time and manner designated by the County or the Secretary, information collected in accordance with the above subparagraph (b)(9) of this Agreement, to permit the County to respond to a request by an Individual for an accounting of disclosures of Protected Health Information in accordance with 45 CFR §164.528.

(c) Permitted Uses and Disclosures by Contractor.

Except as otherwise limited in this Agreement, Contractor may use or disclose Protected Health Information on behalf of, or to provide services to, the persons entitled to services under this Agreement:

- (1) solely for the purposes of performing Contractor's obligations under this Agreement, if such use or disclosure of Protected Health Information would not violate the Privacy Rule if done by the County or the minimum necessary policies and procedures of the County; or
- (2) provided that such use or disclosures are required by law; or
- (3) Contractor
 - (A) obtains written authorization(s) from the individual to which the information pertains permitting the specific uses or disclosures of such information to third persons,
 - (B) represents and agrees in writing with such individual that the information to be used and/or disclosed will remain confidential and used or further disclosed only as required by law or for the purposes specified in the written authorization(s), and
 - (C) such third persons agree in writing to notify the County as soon as practicable and in writing of any instances of which such third person(s) is/are aware in which the confidentiality of the information has been breached; or
- (4) provide Data Aggregation services to the County as permitted by 42 CFR §164.504(e)(2)(i)(B); or
- (5) report violations of law to appropriate Federal and State authorities, consistent with §164.502(j)(1).

(d) County To Inform Contractor of Privacy Practices and Restrictions.

The County agrees to notify the Contractor of any

- (1) limitation(s) in its notice of privacy practices of the County in accordance with 45 CFR §164.520, to the extent that such limitation may affect the Contractor's use or disclosure of Protected Health Information;
- (2) changes in, or revocation of, permission by Individual to use or disclose Protected Health Information, to the extent that such changes may affect the Contractor's use or disclosure of Protected Health Information; and/or
- (3) restriction to the use or disclosure of Protected Health Information that the

County has agreed to in accordance with 45 CFR §164.522, to the extent that such restriction may affect Contractor's use or disclosure of Protected Health Information.

(e) Permissible Requests by County.

The County shall not request Contractor to use or disclose Protected Health Information in any manner that would not be permissible under the Privacy Rule if done by the County; except that in the event that the services to be furnished by the Contractor under this Agreement requires data aggregation by the Contractor, the Contractor may use or disclose protected health information for such data aggregation or management and administrative activities of Contractor.

(f) Survival of Provisions.

The obligations of the Contractor under this paragraph 24 shall survive the expiration of the term of this Agreement and/or the termination of this Agreement, and said obligations shall remain effective and shall not terminate until all of the Protected Health Information provided by the County to Contractor, or created or received by Contractor on behalf of the County, is destroyed or returned to the County, or, if it is infeasible to return or destroy Protected Health Information, protections are extended to such information, in accordance with the termination provisions in subparagraph (g) below.

(g) Return or Destruction of Protected Health Information.

Except as otherwise provided below, upon termination of this Agreement for any reason, Contractor shall return or destroy all Protected Health Information received from the County, or created or received by Contractor on behalf of the County. This provision shall apply to Protected Health Information that is in the possession of subcontractors or agents of Contractor. Contractor shall retain no copies of the Protected Health Information.

In the event that Contractor determines that returning or destroying the Protected Health Information is infeasible, Contractor shall provide to the County notification of the conditions that make return or destruction infeasible. Upon determination by the County that return or destruction of Protected Health Information is infeasible, Contractor shall extend the protections of this Agreement to such Protected Health Information and limit further uses and disclosures of such Protected Health Information to those purposes that make the return or destruction infeasible, for so long as Contractor maintains such Protected Health Information.

(h) Termination for Cause.

Upon the County's knowledge of a material breach of this paragraph by Contractor, the County shall:

- (1) either:
 - (A) provide an opportunity for Contractor to cure the breach or end the violation and terminate this Agreement within the time specified by the County, or
 - (B) immediately terminate this Agreement if cure is not possible; and
- (2) report the violation to the Secretary.

(i) Miscellaneous.

- (1) Regulatory References. A reference in this Agreement to a section in the Privacy Rule means the section as in effect or as amended.
- (2) Amendment. The Parties agree to take such action as is necessary to amend this Agreement from time to time as is necessary for the County to comply with the requirements of the Privacy Rule and the Health Insurance Portability and Accountability Act of 1996, Pub. L. No. 104-191.

- (3) Survival. The respective rights and obligations of Contractor under this paragraph 24 of this Agreement shall survive the termination of this Agreement.
- (4) Interpretation. Any ambiguity in this Agreement shall be resolved to permit the County to comply with the Privacy Rule.

25. **Severability**

If any term or provision of this agreement or the application thereof to any person or circumstance shall to any extent be held invalid or unenforceable, the remainder of this agreement or the application of such term or provision to persons or circumstances other than those as to which it is held invalid or unenforceable, shall not be affected thereby and every other term and provision of this agreement shall be valid and be enforced to the fullest extent permitted by law.

26. **Entire Agreement**

This agreement is the entire agreement between the parties, and the same shall be construed in accordance with the laws of the State of New York.

27. **For Medicaid/Federal Health Care Related Work**

Excluded/Debarred Party Clause

The Vendor/Contractor represents and warrants that it, nor its employees or contractors, are not excluded from participation, and is not otherwise ineligible to participate, in a "federal health care program" as defined in 42 U.S.C. § 1320a-7b(f) or in any other government payment program.

In the event Vendor/Contractor, or one of its employees or contractors, is excluded from participation, or becomes otherwise ineligible to participate in any such program during the Term, Vendor/Contractor will notify Essex County in writing within three (3) days after such event. Upon the occurrence of such event, whether or not such notice is given to the Vendor/Contractor, Essex County reserves the right to immediately cease contracting with the Vendor/Contractor.

If Vendor/Contractor is an Employment Agency, the Vendor/Contractor represents and warrants that its employees and contractors are not excluded from participation in a "federal health care program" as defined in 42 U.S.C. § 1320a-7b(f) or debarred from participation in any federal or other program.

- The Vendor/Contractor further represents and warrants it will, at a minimum, check monthly all of its employees and subcontractors against:
- The General Services Administration's Federal Excluded Party List System (or any successor system),
- The United States Department of Health and Human Services' Office of the Inspector General's Lists of Excluded Individuals and Entities or any successor list,

The New York State Department of Health's Office of the Medicaid Inspector General's list of Restricted, Terminated or Excluded Individuals or Entities.

In the event an excluded party is discovered the Vendor/Contractor will notify Essex County in writing within three (3) days after such event. Upon the occurrence of such event, whether or not such notice is given to the Vendor/Contractor, Essex County reserves the right to immediately cease contracting with the Vendor/Contractor.

28. **Cooperative Purchasing (Piggybacking)**

Pursuant to General Municipal Law §103 and County Law §408-a, any political sub-

division or fire company (as both are defined in Section 100 of the GML) or district authorized to make purchases of apparatus, materials, equipment or supplies, or to contract for services related to the installation, maintenance or repair of apparatus, materials, equipment and supplies may make said purchases under this existing contract (Piggyback) provided, and on condition that this present contract was **LET TO THE LOWEST RESPONSIBLE BIDDER**. Therefore all terms and conditions under this contract are extended to other political sub-divisions and governmental entities.

Purchases under this contract by any other political sub-division other than Essex County shall be pursuant to the terms and conditions of Resolution No. 207 of 2013 dated July 1, 2013.

29. **New York State Sexual Harassment Laws**

Contractor certifies as to its self or its own organization, under penalty of perjury, that Contractor has and has implemented a written policy addressing sexual harassment prevention in the workplace and provides annual sexual harassment prevention training to all of its employees. Such policy shall, at a minimum, meet the requirements of Section 201-g of the New York State Labor Law. A model policy and training has been created by the New York State Department of Labor and can be found here:
<https://www.ny.gov/programs/combating-sexual-harassment-workplace>.

CONTRACTOR PROGRESS PAYMENT WAIVER, RELEASE AND DISCHARGE

PROJECT: _____

OWNER: ESSEX COUNTY

CONTRACTOR: _____

WITNESSETH:

The above-named Contractor, hereinafter referred to as the "Releasor", does, for and on behalf of itself, its' successors, assigns and all parties claiming any interest or right through the Releasor, hereby warrant, covenant and agree as follows:

1. Releasor is/was a Contractor relative to the above-referenced Project pursuant to a contract or other relationship for the performing and/or furnishing of work, labor, services, materials and/or equipment at the Project site or to be incorporated in said Project.

2. Whenever the term "Releasor" is used in this instrument such term shall mean: (a) the above-named Contractor, its, successors and assigns; (b) any and all sureties and all other guarantors of the Releasor on any payment, performance, labor and/or material bond or other undertaking; (c) all parties claiming any interest or right through the Releasor, including but not limited to subcontractors and suppliers; and (d) the respective officers, directors, principals, shareholders, agents, employees and attorneys of (a), (b) and (c).

3. Whenever the term "Releasees" is used in this instrument such term shall mean: (a) the above-named Owner, its' successors and assigns; (b) the Project Architect/Engineer; and (c) the respective officers, directors, principals, shareholders, agents, employees and attorneys of (a) and (b).

4. For and in consideration of the sum of \$_____, and other good and valuable consideration, which sum is acknowledged as being the full and total amount due or allegedly due or owing from the Releasees to the Releasor as of the date hereof, and the receipt of such payment being hereby acknowledged, the Releasor does waive, release and discharge the Releasees from any and all causes of action, suits, debts, claims, liens, accounts, bonds, contracts, damages, encumbrances, judgments and demands whatsoever and of every kind and nature, in law or in equity, which against the Releasees, jointly and/or severally, the Releasor ever had, now has, or might hereafter have, relating directly or indirectly to the work, labor, services, materials and/or equipment furnished and/or performed at the Project site, or incorporated or to be incorporated in said Project, as of the date hereof, including but not in any manner limited to the right of the Releasor to assert, file or claim any lien or other security interest in or upon the real and/or personal property of the Releasees.

5. The Releasor hereby agree to defend, indemnify, and hold harmless the Releasees from any and all damages, costs, expenses, demands, suits, liens and legal fees, directly or indirectly relating to any claim for compensation by any other party for work, labor, services, materials and/or equipment furnished and/or performed at the Project site, or which should have been so furnished or performed, or incorporated or to be incorporated in said Project, as of the date hereof, by the Releasor or by any other party claiming any interest or right through the Releasor.

6. The Releasor hereby certifies and warrants that it has fully paid for all work, labor, services, materials and/or equipment provided to it in connection with the Project and/or any contract relating thereto.

7. The Releasor hereby grants to the Releasees the right to review and audit any and books and records of the Releasor at any time for verification.

IN WITNESS WHEREOF this instrument has been executed this ____ day of _____
_____ 20 ____.

Releasor

By: _____

Print Name

Title

STATE OF NEW YORK)
) SS:
COUNTY OF ESSEX)

I, _____, being duly sworn, depose and say that: I reside at _____, and I hereby sign this instrument under penalty of perjury; I am the of the Releasor identified herein; I am fully authorized to execute this instrument on behalf of the Releasor; and I hereby affirm that the statements contained in this instrument are true and correct.

Vendor/Releasor Agent Sign Here

Sworn to before me this _____
day of _____, 20__

Notary Public

CONTRACTOR FINAL PAYMENT WAIVER, RELEASE AND DISCHARGE

PROJECT: _____

OWNER: _____

CONTRACTOR: _____

WITNESSETH:

The above-named Contractor, hereinafter referred to as the "Releasor", does, for and on behalf of itself, its' successors, assigns and all parties claiming any interest or right through the Releasor, hereby warrants, covenants and agrees as follows:

1. Releasor is/was a Contractor relative to the above-referenced Project pursuant to a contract or other relationship for the performing and/or furnishing of work, labor, services, materials and/or equipment at the Project site or to be incorporated in said Project.

2 Whenever the term "Releasor" is used in this instrument such term shall mean: (a) the above- named Contractor, its, successors and assigns; (b) any and all sureties and all other guarantors of the Releasor on any payment, performance, labor and/or material bond or other undertaking; (c) all parties claiming any interest or right through the Releasor, including but not limited to subcontractors and suppliers; and (d) the respective officers, directors, principals, shareholders, agents, employees and attorneys of (a), (b) and (c).

3. Whenever the term "Releasees" is used in this instrument such term shall mean: (a) the above-named Owner, its' successors and assigns; (b) Essex County, its agencies and departments (including but not limited to its Office for the Aging); and (c) the respective officers, directors, principals, shareholders, agents, employees and attorneys of (a) and (b).

4. For and in consideration of the sum of \$_____, and other good and valuable consideration, which sum is acknowledged as being the full, final and total amount due or allegedly due or owing from the Releasees to the Releasor as of the date hereof, and the receipt of such payment being hereby acknowledged, the Releasor does waive, release and discharge the Releasees from any and all causes of action, suits, debts, claims, liens, accounts, bonds, contracts, damages, encumbrances, judgments and demands whatsoever and of every kind and nature, in law or in equity, which against the Releasees, jointly and/or severally, the Releasor ever had, now has, or might hereafter have, relating directly or indirectly to the work, labor, services, materials and/or equipment furnished and/or performed at the Project site, or incorporated or to be incorporated in said Project, as of the date hereof, including but not in any manner limited to the right of the Releasor to assert, file or claim any lien or other security interest in or upon the real and/or personal property of the Releasees.

5. The Releasor hereby agree to defend, indemnify, and hold harmless the Releasees from any and all damages, costs, expenses, demands, suits, liens and legal fees, directly or indirectly relating to any claim for compensation by any other party for work, labor, services, materials and/or equipment furnished and/or performed at the Project site, or which should have been so furnished or performed, or incorporated or to be incorporated in said Project, as of the date hereof, by the Releasor or by any other party claiming any interest or right through the Releasor.

6. The Releasor hereby certifies and warrants that it has fully paid for all work, labor, services, materials and/or equipment provided to it in connection with the Project and/or any contract relating thereto.

7. The Releasor hereby grants to the Releasees the right to review and audit any and books and records of the Releasor at any time for verification.

IN WITNESS WHEREOF this instrument has been executed this ___ day of _____, 20__.

Releasor

By: _____

Print Name

Title

STATE OF NEW YORK)
) SS:
 COUNTY OF ESSEX)

I, _____, being duly sworn, depose and say that: I reside at _____, and I hereby sign this instrument under penalty of perjury; I am the of the Releasor identified herein; I am fully authorized to execute this instrument on behalf of the Releasor; and I hereby affirm that the statements contained in this instrument are true and correct.

 Vendor/Releasor Agent Sign Here

Sworn to before me this _____
 day of _____, 20__.

 Notary Public

CONTRACTORS AFFIDAVIT RELATIVE TO FINAL PAYMENT

PROJECT: _____

OWNER: ESSEX COUNTY

CONTRACTOR: _____

W I T N E S S E T H :

The herein below designated representative of the Contractor being duly sworn deposes and states:

1. He is duly authorized to sign this Affidavit on behalf of the Contractor.

2. That all payrolls, bills for materials and equipment, and other indebtedness connection with the work for which the County or the County's property might be responsible or encumbered have been paid or otherwise satisfied and there remain no further indebtedness or bills outstanding.

3. Attached hereto and made a part hereof is a valid certificate of insurance evidencing that insurance required by the contract documents will remain in full force after final payment is currently in effect and will not be cancelled or allowed to expire until at least 30 days prior written notice has been given to the owner.

4. Contractor knows of no substantial reason that the insurance will not be renewable to cover the period required by the contract documents.

5. Attached hereto and made a part hereof at Schedule B is a detailed list of all sub-contractors and material suppliers.

6. Contractor warrants and represents that all sub-contractors, material suppliers and fringe benefit trust funds for employees of contractor and sub-contractors on the portion of the project encompassed by the work, as well as all workers and persons employed in connection therewith have been paid in full for all labor and work and materials furnished.

7. Contractor releases and waives any and all public improvement lien rights which contractor has against the County.

IN WITNESS WHEREOF deponent has executed this Document on this _____ day
of _____, 20__.

Contractor

By: _____
Print Name

Title

STATE OF NEW YORK)
) SS:
COUNTY OF ESSEX)

I, _____, being duly sworn, depose and say that: I reside at _____, and I hereby sign this instrument under penalty of perjury; I am the of the Releasor identified herein; I am fully authorized to execute this instrument on behalf of the Releasor; and I hereby affirm that the statements contained in this instrument are true and correct.

Vendor/Releasor Agent Sign Here

Sworn to before me this ____
day of _____, 20__.

Notary Public

SUBCONTRACTOR/SUPPLIER PROGRESS PAYMENT WAIVER, RELEASE AND DISCHARGE

PROJECT: _____

OWNER: ESSEX COUNTY

CONTRACTOR: _____

SUBCONTRACTOR/SUPPLIER: _____

WITNESSETH:

The above-named Subcontractor/Supplier, hereinafter referred to as the "Releasor", does, for and on behalf of itself, its, successors, assigns and all parties claiming any interest or right through the Releasor, hereby warrants, covenants and agrees as follows:

1. Releasor is/was a subcontractor/supplier to the Contractor above-named relative to the above-referenced Project pursuant to a contract or other relationship for the performing and/or furnishing of work, labor, services, materials and/or equipment at the Project site or to be incorporated in said Project.

2. Whenever the term "Releasor" is used in this instrument such term shall mean: (a) the above-named Subcontractor/Supplier, its' successors and assigns; (b) any and all sureties and all other guarantors of the Releasor on any payment, performance, labor and/or material bond or other undertaking; (c) all parties claiming any interest or right through the Releasor; and (d) the respective officers, directors, principals, shareholders, agents, employees and attorneys of (a), (b) and (c).

3. Whenever the term "Releasees" is used in this instrument such term shall mean: (a) the above-named Contractor and all of its, sureties and other guarantors on any payment, performance, labor and/or material bond or other undertaking; (b) the abovenamed Owner, its, successors and assigns; (c) the Project Architect/Engineer; and (d) the respective officers, directors, principals, shareholders, agents, employees and attorneys of (a), (b) and (c).

4. For and in consideration of the sum of \$ _____, and other good and valuable consideration, which sum is acknowledged as being the full and total amount due or allegedly due or owing from the Releasees to the Releasor as of the date hereof, and the receipt of such payment being hereby acknowledged, the Releasor does waive, release and discharge the Releasees from any and all causes of action, suits, debts, claims, liens, accounts, bonds, contracts, damages, encumbrances, judgments and demands whatsoever and of every kind and nature, in law or in equity, which against the Releasees, jointly and/or severally, the Releasor ever had, now has, or might hereafter have, relating directly or indirectly to the work, labor, services, materials and/or equipment furnished and/or performed at the Project site, or incorporated or to be incorporated in said Project, as of the date hereof, including but not in any manner limited to the right of the Releasor to assert, file or claim any lien or other security interest in or upon the real and/or personal property of the Releasees.

5. The Releasor hereby agree to defend, indemnify, and hold harmless the Releasees from any and all damages, costs, expenses, demands, suits, liens and legal fees, directly or indirectly relating to any claim for compensation by any other party for work, labor, services, materials and/or equipment furnished and/or performed at the Project site, or which should have been so furnished

or performed, or incorporated or to be incorporated in said Project, as of the date hereof, by the Releasor or by any other party claiming any interest or right through the Releasor.

6. The Releasor hereby certifies and warrants that it has fully paid for all work, labor, services, materials and/or equipment provided to it in connection with the Project and/or any contract relating thereto.

7. The Releasor hereby grants to the Releasees the right to review and audit any and books and records of the Releasor at any time for verification.

IN WITNESS WHEREOF this instrument has been executed this ____ day of ____
_____, 20 .

Releasor

By: _____

(Print Name)

(Title)

STATE OF NEW YORK)
) SS:
COUNTY OF ESSEX)

I, _____, being duly sworn, depose and say that: I reside at _____, and I hereby sign this instrument under penalty of perjury; I am the of the Releasor identified herein; I am fully authorized to execute this instrument on behalf of the Releasor; and I hereby affirm that the statements contained in this instrument are true and correct.

Vendor/Releasor Agent Sign Here

Sworn to before me this ____
day of _____, 20 .

Notary Public

SUBCONTRACTOR/SUPPLIER FINAL WAIVER, RELEASE AND DISCHARGE

PROJECT: _____

OWNER: ESSEX COUNTY

CONTRACTOR: _____

SUBCONTRACTOR/SUPPLIER: _____

W I T N E S S E T H :

The above-named Subcontractor/Supplier, hereinafter referred to as the "Releasor", does, for and on behalf of itself, its, successors, assigns and all parties claiming any interest or right through the Releasor, hereby warrants, covenants and agrees as follows:

1. Releasor is/was a subcontractor/supplier to the Contractor above-named relative to the above-referenced Project pursuant to a contract or other relationship for the performing and/or furnishing of work, labor, services, materials and/or equipment at the Project site or to be incorporated in said Project.

2. Whenever the term "Releasor" is used in this instrument such term shall mean: (a) the above-named Subcontractor/Supplier, its' successors and assigns; (b) any and all sureties and all other guarantors of the Releasor on any payment, performance, labor and/or material bond or other undertaking; (c) all parties claiming any interest or right through the Releasor; and (d) the respective officers, directors, principals, shareholders, agents, employees and attorneys of (a), (b) and (c).

3. Whenever the term "Releasees" is used in this instrument such term shall mean: (a) the above-named Contractor and all of its, sureties and other guarantors on any payment, performance, labor and/or material bond or other undertaking; (b) the abovenamed Owner, its, successors and assigns; (c) the Project Architect/Engineer; and (d) the respective officers, directors, principals, shareholders, agents, employees and attorneys of (a), (b) and (c).

4. For and in consideration of the sum of \$ _____, and other good and valuable consideration, which sum is acknowledged as being the full, final and total amount due or allegedly due or owing from the Releasees to the Releasor as of the date hereof, and the receipt of such payment being hereby acknowledged, the Releasor does waive, release and discharge the Releasees from any and all causes of action, suits, debts, claims, liens, accounts, bonds, contracts, damages, encumbrances, judgments and demands whatsoever and of every kind and nature, in law or in equity, which against the Releasees, jointly and/or severally, the Releasor ever had, now has, or might hereafter have, relating directly or indirectly to the work, labor, services, materials and/or equipment furnished and/or performed at the Project site, or incorporated or to be incorporated in said Project, as of the date hereof, including but not in any manner limited to the right of the Releasor to assert, file or claim any lien or other security interest in or upon the real and/or personal property of the Releasees.

5. The Releasor hereby agree to defend, indemnify, and hold harmless the Releasees from any and all damages, costs, expenses, demands, suits, liens and legal fees, directly or indirectly relating to any claim for compensation by any other party for work, labor, services, materials and/or equipment furnished and/or performed at the Project site, or which should have been so furnished

or performed, or incorporated or to be incorporated in said Project, as of the date hereof, by the Releasor or by any other party claiming any interest or right through the Releasor.

6. The Releasor hereby certifies and warrants that it has fully paid for all work, labor, services, materials and/or equipment provided to it in connection with the Project and/or any contract relating thereto.

7. The Releasor hereby grants to the Releasees the right to review and audit any and books and records of the Releasor at any time for verification.

IN WITNESS WHEREOF this instrument has been executed this ____ day of _____, _____.

Releasor

By: _____

(Print Name)

(Title)

STATE OF NEW YORK)
) SS:
COUNTY OF _____)

I, _____, being duly sworn, depose and say that: I reside at _____, and I hereby sign this instrument under penalty of perjury; I am the of the Releasor identified herein; I am fully authorized to execute this instrument on behalf of the Releasor; and I hereby affirm that the statements contained in this instrument are true and correct.

Vendor/Releasor Agent Sign Here

Sworn to before me this ____
day of _____, 20__.

Notary Public

**ESSEX COUNTY
DEPARTMENT OF PUBLIC WORKS**

8053 US Route 9
Elizabethtown NY 12932
(518) 873-6326 or (518) 873-3666
Fax: (518) 873-9195

Christopher M. Garrow
Superintendent

CHANGE ORDER

ESSEX COUNTY CONTRACT NO.:		CHANGE ORDER NO.:	
CONTRACTOR:			
PROJECT:			

DESCRIPTION OF CHANGES / ADDITIONAL WORK AUTHORIZED:	
---	--

AGREED INCREASE IN CONTRACT PRICES:		AGREED DECREASE IN CONTRACT PRICE:	
--	--	---------------------------------------	--

Pursuant to Section 9 of the above-referenced contract, I, the Essex County Superintendent of Public Works, hereby authorize the changes or additions in work described above and agree to the increase or decrease, if any and as indicated above, in the Contract Price.

Dated: _____

Christopher M. Garrow
Superintendent of Public Works

I, the duly authorized representative of the Contractor, hereby agree that the Contractor will perform/provide the changes or additions in work described above and to accept the increase or decrease, if any and as indicated above, in the Contract Price.

Dated: _____

(Signature)

(Print Name)

(Print Title)

INDEX TO
INFORMATION FOR BIDDERS

<u>DESCRIPTION</u>	<u>PAGE NO.</u>
Article 1. Description of Work and Bid Date	IFB-2
Article 2. Proposal Form	IFB-2
Article 3. Required Time for Bid	IFB-2
Article 4. No Recapitulation or Modification	IFB-2
Article 5. Bid Submission Address	IFB-2
Article 6. Pre-Bid Specification & Site Inspection	IFB-2
Article 7. Competency of Bidder	IFB-2
Article 8. Bid Security	IFB-2
Article 9. Notification of Award	IFB-2
Article 10. Time of Execution	IFB-2
Article 11. Time of Starting	IFB-2
Article 12. Bonds	IFB-2
Article 13. Insurance Requirements	IFB-3
Article 14. Blasting	IFB-4
Article 15. Wages	IFB-4
Article 16. Estimates and Payments	IFB-4
Article 17. Contract Drawings	IFB-5
Article 18. Conditions of Work	IFB-5
Article 19. Addenda and Interpretation	IFB-6
Article 20. Shown Quantities and Site Inspection	IFB-6
Article 21. Increase or Decrease of Quantities: Elimination of Items	IFB-6
Article 22. State and Local Tax Exemption	IFB-6
Article 23. Engineering Charges	IFB-7
Article 24. Apprentices	IFB-7
Article 25. Affirmative Action Provisions	IFB-7
Article 26. Certificate of Authority from State of New York	IFB-7
Article 27. Licensing Requirements	IFB-7

INFORMATION FOR BIDDERS

Proposals to be entitled to consideration must be made in accordance with the following instructions:

1. Sealed proposals for performing the work described in the **NOTICE TO BIDDERS**. The awarding of the Contract, if awarded, will be made within forty-five (45) days after the opening of bids.
2. Proposals shall be made according to the form provided therefore, and all blank spaces in the form, that apply, shall be fully filled; numbers shall be stated, both in writing and figures; the signature shall be in longhand; and the completed form shall be without interlineations, alteration or erasures.
3. No proposals will be considered unless received and on hand at the specified time, date, and address to which proposals are to be opened. Proposals en route by mail or other means but not so received and on hand will not be considered. NOTE: THERE IS NO GUARANTEED OVERNIGHT DELIVERY BEFORE 11:00 A.M. TO ELIZABETHTOWN.
4. Proposals shall not contain any recapitulation of the work to be done. No oral, telegraphic, facsimile machine, or telephone proposals or modifications will be considered.
5. Proposals shall be addressed to the address indicated in the **NOTICE TO BIDDERS**.
6. Before submitting a proposal, bidders shall carefully examine the plans and specifications, visit the site of the work, fully inform themselves as to all the conditions and limitations and shall include in the proposal a sum to cover the cost of all items included in the Contract.
7. The competency and responsibility of the bidders and of their proposed sub-contractors will be considered in making the award.
8. Each proposal shall be accompanied by a Certified Check or Bid Bond in the amount of five percent (5%) of the bid. This shall be made payable to the Essex County Treasurer. The check shall insure the County of Essex of the adherence of the bidder to his proposal, the execution of the Contract, and the furnishing of a faithful performance, labor and materials payment bond by the bidder as specified in the Contract documents, if his proposal is accepted. Bonding company and bond must be approved by the Essex County Attorney.
9. Acceptance of a proposal will be a notice in writing, signed by the Essex County Manager.
10. Any Bidder whose proposal is accepted will be required to execute the Contract within ten (10) days after Notice of Contract has been awarded to the Company.
11. Work shall not be started prior to the Award of the Contract, and the Contractor must diligently continue work without unnecessary delays and with sufficient manpower and equipment to complete the work schedule detailed in the **PROJECT SCHEDULE**.
12. The Contractor shall upon execution of the Agreement furnish and deliver to the County of Essex a faithful Performance Bond and a labor and materials Payment Bond. He shall furnish and maintain said bonds at his own expense and without expense to the County until final acceptance of the work covered by the Agreement. Each bond coverage shall be one hundred percent (100%) of the amount of the total Contract price. The furnishing of the bonds shall be a condition precedent to the effectuation of an Agreement between the County and the Contractor. The bonds shall be in a form satisfactory to the County and shall be issued by a Surety Company licensed to do business in the State of New York.

13. It is a requirement of the County of Essex that for work performed under Contract that the Contractor procure and maintain at his own expense and without expense to the County, until final acceptance of the work by the County, the insurance listed below.

Before Commencement of any work, a Certificate or Certificates of Insurance must be furnished the County in forms satisfactory to the County Attorney.

All Certificates of Insurance must provide that the policy or policies shall not be changed or canceled until after at least thirty days (30) prior written notice has been given to the County.

When required by the Department of Public Works the "XCU" exclusion of the policy or policies shall be eliminated or show proof the "XCU" is covered.

THE KINDS OF INSURANCE, LIMITS, AND/OR CONDITIONS ARE AS FOLLOWS:

A. Worker's Compensation -- statutory - covering all operations and locations involved in the Contract.

B. Comprehensive General Liability - covering all operations and locations involved in the Contract including the following coverages:

1. Premises Operations
2. Independent Contractors and Sub-Contractors
3. Products and Completed Operations.
4. Broad Form Contractual

C. Comprehensive General Liability - covering all operations and locations involved in the Contract, including the following coverages:

1. Owned Automobiles
2. Hired Automobiles
3. Non-owned Automobiles.

Unless specifically required, each policy shall provide limits of not less than:

Bodily Injury Liability-per occurrence - single limit of \$1,000,000.00

Property Damage Liability-per occurrence - single limit of \$1,000,000.00

D. New York State Disability Benefits - Statutory

STANDARD INSURANCE REQUIREMENTS AND INDEMNIFICATION REQUIREMENT

All policies and Certificates of Insurance of the Contractor shall contain the following clauses:

1. Essex County is named as an additional assured. Insurers shall have no right of recovery or subrogation against the County of Essex (including its agents and agencies), it being the intention of the parties that the insurance policies so effected shall protect both parties and be primary coverage for any and all losses covered by the above described insurance.

2. The clause "other insurance provisions" in a policy in which the County of Essex is named as an insured, shall not apply to the County of Essex.

3. The Insurance Companies issuing the policy or policies shall have no recourse against the County of Essex (including its agents or agencies) for payment of any premiums or for assessments under any form of policy.

4. Any and all deductibles in the above-described insurance policies shall be assumed by and at the risk of the Contractor.

The following indemnification agreement shall be, and is hereby, a provision of the Contract and shall be endorsed on the reverse side of all Certificates of Insurance:

The Contractor, person or firm agrees to protect, defend, indemnify and hold the County of Essex and its officers, employees and agents free and harmless from and against any and all losses, penalties, damages, settlements, costs, charges, professional fees or other expense or liabilities of every kind and character arising out of or relating to any and all claims, liens, demands obligations, actions, proceedings or causes of action of every kind and character in connection with or arising directly or indirectly out of this Agreement and/or the performance hereof. Without limiting the generality of the foregoing, and all such claims, etc., relating to personal injury, death, damage to property, defects in material or workmanship, actual or alleged infringement of any patent, trademark, copyright (or application for any thereof) or of any other tangible or intangible personal or property right, or any actual or alleged violation of any applicable statute, ordinance, administrative order, rule or regulation, or decree of any court shall be included in the indemnity hereunder. The contractor further agrees to investigate, handle, respond to, provide defense for and defend any such claims, etc. at his sole expense and agrees to bear all costs and expense related thereto, even if it (claims, etc.) is groundless, false or fraudulent.

14. Blasting - the Contractor shall comply with the requirements of the Penal Law, Section 1918, as amended, regarding blasting.

15. Wages - the Contractor shall pay a minimum wage which shall be equal to the hourly wage as scheduled by the New York State Department of Labor for the various classes of labor, such schedules being the prevailing rate in Essex County at the time of the receipt of bids. (See Attachment No. 1 - Prevailing Wage Rate). In addition, the following requirements of the Labor Law of the State of New York shall be complied with:

A. Latest amendments of Sections 220, 220-d and 220-e, 222 and 222-e.

16. Estimates and Payments - As the work progresses but not more than once a month and then on such days as he may fix, the Engineer will make an estimate in writing of the amount and value of the work performed and the materials and equipment incorporated in the work, such as in his opinion is just and fair. The first such estimate will be of the amount and value of work performed and material and equipment incorporated in the work since the Contractor began the work under the Contract. Every subsequent estimate except the final estimate will be of the amount incorporated in the work since the last preceding estimate was made. Except for the final estimate the amount of each such estimate less five percent (5%) retainage will be paid the Contractor within a reasonable time after the date of completion of such estimate by the Engineer. The retained percentage will be held until payment of the final estimate.

All estimates will be made for actual quantities of work performed and materials and equipment incorporated in the work as determined by the measurements of the Engineer, and this determination shall be accepted as final, conclusive and binding upon the Contractor. All estimates will be subject to correction in any succeeding estimate.

The Contractor shall furnish to the Engineer, prior to his making up any partial or final estimate, a copy of his and his sub-Contractor's weekly payrolls for each and every preceding payroll period. The payroll submitted shall be a certified true copy and shall contain full information including, but not limited to, the number of hours worked, rate, classification and total sum paid each employee charged to or working on the job.

With all except the first estimate, the Contractor shall furnish to the Engineer a sworn statement listing all unpaid bills and liabilities incurred under the Contract. Where there are any bills or liabilities in excess of money due under any estimate, the Engineer may withhold payment of the estimate pending a satisfactory proof of settlement or adjustment of any excess claims.

Subject to the prior approval of the Superintendent of Public Works, allowances for the value of certain materials or equipment stored on the construction site but not incorporated in the work may be used by the Engineer in making up estimates for partial payment, upon written request by the Contractor, subject to the following conditions.

- A. The material or equipment is stored and maintained on the construction site in first class condition in the manner directed by the Engineer.
- B. The material will not be used or the equipment will not be installed within forty-five (45) days from the date of the submission of the Contractor's request for partial payment.
- C. The Contractor has submitted certified copies of the manufacturer's or vendor's invoices or statements establishing the true purchase value of the material or equipment and evidence that the accounts for the claimed material or equipment have been paid in full.

Allowances for such materials or equipment shall not exceed ninety percent (90%) of the stored material or equipment, but the actual allowances incorporated in the estimates will be at the discretion of the Engineer.

Upon the completion of the required work as shown and specified in the Contract documents, should the final estimate of quantities show either an increase or decrease from the approximate estimates of quantities, then such variations will be computed at the unit price bid and the final estimate will be that arrived at by adding or deducting the respective amount from the gross sum bid.

The final estimate will be prepared after the work has been completed; tested and approved by the Engineer and after acceptance of the work has been given by the Superintendent of Public Works. No final estimate will be approved for payment unless and until the Contractor furnishes satisfactory proof that all bills and liabilities incurred under the Contract have been paid in full. Payments on the final estimate will not be made prior to the expiration of thirty-one (31) days from the date of acceptance of the work.

17. Contract Drawings - The Design Drawings, detailed in the **SPECIFICATIONS** show in general and/or in detail the work to be done under this Contract.

Upon request and after award and execution of the Contract, the successful Bidder will be issued for permanent possession a maximum of five (5) complete sets of the Contract Drawings and Specifications at no cost to him.

Additional sets beyond that number, requested by the Contractor, will be furnished to him by the Department, but at his expense.

18. Conditions of Work. Each Bidder must inform himself fully of the conditions relating to the work to be performed. Failure to do so will not relieve a successful Bidder of the obligation to furnish all material and labor necessary to carry out the provisions of the Contract documents and to complete the contemplated work for the consideration set forth in his bid.

At the time of the opening of bids, each Bidder will be presumed to have inspected the site and to have read and to be thoroughly familiar with the plans and Contract documents (including all addenda).

19. Addenda and Interpretation. No interpretation of the meaning of the plans, specifications or other Contract documents will be made to any Bidder orally. Every request for such interpretation should be in writing addressed to the Essex County Department of Public Works, 8053 US Route 9, Elizabethtown, NY 12932, and to be given consideration must be received at least five (5) days prior to the date fixed for opening the bids.

Any and all such interpretations and any supplemental instructions will be in the form of written addenda to the Specifications or plans which if issued will be mailed by Certified Mail with return receipt requested to all prospective Bidders (at the respective Addresses furnished for such purpose) not later than three (3) days prior to the date fixed for the opening of bids. Failure of any Bidder to receive any such addendum or interpretation or any other form, instrument or document shall not relieve any bidder from any obligation under his bid as submitted. All addenda so issued shall become part of the Contract.

20. Shown Quantities and Site Inspection. All bids shall be submitted upon the following express conditions which shall apply to and become a part of every bid received. The quantities shown on the Proposal Sheets opposite items of the work for which unit prices are to be bid are accepted by Bidders as being approximate estimated quantities. Bidders shall satisfy themselves by personal examination of the location of the proposed work and surroundings thereof, and by such other means, as they may prefer, as to the scope of the work and the accuracy of the approximate estimated quantities; and shall not at any time after submission of their bids dispute such approximate estimated quantities nor assert that there was any misunderstanding in regard to the quantity or kind of materials to be furnished, or work to be done.

The Contractor waives all claims of any nature due to a misunderstanding of the location, character, or other conditions surrounding the work or of the shown approximate estimated quantities of items of the work.

21. Increase or Decrease of Quantities: Elimination of Items: In entering into this Contract, the Contractor agrees that quantities shown on the proposal sheets opposite items of the work for which unit prices have been requested are approximate estimated quantities, and that during the progress of the work the County may find it advisable and shall have the right to omit portions of the work, and to increase or decrease the whole work; and that the County reserves the right to add to or take from the total amount of the work up to a limit of thirty percent (30%) of the total amount of the Contract based upon the executed Contract price for all the specified work.

The Contractor shall and will at no time make any claim for anticipated profit or loss of profits, because of any difference between the quantities of the various classes of work actually done, or of the materials actually furnished and the original specified scope of work and the shown approximate estimated quantities.

The aforesaid thirty percent (30%) pertains to the total amount of the Contract and not to any individual item. Individual items may be increased or decreased any amount or may be eliminated entirely if so ordered by the Engineer, excepting that the total amount of the Contract shall not be increased or decreased more than thirty percent (30%) except by mutual agreement between both parties thereto.

22. State and Local Sales Tax Exemption. The Contractor's attention is directed to the changes made in Section 1115 of the Tax Law of New York State by Chapters 513 and 514 of the Laws of 1974. In connection with capital improvement Contracts entered into on or after September 1, 1974, all tangible personal property which will become an integral component of a structure, building or real property of New York State, or any of its political subdivisions, including the County of Essex, is exempt from State and Local retail sales tax and compensating use tax.

In formulating their proposals, all Bidders shall exclude any dollar amounts for the payment of State and Local retail sales tax and compensating use tax. The successful Bidder shall be obligated to file the required Contractor Exempt Purchase Certificates, a sample of which is reproduced on the following pages of this Information for Bidders.

23. Engineering Charges. When the work embraced in the Contract is not completed on or before the date specified herein, engineering and inspection expenses incurred by the County of Essex upon the work from the completion date originally fixed in the Contract to the final date of completion of work may be charged to the Contractor and be deducted from the final monies due the Contractor. Consideration of any extra work or supplemental Contract work added to the original will be given due consideration by the County before assessing engineering and inspection charges against the Contractor. Such charges will be assessed, however in cases where in the opinion of the Engineer, the work has been unduly delayed by the Contractor.

24. Apprentices. The attention of all Bidders is directed to Section 220 (3-e) of the New York State Labor Law, which is hereby incorporated herein by reference, which requires, among other things, that "Apprentices will be permitted to work as such only when they are registered, individually, under a bona fide program registered with the New York State Department of Labor".

25. Affirmative Action Provision. During the performance of this Contract, the Contractor agrees that he will not discriminate against any employee or applicant for employment because of race, color, religion, sex, national origin, age or handicap. Such action shall include, but not be limited to the following: employment, upgrading, demotion or transfer; recruitment or recruitment advertising; layoffs or termination; rates of pay or other forms of compensation; and selection for training, including apprenticeship. Contractor agrees to include, or require the inclusion of the above provision in any subcontract made pursuant to its Contract with the County.

26. Certificate of Authority from the State of New York. Any corporation not incorporated under the Laws of New York State, must furnish a copy of its Certificate of Authority, from the New York State Secretary of State, to do business in the State of New York, in accordance with Article 13 of the New York State Business Corporation Law.

27. Licensing Requirements. On building alterations and new building construction Contracts, it shall be a requirement that all electrical and plumbing work be done under the direct supervision of a licensed electrician or plumber. For the purpose of this Contract, licensing shall mean licensure in a municipality in the geographic limits of Essex, Warren, Clinton, or Franklin Counties.

INDEX TO
GENERAL CLAUSES

<u>DESCRIPTION</u>	<u>PAGE NO.</u>
Article 1. Material and Workmanship	GC-2
Article 2. Definitions	GC-2
Article 3. Boundaries of Work	GC-3
Article 4. Proper Method of Work and Proper Materials	GC-3
Article 5. Control of Area	GC-3
Article 6. Permits, Fees, etc.	GC-3
Article 7. Traffic	GC-3
Article 8. Inspection	GC-3
Article 9. Stopping Work	GC-4
Article 10. Dimensions	GC-4
Article 11. Utilities and Service Lines	GC-4
Article 12. Sanitary Regulations	GC-4
Article 13. Representative Always Present	GC-4
Article 14. Work in Bad Weather	GC-4
Article 15. Protection of Work until Completion	GC-4
Article 16. Removal of Temporary Structures and Cleaning Up	GC-4
Article 17. Gross Loads Hauled on Highway	GC-5
Article 18. Repairs Caused by Damage Due to Contractor's Operations	GC-5
Article 19. Property Damage	GC-5
Article 20. Claims for Damages	GC-5
Article 21. Equivalent Quality	GC-5
Article 22. Payment	GC-5
Article 23. Extra Work: Increased Compensation Decreased Work: Credit to Owner	GC-6
Article 24. Disputed Work - Notice of Claim for Damages	GC-6
Article 25. Disqualification from Public Contracts of Persons who Refuse to Waive Immunity When Called to Testify Before a Grand Jury	GC-7
Article 26. Contractor's Report of Employment & Weekly Affidavit	GC-8
Article 27. Subletting	GC-8
Article 28. Assignment of Contract	GC-8
Article 29. Claims and Disputes	GC-8
Article 30. Resolution of Claims and Disputes	GC-10
Article 31. Delays	GC-10
Article 32. Overlapping Work Form - Contractor's Report of Employment and Weekly Affidavit	GC-10 GC-12

GENERAL CLAUSES

1. Material and Workmanship

It is the intent of these specifications to require first-class work constructed of new and best quality materials unless otherwise stated. For any unexpected features arising during the progress of the work and not fully covered herein, the specifications shall be interpreted by the Engineer to require first-class work and materials, and such interpretations shall be accepted by the Contractor. Upon award of the Contract the Contractor shall furnish in writing to the Engineer the sources of supply for concrete, and other materials, which he proposes to use in the work, and material shall not be furnished from other sources of supply except after approval by the Engineer.

2. Definitions

OWNER - The County of Essex

COUNTY - Party of the First part to the Contract as represented by the Superintendent of Public Works for the County of Essex.

SUPERINTENDENT - The head of the Department of Public Works of the County of Essex.

ENGINEER - The Superintendent of Public Works or his duly authorized representative.

INSPECTOR - The representative of the Engineer specially designated to supervise the work for which these specifications are intended.

PLANS - All official drawings or reproductions of drawings pertaining to the work or to any structure connected therewith.

SPECIFICATIONS - The body of directions, requirements, etc., contained in this present volume, together with all documents of the methods (or manner) of performing the work or to the quantities and quality. Specifications shall also include the Notice to Contractors, Instructions to Bidders, Bond, Proposal and Contract Agreement.

CONTRACT - Shall mean each of the various parts of these documents both as a whole or severally and except for titles, subtitles, headings and table of contents, shall include the Notice to Bidders, Information for Bidders, the Proposal, the Specifications, the Performance Bond, the Plans, the Contract Form, and all addenda and provisions required by law.

CONTRACTOR - Party of the second part to the contract acting directly or through his agents, sub-contractors, or employees, and who is responsible for all debts pertaining to and for the acceptable performance of the work for which he had contracted.

A.A.S.H.T.O. - American Association of State Highway and Transportation Officials

A.R.E.A. - American Railway Engineering Association

A.S.T.M. - American Society of Testing Materials

A.W.W.A. - American Water Works Association

N.E.C. - National Electrical Code

N.E.M.A. - National Electric Manufacturers Association

SURETY - The corporate body which is bound with and for the Contractor and which engages to be responsible for the faithful performance of the Contract and to indemnify the County against all claims for damages.

3. Boundaries of Work

The County will provide land or rights-of-way for the work specified in this Contract. Other contractors, employees or concessionaires of the County, may for all necessary purposes enter upon the work and premises used by the Contractor, and the Contractor shall give to other contractors and employees of the County all reasonable facilities and assistance for the completion of adjoining work.

4. Proper Method of Work and Proper Materials

The Engineer shall have the power in general to direct the order and sequence of the work, which will be such as to permit the entire work under this contract to be started and to proceed as rapidly as possible, and such as to bring the several parts of the work to a successful completion at about the same time. If at any time before the commencement or during the progress of the work the materials and appliances used or to be used appear to the Engineer as insufficient or improper for securing the quality of work required, or the required rate of progress, he may order the Contractor to increase efficiency or to improve their character, and the Contractor shall conform to such order; but the failure of the Engineer to demand any increase of such efficiency or improvement shall not release the Contractor from his obligation to secure the quality of work or the rate of progress specified.

5. Control of Area

Unloading of materials and parking of equipment shall be subject to the orders of the Engineer so far as he may find necessary for the protection and safety of the traveling public and the preservation of property.

6. Permits, Fees, Etc.

All necessary permits from County, State or other concerned Public Authorities shall be secured at the cost and expense of the Contractor. He shall also give all notices required by law, ordinance, or the rules and regulations of the concerned Public Bureaus or Departments, and also as a part of the Contract, comply without extra charge or compensation with all State Laws and all other Ordinances or Regulations that may be applicable to this work. Contractor, however, shall first notify the Owner before proceeding with the securing of all necessary permits and the giving of required notices.

7. Traffic

The Contractor shall be responsible for the Maintenance and Protection of traffic at all times until the date of completion and acceptance of his work. During the whole course of the work the Contractor shall so conduct his work and operations so as to interfere with traffic passing the work as little as possible and effect by every reasonable means the safety and comfort of pedestrians, vehicles and vehicle passengers passing the work.

8. Inspection

The Contractor shall at all times provide convenient access and safe and proper facilities for the inspection of all parts of the work. No work, except such shop work as may be so permitted, shall be done except in the presence of the Engineer or his assistants. No material of any kind shall be used upon the work until it has been inspected and accepted by the Engineer. All materials rejected shall be immediately removed from the work and not again offered for inspection. Any materials or workmanship found at any time to be defective shall be remedied at once, regardless of previous inspection. The inspection and supervision of the work by the Engineer is intended to aid the Contractor in supplying labor and materials in accordance with the specifications, but such inspection shall not operate to release the Contractor from any of his contract obligations.

9. Stopping Work

The Engineer may stop by written order any work or any part of the work under this contract if, in his opinion the methods employed or conditions are such that unsatisfactory work might result. When work is so stopped it shall not be resumed until the methods or conditions are revised to the satisfaction of the Engineer, which must be signified in writing.

10. Dimensions

Figured dimensions on the plans shall be given preference over scaled dimensions, but shall be checked by the Contractor before starting construction. Any errors, omissions or discrepancies shall be brought to the attention of the Engineer and his decision hereon shall be final.

11. Utilities and Service Lines

The Contractor is hereby warned that a reasonable opportunity is to be given the Municipalities and Public Service Corporations to alter and install pipes, conduits or other structures prior to placing of pavement. No guarantee is given that public utility structures and service lines herein shown are correctly located. Locations given are from the best available information

12. Sanitary Regulations

Necessary housing convenience for the use of the workmen for changing clothes and for protection during inclement weather shall be provided. Toilet accommodations, properly secluded from observation, shall also be erected and maintained by the Contractor in such manner and at such points as shall be approved, and their use shall be strictly enforced. The Contractor shall obey and enforce such other sanitary regulations and orders and shall take such precautions against infectious diseases as may be deemed necessary. The building of shanties or other structures for housing the men, tools, machinery or supplies will be permitted only at approved places, and the sanitary condition of the grounds in and at such shanties or other structures must be at all times maintained in a satisfactory manner.

13. Representative Always Present

The Contractor in case of his absence from the work shall have a competent representative or foreman present, who shall follow without delay, all instructions of the Engineer or his assistants in the prosecution and completion of the work in conformity with this Contract, and shall have full authority to supply labor and materials immediately.

14. Work in Bad Weather

During freezing, stormy or inclement weather, no work shall be done except such as can be done satisfactorily and in a manner to secure first-class construction throughout.

15. Protection of Work until Completion

The Contractor shall be responsible for the protection and maintenance of his work until the same has been accepted by the Owner and shall make good any damage to the work caused by floods, storms, settlements, accidents, or acts or the negligence of himself or his employees or others so that the complete work when turned over to the Owner will be in first-class condition and in accordance with the plans and specifications.

16. Removal of Temporary Structures and Cleaning Up

On or before the completion of the work the Contractor shall, without charge therefore, tear down and remove all buildings and other structures built by him for facilitating the carrying out of the work, and shall remove all rubbish of all kinds from the grounds which he has occupied, shall do any small amount of additional trimming and grading and shall leave the entire work and premises clean, neat and in good condition. The Contractor shall provide at his own expense suitable dumping places for such materials. When the necessity for protecting traffic ends, the Contractor shall remove all signs, lighting devices, barricades and temporary railing from the site of the work.

17. Gross Loads Hauled on Highway

The Contractor shall at no time during the construction of the Contract, haul gross loads exceeding the legal limit prescribed by the Highway Law over the highways of access to, or the highway included in this contract.

18. Repairs Caused by Damage Due to Contractor's Operations

In the event that damage is caused to structures, surfacing, pavement, shrubbery, trees, or to grassed areas through trucking operations, delivery of materials, the actual performance of the work, or other causes, the Contractor shall fully restore the same to their original condition at his own expense. In the event that damages to any one area are caused by more than one contractor, the Engineer will apportion the amount of repair work to be done by each contractor. The decision of the Engineer shall be final.

19. Property Damage

The Contractor shall not enter upon nor make use of any private property along the line of work except when written permission is secured from the Owner. In case of any damage or injury done along the line of work in consequence of any act or omission on the part of the Contractor, or any one in his employ, in carrying out the contract, the Contractor shall at his own expense restore the same or make repairs as are necessary in consequence thereof in a manner satisfactory to the Owner; provided, however, that the obligation thus assumed by the Contractor shall not inure directly or indirectly to the benefit of any insurer of physical damage to property or loss of use, rents or profits of property regardless of whether the insurer has actually paid the claim or made only a loan to its insured, nor to the latter if he shall waive or abandon any claim against his insurer or insurers.

20. Claims for Damages

No claims of any description for damages or delays caused by the work or negligence of other contractors will be allowed. Allowance will be made, however, for extension of the time of completion, provided, in the opinion of the Engineer, the delays of other contractors have actually delayed completion and further provided, that the Contractor has complied with those sections of the contract documents governing progress of the work, time of completion and extension of time.

21. Equivalent Quality

Wherever in the Contract Documents an article, material, apparatus, product or process is called for by trade name or catalog reference, or by the name of the patentee, manufacturer or dealer, it shall be the basis of the bid and shall be furnished under the Contract unless otherwise permitted by the Engineer. Should the Contractor desire to substitute other articles, materials, apparatus, products or processes, he shall apply to the Engineer in writing for approval of such substitution. With this application shall be furnished such information as required by the Engineer to demonstrate that the article, material, apparatus, product or process he wishes to use is the equal of that specified in quality, finish, design, efficiency and durability and has been elsewhere demonstrated to be equally serviceable for the purpose for which it is intended. The Contractor shall set forth the reasons for desiring to make the substitution and shall further state what difference, if any, will be made in the Contract price for such substitution should it be accepted; it being the intent hereunder that any savings shall accrue to the benefit of the County. If the Engineer shall reject any such desired substitution as not being the equal of that specifically named in the contract, or if he shall determine that the adjustment in price in favor of the County is insufficient, the Contractor shall immediately proceed to furnish the designated article, material, apparatus, product or process. Where two or more articles, materials, apparatus, products or processes are listed as acceptable by reference to trade name or otherwise, the choice of these will be optional to the Contractor.

22. Payment

No direct payment will be made for work done or materials furnished under the Information for Bidders, General Clauses and Special Clauses, except where expressly stated elsewhere, but compensation shall be deemed to be

included in the contract lump sum price for the total work and/or the contract unit prices for the various items of the work.

23. Extra Work: Increased Compensation

Decreased Work: Credit to the Owner

The Engineer may, at any time, by a written order, and without notice to the sureties, require the performance of extra work or require or approve changes in the work, or Decreased work ("work" to include but not be limited to specified methods of performing work) as he may deem necessary or desirable. The amount of compensation to be paid to the Contractor for any Extra Work, as so ordered, or credit to the Owner for such Decreased Work, as so ordered or approved, shall be determined as follows:

First: By such applicable unit prices, if any, as set forth in the Contract; or Second: If no such unit prices are so set forth, then by unit prices or by a lump sum, or sums, mutually agreed upon by the Engineer and the Contractor; or Third: If, in the opinion of the Engineer, the aforesaid unit prices, under "First" above, are not applicable, or if the two parties hereto cannot reach agreement as to new unit prices or a lump sum, or sums, under "Second" above, then by the actual net cost in money to the Contractor of the materials and of the wages of applied labor (including cost of supplements provided and premiums for Workmen's Compensation Insurance) required for such Extra Work, plus thirty percentum as compensation for all items of profit and costs or expenses including administration, overhead, superintendence, insurance (other than Workmen's Compensation Insurance) materials used in temporary structures, allowances made by the Contractor to subcontractors, including those made for overhead and profit, additional premiums upon the performance bond of the Contractor and the use of small tools and any and all other costs and expenses not enumerated above, plus such rental for plant and equipment (other than small tools) required and approved for such extra work. Where extra work is performed by a Subcontractor, the thirty percentum stipulated above shall be divided between the Contractor and the Subcontractor as per their contractual agreement, or if not defined herein, then as the Contractor sees fit.

Rental rates for any power-operated machinery, trucks or equipment, which it may be found necessary to use as in "Third" above, shall be negotiated between the Engineer and the Contractor. These rates shall be reasonable and shall be based on those prevailing in the area of the County where such work is to be done, and they shall be agreed upon in writing before the work is begun.

These rates shall include all repairs, fuel, lubricants, applicable taxes, insurance, depreciation, storage and all attachments complete, ready to operate, but excluding operators. Operators shall be paid as stated hereinabove for labor.

For equipment which is already on the project, the rental price shall start when ordered to work by the Engineer, and shall continue until ordered to discontinue by him.

No percentage shall be added to the amounts of equipment rental prices agreed upon, but the price agreed upon shall be the total compensation allowed for the use of such equipment.

The provisions hereof shall not affect the power of the Contractor to act in case of emergency.

24. Disputed Work - Notice of Claims for Damages

If the Contractor is of the opinion that any work required, necessitated, or ordered violates or conflicts with or is not required by the terms and provisions of this Contract, he must promptly, within five calendar days after being directed to perform such work, notify the Engineer, in writing, of his contentions with respect thereto and request a final determination thereon. If the Engineer determines that the work in question is contract and not extra work, or that the order complained of is proper, he will direct the Contractor in writing to proceed and the contractor shall

promptly comply. In order, however, to preserve his right to claim compensation for such work or damages resulting from such compliance, the Contractor must, within seven (7) calendar days after receiving notice of the Engineer's determination and direction, notify the Engineer, in writing that the work is being performed or that the determination and direction is being complied with, under protest. Failure of the contractor to so notify shall be deemed as a waiver of claim for extra compensation or damages therefore.

On or before the fifteenth day of the month succeeding that in which any such damage shall have been sustained, or alleged to have been sustained, the Contractor shall file with the Engineer an itemized statement setting forth in detail the hours, rates, amounts, etc., of the labor, materials, equipment and other costs of such damages incurred during the preceding month, and, unless such statement shall be made as thus required, his claim for compensation shall be forfeited and invalidated and he shall not be entitled to payment on account of any such damage.

In addition to the foregoing statements, the Contractor shall, upon notice from the Superintendent of Public Works, produce for examination by the duly appointed representative of the Superintendent of Public Works, all his books of accounts, bills, invoices, payrolls, subcontracts, time books, daily reports, bank deposit books, bank statements, checkbooks and cancelled checks, showing all of his acts and transactions in connection with or relating to or arising by reason of this contract, and submit himself, his agents, servants and employees for examination under oath by a duly appointed representative designated by the Superintendent of Public Works to investigate claims made against the County. Unless the aforesaid statements shall be made and filed within the time aforesaid and the aforesaid records submitted for examination and the Contractor, his agents, servants, and employees submit themselves for examination as aforesaid, the County shall be released from all claims arising under, relating to or by reason of this contract, except for the sums certified by the Engineer to be due under the provisions of this contract. It is further stipulated and agreed that no person has power to waive any of the foregoing provisions, and that in any action against the County to recover any sum in excess of the sums certified by the Engineer to be due under or by reason of this Contract, the Contractor must allege in his complaint and prove, at the trial, compliance with the provisions of this article.

Before final acceptance of the work by the County, all matters of dispute must be adjusted to the mutual satisfaction of the parties thereto. Determinations and decisions in case any questions shall arise, shall constitute a condition precedent to the right of the Contractor to receive the money therefore, until the matter in question has been adjusted.

25. Disqualification from Public Contracts of Persons who refuse to Waive Immunity

When Called to Testify Before a Grand Jury. It is understood and agreed by the Contractor that upon the refusal of the Contractor, or if the Contractor is a partnership or corporation, upon the refusal of a member, partner, director or officer of such partnership or corporation, when called before a grand jury to testify concerning any transaction or contract had with the State, any political subdivision thereof, a public authority or with any public department, agency or official of the State or any political subdivision thereof, or of a public authority, to sign a waiver of immunity against any future criminal prosecution or to answer any relevant question concerning such transaction or contract,

- (a) such person, and any firm, partnership or corporation of which he is a member, partner, director or officer, shall be disqualified from thereafter selling to or submitting bids to or receiving awards from or entering into any contract with the State, the County of Essex, or any public department or official thereof, for goods, work or services, for a period of five (5) years after such refusal to sign a waiver of immunity; and
- (b) any and all contracts made with the State, the County of Essex or any public department, agency or official thereof, since July 1, 1959 by such person and by any firm, partnership or corporation of which he is a member, partner, director or officer, may be cancelled or terminated by the State, or by the

County of Essex, without incurring any penalty or owing pursuant to said transaction or contract prior to the cancellation and termination, shall be paid.

26. Contractor's Report of Employment and Weekly Affidavit

Each week the Contractor shall furnish to the Superintendent of Public Works a report of employment and affidavit in the form as shown within.

27. Subletting

As soon as practicable after execution of the contract, the successful bidder shall submit to the County for approval, a list with the names and addresses of the subcontractors to whom he is proposing to sublet parts of the work, and statements of the work they are to perform. He shall also submit additional information regarding their qualifications as may be later requested by the County. No part of the work may be sublet until after the Contractor has received the County's approval.

The Contractor shall be fully responsible for all acts and omissions of his subcontractors and persons directly or indirectly employed by them, and the County's approval to sublet parts of the work will in no way relieve the Contractor of any of his obligations under the Contract. All dealings of the Engineer with the subcontractors shall be through the Contractor, subcontractors being recognized by the County only as employees of the Contractor.

The Contractor shall insert appropriate clauses in all subcontracts to bind the subcontractors to the Contractor by all applicable provisions of the contract documents executed between the Contractor and the County, but this shall not be construed as creating any contractual relationship between subcontractors and the County. Prior to approval of the subcontractors, the County has the right to review and recommend changes in the subcontracts.

The County may designate the percentage and the specific parts of the total work that can be sublet by the Contractor, and if this designation has been made, it will be described in the Special Clauses.

28. Assignment of Contract

The Contractor shall not assign, transfer, convey or otherwise dispose of the Contract or any part of it or any monies due and payable under the Contract, without prior written approval of the County. If such approvals are granted by the County, they shall in no way relieve the Contractor from any of his obligations under the terms of this contract. All documents assigning the Contract or any part of it or any monies due and payable under the Contract shall under the Contract shall contain a clause stating that all monies to be paid the assignee in accordance with the terms of the Contractor's contract with the County, are subject to a prior lien for services rendered or materials and equipment supplying such materials and equipment.

29. Claims and Disputes

Definition. A Claim is a demand or assertion by one of the parties seeking, as a matter of right, adjustment or interpretation of Contract terms, payment of money, extension of time or other relief with respect to the terms of the contract. The term "Claim" also includes other disputes and matters in question between the County and Contractor arising out of or relating to the Contract. Claims must be made by written notice. The responsibility to substantiate Claims shall rest with the party making the Claim. The written notice of claim must be accompanied by full documentation and proof to substantiate the claim.

Decision of Essex County, its Engineer or Construction Manager. Claims shall be referred initially to the County or its Engineer or Construction Manager for action as provided below. A decision by the County or its Engineer or Construction Manager, shall be required as a condition precedent to litigation of a Claim between Essex County and Contractor as to all such matters arising prior to the date final payment is due, regardless of (1) whether such matters relate to execution and progress of the Work or (2) the extent to which the Work has been completed. The decision

by the County or Construction Manager in response to a Claim shall not be a condition precedent to arbitration or litigation in the event (1) **the position of the County** _____ or Construction Manager is vacant, (2) the County or Construction Manager has not received evidence or has failed to render a decision within agreed time limits, (3) the County or its Engineer or Construction Manager has failed to take action required within 15 days after the Claim is made, (4) 45 days has passed after the Claim has been referred to the County or its Engineer or Construction Manager or (5) the Claim relates to a mechanic's lien.

Time Limits on Claims. Claims by either party must be made with 15 days after occurrence of the event giving rise to such Claim or within 15 days after the claimant first recognizes the condition giving rise to the Claim, whichever is later. Claims must be made by written notice. An additional Claim made after the initial Claim has been implemented by Change Order will not be considered unless submitted in a timely manner.

Continuing Contract Performance. Pending final resolution of a Claim, unless otherwise agreed in writing Contractor shall proceed diligently with performance of the Contract and Essex County shall continue to make payments in accordance with the Contract Documents.

Waiver of Claims: Final Payment. The making of final payment shall constitute a waiver of Claims by Essex County except those arising from:

- (a) Liens, Claims, security interest or encumbrances arising out of the Contract and unsettled;
- (b) Failure of the Work to comply with the requirements of the Contracts Documents; or
- (c) Terms of special warranties required by the Contract Documents.

Claims for Concealed or Unknown Conditions. If conditions are encountered at the site which are (1) subsurface or otherwise concealed physical conditions which differ materially from those indicated in the Contract Documents or (2) unknown physical conditions of an unusual nature, which differ materially from those ordinarily found to exist and generally recognized as inherent in construction activities of the character provided for in the Contract documents, then notice by the observing party shall be given to the other party promptly before conditions are disturbed and in no event later than 15 days after first observance of the conditions. The County or its Engineer or Construction Manager will promptly investigate such conditions and, if they differ materially and cause an increase or decrease in Contractor's cost of, or time required for, performance of any part of the Work, will recommend an equitable adjustment in the Contract Sum or Contract Time, or both. If the County or its Engineer or Construction Manager determines that the conditions at the site are not materially different from those indicated in the Contract Documents and that no change in the terms of the Contract is justified, the County shall so notify the County and Contractor in writing, stating the reasons. Claims by either party in opposition to such determination must be made within 15 days after the County has given notice of the decision. If the County and Contractor cannot agree on an adjustment in the Contract Sum or Contract Time, the adjustment shall be referred to the County or its Engineer or Construction Manager for initial determination.

Claim for Additional Cost. If Contractor wishes to make Claim for an increase in the Contract Sum, written notice as provided herein shall be given before proceeding to execute the work. If Contractor believes additional cost is involved for reasons including but not limited to (1) a written interpretation from the County or its Engineer or Construction Manager, (2) an order by the County to stop the Work where Contractor was not at fault, (3) a written order for a minor change in the Work issued by the County or its Engineer or Construction Manager, (4) failure of payment by Essex County, (5) termination of the contract by Essex County, (6) Essex County's suspension or (7) other reasonable grounds, Claim shall be filed and evaluated in accordance with the procedure established herein and under this Section 29 and Section 30 of these Supplementary Conditions.

30. Resolution of Claims and Disputes

The County or Construction Manager will review Claims and take one or more of the following preliminary actions within fifteen (15) days of receipt of a Claim: (1) request additional supporting data from the claimant, (2) submit a schedule to the parties indicating when the County or Construction Manager expects to take action, (3) reject the Claim in whole or in part, stating reasons for rejection, (4) recommend approval of the Claim by the other party or (5) suggest a compromise. The County or Construction Manager may also, but is not obligated to, notify the surety, if any, of the nature and amount of the Claim.

If a Claim has been resolved, the County or Construction Manager will prepare or obtain appropriate documentation.

If a Claim has not been resolved, the party making the Claim shall, within ten days after the County or Construction Manager's preliminary response, take one or more of the following actions: (1) submit additional supporting data requested by the County or Construction Manager, (2) modify the initial Claim or (3) notify the County or Construction Manager that the initial Claim stands.

If a Claim has not been resolved after consideration of the foregoing and of further evidence presented by the parties or requested by the County or Construction Manager, the County or Construction Manager will notify the parties in writing that the County or Construction Manager's decision will be made within ten (10) days, which decision shall be final and binding on the parties but subject to arbitration. Upon expiration of such time period, the County or Construction Manager will render to the parties the County or Construction Manager's written decision relative to the Claim, including any change in the Contract Sum or Contract Time or both. If there is a surety and there appears to be a possibility of a Contractor's default, the County or Construction Manager may, but is not obligated to, notify the surety and request the surety's assistance in resolving the controversy.

The parties expressly agree that any and all controversies and claims arising out this contract will not be referred to arbitration but will be referred and brought in a Court of competent jurisdiction within Essex County, New York.

31. Delays

Essex County shall not be liable to the Contractor or any subcontractors for claims or damages of any nature caused by or rising out of delays. The sole remedy against Essex County for delays shall be the allowance of additional time for completion of the Work, the amount of which shall be subject to the claims procedure set forth herein. Except to the extent, if any, expressly prohibited by law, Contractor expressly agrees not to make and hereby waives any claim for damages for delay, including, but not limited to those resulting from increased labor or material costs, directions given or not given by Essex County, including scheduling of the work, or an account of any delay, or on account of any delay, obstruction, or hindrance for any cause whatsoever by Essex County, or its agents or any other Contractor on the project, whether or not foreseeable or anticipated. CONTRACTOR AGREES THAT ITS SOLE RIGHT AND REMEDY THEREFORE SHALL BE AN EXTENSION OF TIME, IF APPROPRIATE. IT IS EMPHASIZED THAT NO MONETARY RECOVERY MAY BE OBTAINED BY CONTRACTOR FOR ANY DELAY AGAINST ESSEX COUNTY, CONSTRUCTION MANAGER, OR ITS ENGINEER BASED ON ANY REASON AND THAT CONTRACTOR'S SOLE REMEDY, IF APPROPRIATE, IS ADDITIONAL TIME.

32. Overlapping Work

The Contractor shall take notice that because of work on other contracts within and adjacent to the contract limits he may not have exclusive occupancy of the territory within or adjacent to the contract limits, and that during the life of this contract the owners and operators of Public Utilities may make changes in their facilities. The said changes may be made by utility employees or by contract within or adjacent to the contract limits and may be both temporary and permanent. The Contractor shall cooperate with other Contractors and owners of various utilities and shall coordinate and arrange the sequence of his work to conform with the progressive operations of work already or to be put under contract. Cooperation with Contractors already or to be engaged upon the site is essential to properly coordinate the construction efforts of all Contractors, Utility owners and Sub-contractors engaged in work within

and adjacent to the contract limits.

The Contractor shall coordinate the work of his various Subcontractors. Their respective operations shall be arranged and conducted so that delays are avoided. Where the work of the Contractor or Subcontractors overlaps or dovetails with that of other Contractors, materials shall be delivered and operations conducted so as to carry on the work continuously in an efficient and workmanlike manner. Delays or oversights on the part of the Contractor or Subcontractors or Utility Owners in performing their work in the proper manner thereby causing cutting, removing and replacing work already in place, shall not be the basis for a claim for extra compensation.

In the event of interference between operations of Utility Owners and other Contractors, the Engineer shall be the sole judge of the rights of each Contractor and the sequence of work necessary to expedite the completion of the entire project, and in all cases his decision shall be final. The Contractor agrees that he has included in his unit prices bid for the various items of the Contract the possible additional cost of performing the work under this contract because he may not have a clear site for his work and because of possible interference of roadway use, other Contractors and necessary utility work, and the necessity or desirability of opening certain sections of pavement to traffic before the entire work is completed.

Delays in availability of any part of the site or any delays due to interference between the several Contractors and the Utility Owners shall be compensated for by the Engineer solely through granting an extension of time in which to complete the work of the contract without assessment of Engineering charges. The Contractor in submitting his bid hereby agrees that he shall make no other claim against the County for any damages due to such delays or interference.

CONTRACTOR'S REPORT OF EMPLOYMENT AND WEEKLY AFFIDAVIT

County of Essex

Department of Public Works

Contract No. _____ Report No. _____ Weeks Ending _____

Title of Contract and Location _____

Contractor or Subcontractor _____

Address _____

I, _____
(Name of signatory person and title)

being duly sworn, to depose and say, that I pay or supervise the payment of the persons employed by

(Contractor or Subcontractor)

on the above referenced contract work; that during the payroll period commencing on the ____ day of _____
____ 20__ and ending on the ____ day of _____, 20__, all persons employed by me on the contract
work have been paid the full weekly wages earned; that no rebates have been made or will be made either directly or
indirectly to or on behalf of said _____, other than those deductions which are
permissible or required by the various Federal, State or local statutes and ordinances; and that the following
summary of wages paid is true and accurate:

	<u>During the Week</u>	<u>Total to Date</u>
Number of names on payroll		
Hours works		
Total wages earned		

By _____
(Signature and Title)

State of _____) ss.
County of _____)

Sworn to before me this ____ day of _____ 20__

Notary Public

The above summary of wages paid is true and accurate as to facts and extensions, to the best of my knowledge and belief.

(DATE)

(Signature & Title of Essex County Public Works Engineer)

INDEX TO
STANDARD SPECIAL CLAUSES
ROAD AND BRIDGE CONSTRUCTION CONTRACTS

<u>DESCRIPTION</u>	<u>PAGE NO.</u>
Article 1. Intent	SCRB-2
Article 2. Contract Terms	SCRB-2
Article 3. Tonnage Payments	SCRB-2
Article 4. Pre-Construction Conference	SCRB-2
Article 5. Preservation of Natural Features	SCRB-2
Article 6. NYS DEC Municipal General Permit	SCRB-3
Article 7. Prevention of Dust Hazard	SCRB-3
Article 8. Use of Explosives	SCRB-3
Article 9. Construction Near Pipes Conveying Combustible Gas	SCRB-4
Article 10. Notice of Utility Owners	SCRB-4
Article 11. Protection of Utilities and Structures	SCRB-4
Article 12. Test Pits	SCRB-4
Article 13. Protection of Pavement	SCRB-4
Article 14. Protection of Structures from Bituminous Materials	SCRB-4
Article 15. Salvable Materials	SCRB-5
Article 16. Filling and Backfilling at Structures, Culverts and Pipes	SCRB-5
Article 17. Areas Inaccessible to Roller	SCRB-5
Article 18. Pipes and Culverts in Fill Areas	SCRB-5
Article 19. Delivery of Materials	SCRB-5
Article 20. Asphalt Concrete Payment	SCRB-5
Article 21. Portland Cement Concrete	SCRB-5
Article 22. Cleaning of Catch Basins and Manholes	SCRB-5
Article 23. Noisy Manhole Covers	SCRB-6
Article 24. Guarantee of the Work Under the Contract	SCRB-6
Article 25. Contract Work by General Contractor	SCRB-6

APPENDIX A – NYS DEC Municipal General Permit

STANDARD SPECIAL CLAUSES
ROAD AND BRIDGE CONSTRUCTION CONTRACTS

1. Intent.

The Special Clauses modify or supplement the Information to Bidders, the General Clauses and the Standard Itemized Specifications and govern where there is conflict with those documents.

2. Contract Items.

All Materials of Construction, General Construction Items and Item Specifications, and Roadside Development Payment Items and Item Specifications not prefixed with the letter "E" shall be as specified in Section 200 thru 700 of the State of New York, Department of Transportation Design and Construction Division Standard Specifications of January 2, 2008 as amended to date, hereafter referred to as the "New York State Department of Transportation Specifications." In utilizing the State Department of Transportation Specifications, the following substitutions in the text shall be made:

- a. for State, substitute County of Essex
- b. for Department or Division, substitute Essex County Department of Public Works
- c. for Commissioner substitute Essex County Superintendent of Public Works
- d. for Executive Deputy Commissioner substitute Deputy Superintendent of Public Works
- e. for Chief Engineer, Deputy Chief Engineer, District Engineer, Engineer, or Engineer in Charge, substitute Engineer
- f. for Comptroller, substitute County Treasurer of Essex County Copies of the State publication are available for reference purposes in the offices of the Engineering Division, Essex County Department of Public Works, 8053 US Route 9, Elizabethtown, NY 12932 (office location, Route 9, Town of Lewis). They may be purchased from Accounting and Fiscal Service Bureau, D.O.T., State Office Campus, 1120 Washington Avenue, Albany, NY, 12232.

3. Tonnage Payments.

Each delivery to the work site of materials for construction for which payment is specified to be made on a tonnage basis, a ton being defined as 2000 pounds, shall be accompanied by a copy of a certified weigh-master's certificate or tape from an approved measuring computer, and that copy shall be given over into the permanent possession of the Engineer.

4. Pre-Construction Conference.

The Contractor shall not commence any work under the contract prior to a pre-construction conference between the Contractor, the County's representatives and other concerned governmental and utility company representatives. At this conference all special requirements of the work, the scheduling of the work and details for the proper maintenance and protection of traffic during the work will be fully explained and discussed.

The Contractor shall submit a proposed schedule for maintaining, protecting, and regulating traffic, showing chronologically and in detail the sequence and methods that will be followed. In the event the Contractor desires to use traffic control devices other than those specified, he shall submit his request with samples or detailed sketches and descriptions of the proposed devices, for approval by the County.

5. Preservation of Natural Features.

Essex County lies entirely within the boundary of the Adirondack Park and, therefore, the Contractor shall exercise extraordinary care to preserve and protect the natural features of all public and private property on or adjacent to the work site which will not be directly affected by the required construction. Before commencing work under the contract, the Contractor shall secure the Engineer's approval of proposed locations for temporary access roads not specified, storage areas for his equipment and materials, and parking areas for his/her own vehicles and those of his/hers workers. Thereafter, unless otherwise approved by the Engineer, the Contractor shall restrict all such activities to these locations. Before completion of the contract work, the Contractor shall restore at his/her own expense to their original condition or better, all temporary access, storage or parking areas

and all other areas on or adjacent to the work site not directly affected by the required construction which have been disturbed in any way by the Contractor's operations.

The Contractor shall be responsible for the preservation and protection of all parts of existing trees within and bordering on the contract limits. As may be required at his own expense the Contractor shall protect the trunks of trees against injury by the proper use of burlap padding, boards or other protective devices approved by the Engineer.

6. Protection of Waters and Environmental Conservation Law Compliance

The County of Essex shall obtain a Protection of Waters Permit or a Municipal General Permit from NYSDEC. The contractor shall be provided with a copy of the permit. The Contractor shall be responsible for complying with all the Protection of Waters Permit and Municipal General Permit condition. Municipal Permit conditions are provided in Appendix "A" of this document.

7. Prevention of Dust Hazard.

In accordance with the New York State Labor Law, Section 22a, in the event a silica or other harmful dust hazard is created due to construction operations under the contract, the Contractor shall install, maintain and keep in effective operation the appliances and methods for the elimination of such silica dust or other harmful dust as have been recommended and approved by the State and local authorities.

8. Use of Explosives.

Explosives for blasting shall be stored, handled and used in accordance with the laws, ordinances and regulations of the State of New York and the local municipalities involved, and following the safety recommendations contained in the latest edition of the "Manual of Accident Prevention in Construction" published by the Associated General Contractors of America, Inc., and the latest editions of the pamphlets published by the Institute of Makers of Explosives entitled, "Do's and Don'ts - Instructions and Warnings in Using, Transporting, Handling and Storing Explosives" and "Safety in the Handling and Use of Explosives."

The Contractor shall limit all blasting operations to a minimum and shall notify the Engineer and local municipal authorities at least seventy-two hours in advance of all such operations. No blasting of any kind shall be done during other than normal working hours on normal working days, unless permission is first secured from the Engineer and from local municipal authorities. The Contractor shall protect the traveling public from all damage to person and property and shall be responsible for damage to pipe lines, conduits, cables and any other surface or subsurface lines or structures that may be encountered, and for damage caused by blast shocks or debris.

The Contractor shall utilize only thoroughly trained and experienced men in all blasting operations, and blasting crews shall be held to the minimum consistent with efficient operation. They shall be thoroughly familiar with all recommended safety practices and shall be adequately supervised to insure that they adhere to those practices. No person under eighteen years of age shall be permitted to handle, use or be near explosives.

In accordance with the New York State Penal Law, Section 1918 as amended, the Contractor or his subcontractor shall not discharge explosives in the ground unless written notice is first given seventy-two hours in advance to the person, corporation or municipality engaged in the distribution of combustible gas in the area. He shall further ascertain if there are any gas lines within a radius of two hundred feet from the point of discharge which are being maintained by a person, corporation or municipality other than the person, corporation or municipality servicing the territory. If there are, he shall give written notice seventy-two hours in advance to those parties. Thereafter the work shall be performed in such manner as to avoid damages to any pipe conveying combustible gas.

In any emergency, if explosives must be discharged in order to protect persons from immediate and substantial

danger of death or serious personal injury, the seventy-two hour notice requirements of this article will be waived, provided the Engineer, the concerned persons, corporations or municipalities are notified as soon as reasonably possible before any such discharge is undertaken.

9. Construction Near Pipes Conveying Combustible Gas.

In accordance with the New York State Penal Law, Section 1918 as amended, the Contractor shall not excavate any existing street, highway or public place unless written notice shall have been given at least seventy-two hours in advance to the person, corporation or municipality engaged in the distribution of gas in such territory. He shall further ascertain whether there is within one hundred feet in such street, highway or public place any other person, corporation or municipality conveying combustible gas in pipe, and if there is such pipe, he shall also give similar notice to such person, corporation or municipality.

10. Notices to Utility Owners.

At least forty-eight hours before breaking ground for construction, the Contractor shall give written notice to all concerned utility owners that valve boxes, curb boxes, manholes and other similar structures must be adjusted to the finished surfaces of roadway, shoulder or sidewalk areas, or that pipes, conduits, poles or other structures must be altered, removed or relocated. Thereafter the Contractor shall give a reasonable opportunity to the owner of the utility or structure to have the work done. All work adjusting structures or altering, removing, relocating or installing pipes, conduits, poles or other structures will be done at the expense of the owners of the utility or structure, utilizing their own facilities if they so choose, or by utilizing the forces of the Contractor under separate contract.

11. Protection of Utilities and Structures.

The Contractor shall be responsible for the preservation of all public and private underground and surface utilities and structures at or adjacent to the site of construction, insofar as they may be endangered by his operations. This shall hold true whether or not they are shown on the contract drawings. If they are shown on the drawings, their locations are not guaranteed by the County even though the information will be from the best available sources, and in any event, others not shown may be encountered in the field. The Contractor shall give ample and reasonable notice to all private, corporate, or municipal owners before work is done near their utility or structure, shall properly protect all utilities and structures he encounters, shall at his own expense repair or replace any that he damages, and shall constantly proceed with caution to prevent undue interruptions to utility services.

12. Test Pits.

Test pits shall be excavated by the Contractor at such locations as may be designated by the Engineer for the purpose of locating underground structures and pipes or to determine subsurface conditions. Test pits shall be backfilled at such time as directed by the Engineer. Payment for this work will be made under applicable excavation payment items that may be in the contract; otherwise payment will be made under Item E-800-Miscellaneous Additional Work.

13. Protection of Pavement.

No equipment other than equipment with rubber tires will be allowed on any existing or new pavement within the limits of the Contract, unless the pavement has been first protected by planking or other means approved by the Engineer.

14. Protection of Structures from Bituminous Materials.

Before applying any bituminous materials, the Contractor shall protect as may be necessary all inlets, catch basins, manholes, vaults, water valve boxes, walls, curbs, gutters and other similar structures to prevent their defacement by such materials. Structures shall be completely covered or treated to prevent bituminous materials from entering their covers, gratings or crevices, or to prevent their concealment. After the application of the bituminous materials has been completed, the Contractor shall inspect all structures within the area of

such construction activities and remove all remaining bituminous defacements caused by his operations.

15. Salvable Materials

All existing construction materials such as manhole and catch basin frames and casting, pipe, curbs, signs, guide railing and other similar salvable materials encountered in the work and owned by the County, a political subdivision of the County or third parties, which the Engineer directs to be salvaged but not reused in the work, shall be removed and stored by the Contractor at areas on or adjacent to the work site. The Contractor shall then notify the respective owners in writing that the salvaged material is awaiting their disposition. If the material is not claimed or removed by the owners within a reasonable time after written notices have been given, as determined by the Engineer, the materials shall then become the property of the Contractor and shall be removed by him before completion of the work under the Contract.

Similar construction material which is removed by the Contractor and which the Engineer orders not to be salvaged shall become the property of the Contractor and shall be immediately removed by him from the site of the work.

16. Filling and Backfilling at Structures, Culverts & Pipes.

All filling and backfilling at structures, culverts and pipes shall be done in accordance with the provisions of subsection 203-3.15 of the General Specifications of the New York State Department of Transportation Specifications, except as follows:

Backfill shall be placed over pipe to a minimum height of twelve inches.

17. Areas Inaccessible to Roller.

Compaction of subgrade and base courses where widths restrict the use of a standard ten-ton roller shall be accomplished with a trench roller or a vibrating compactor, in accordance with the directions of the Engineer.

18. Pipes and Culverts in Fill Areas.

Where pipes or culverts are to be placed in fill areas, the Contractor shall first place and compact the fill to a plane one foot above the design elevation of the top of the pipe and the trench thereafter excavated.

19. Delivery of Materials.

The Contractor shall make his own arrangements for the receipt of materials delivered to the construction site. No representative of the County will accept any materials ordered by the Contractor.

20. Asphalt Concrete Pavement.

- a. In order to insure the uniform appearance of finished pavement, aggregate from only one stone quarry shall be used throughout the work.
- b. Prior to the placement of asphalt concrete pavement, the contact surfaces of all structures within or adjacent to the area of the new pavement shall be
- c. painted with the same bituminous material as used in the pavement mix. Payment for the forgoing work shall be deemed to be included in the unit price the Contractor has bid for the appropriate asphalt concrete payment item.

21. Portland Cement Concrete.

It is intended that all concrete placed under the Contract shall be air-entraining concrete. The type of Portland cement to be used shall be Type 2 with an approved air-entraining agent as specified in Section 701-01 Portland cement and Section 711-08 Admixtures of the New York State Department of Transportation Specification. The amount of air-entrainment shall be as required in Table 501.4 of the same specifications.

22. Cleaning of Catch Basins and Manholes.

After completion of all other work under the contract, the Contractor shall thoroughly clean out all catch basins

and manholes that have been built, altered or adjusted as part of the work of the contract, and shall remove from all other catch basins and manholes within the limits of the contract, all materials and debris deposited therein as the direct result of his operations under the Contract. Payment for all the foregoing work shall be deemed to be included in the unit prices the Contractor has bid for the appropriate payment item for building, altering or adjusting catch basins and manholes.

23. Noisy Manhole Covers.

After the work of resurfacing old pavement or the placement of new pavement has been completed, the Contractor shall check all structures within the limits of the contract for the existence of noisy manhole covers. All such manhole covers shall then be treated with an approved anti-rattling compound, in accordance with the directions of the Engineer. Payment for all the foregoing work shall be deemed to be included in the unit prices the Contractor has bid for the appropriate payment item for building, altering or adjusting catch basins and manholes.

24. Guarantee of the Work Under the Contract.

Unless otherwise stated in other parts of the specifications, all work performed under the contract shall be guaranteed by the Contractor against all defects resulting from the use of inferior materials, equipment or workmanship, for a period of one year from the date of final completion and acceptance of the work, or from the date the County take possession and make full use of the constructed facility.

25. Contract Work by General Contractor.

Contract work amounting to not less than 50 percent of the executed contract price shall be performed by the Contractor's own organization which shall be construed to include only workman directly employed and paid by the Contractor, and equipment owned or rented by the Contractor, such equipment being furnished with or without operators.

The only exception to the foregoing requirement shall relate to "Specialty Items" as designated by the County in these specifications or during the course of the actual contract construction work. "Specialty Items" shall be construed to be limited to contract work requiring highly specialized knowledge, craftsmanship or equipment not ordinarily available in the contracting organizations qualified to bid on this contract as a whole, and in general, shall be limited to minor components of the total contract. Such "Specialty Items" of the contract work may be sublet by the Contractor, but only after he has solicited permission to do so from the County and the County has granted such permission and has approved the Contractor's proposed subcontractor. The total sum of all County approved "Specialty Item" subcontracts as negotiated directly by the Contractor will be deducted from the contract price as executed between the Contractor and the County, before the County computes the final dollar amount of contract work that the Contractor must and shall perform with his own organization.



NEW YORK STATE DEPARTMENT OF ENVIRONMENTAL CONSERVATION
General Permit Number GP-5-12-001

PERMIT
Under the Environmental Conservation Law (ECL)

GENERAL PERMIT GP-5-12-001
Municipal

Permittee and Facility Information

Permit Issued To:

Facility:

Applicable DEC Region(s): 5

General Permit Authorized Activity: Projects designed and constructed for County and Municipal offices and are located in

- (a) navigable waters of the state; and/or
- (b) non-navigable waters of the state classified AA, AA(T), A, A(T), B, B(T) and C(T); and/or
- (c) regulated NYS DEC Freshwater Wetlands (FWW) and their 100 foot Adjacent Areas (AA) not within the Adirondack Park boundary.

All projects are limited to the following thresholds:

1. Construction or placement of a single-span bridge with no central supports, including associated bank and substructure erosion protection that involves stream bed/bank disturbance which totals less than one hundred (100) lineal feet.
2. New installation, replacement, repair or maintenance of a single arch, box, elliptical or round culvert and associated headwall protection that involves stream bed/bank disturbance which totals less than seventy (70) lineal feet, provided the replacement or repair does not consist of slip-lining.
3. The implementation of instream stabilization, habitat or feature techniques.
4. The implementation, construction or placement of non-vertical erosion protection structures, not in conjunction with any other activity listed herein, that involves stream bed/bank disturbance which totals less than one hundred (100) lineal feet.
5. Restoration, maintenance, replacement, substantial reconstruction, modification or expansion of existing functional structures other than culverts, or facilities located in (a) navigable waters, (b) protected streams and (c) FWWs and AAs, including but not limited to utility lines, bridges, roads, highways, railroad beds or paved areas; provided the activity involves less than one-quarter (1/4) acre of new disturbance in the regulated FWW and AA.
6. Installation of dry hydrants for fire protection purposes.



Permit Authorizations

Excavation & Fill in Navigable Waters - Under Article 15, Title 5

Effective Date: 03/12/2012 Expiration Date: 03/11/2022

Freshwater Wetlands - Under Article 24

Effective Date: 03/12/2012 Expiration Date: 03/11/2022

Stream Disturbance - Under Article 15, Title 5

Effective Date: 03/12/2012 Expiration Date: 03/11/2022

Water Quality Certification - Under Section 401 - Clean Water Act

Effective Date: 03/12/2012 Expiration Date: 03/11/2022

NYSDEC Approval

By acceptance of this permit, the permittee agrees that the permit is contingent upon strict compliance with the ECL, all applicable regulations, and all conditions included as part of this permit.

General Permit Authorized by

Permit Administrator: MARC S MIGLIORE , Deputy Regional Permit Administrator

Address: REGION 5 WARRENSBURG SUB-OFFICE
232 GOLF COURSE RD
WARRENSBURG, NY 12885

Authorized Signature: _____

Date: 03/12/2012

Permit Components

NATURAL RESOURCE PERMIT CONDITIONS

WATER QUALITY CERTIFICATION SPECIFIC CONDITION

GENERAL CONDITIONS, APPLY TO ALL AUTHORIZED PERMITS

NOTIFICATION OF OTHER PERMITTEE OBLIGATIONS

NATURAL RESOURCE PERMIT CONDITIONS - Apply to the Following Permits: WATER QUALITY CERTIFICATION; STREAM DISTURBANCE; FRESHWATER WETLANDS; EXCAVATION & FILL IN NAVIGABLE WATERS



REPORTING AND RECORD KEEPING

- 1. Other Agency Approvals** This Municipal General Permit does not eliminate the need to obtain approvals from other local, state or federal agencies such as the Adirondack Park Agency (APA) for projects located within the Adirondack Park, the Lake George Park Commission (LGPC) for projects located in Lake George Park, the Hudson River-Black River Regulating District (HRBRRD) for projects located on Great Sacandaga Lake or the U.S. Army Corps of Engineers (USACE) for projects which are located in Federal waters or wetlands.
- 2. Floodplain Regulations** The project must meet all local and federal floodplain regulations and, if applicable, a written approval from the floodplain administrator must be kept on file.
- 3. Project Segmentation Prohibited** Projects for this General Permit (GP) shall be complete projects, not a part of a larger project that exceeds the thresholds of this GP's Authorized Activity.
- 4. Authorization to Commence Work** The permittee shall notify the Regional Permit Administrator at least 3 business days prior to the commencement of work that work will begin on the project. Notification shall be made by completing and faxing, e-mailing or mailing the Authorization Form to the Regional Permit Administrator at the location indicated on the form. Should the Department not contact the permittee with objections to the proposal within the 3 business after receiving the Authorization Form, there shall be no objection to the activity or activities authorized, and the Authorization Form will be date-stamped and returned, documenting receipt by the Regional Permit Administrator.
- 5. Conformance With Plans** All activities authorized by this permit must be in strict conformance with the approved plans submitted by the applicant or applicant's agent as part of the permit application. Such approved plans were prepared by and approved by the county, municipality or their agents, and are on file at the county or municipal office.
- 6. Conditions Prevail Over Plans** If any condition of this permit conflicts with the approved plans, the permit condition shall prevail over the plans.

PRE-CONSTRUCTION REQUIREMENTS

- 7. Prohibited Streams and Rivers** This General Permit is not valid for use in the following regulated watercourses:

Great Chazy River from I-87 (Northway) downstream to lake Champlain;
West Branch Ausable River in its entirety;
Boquet River from the falls north of CR22 in Wadhams downstream to Lake Champlain;
Ausable River from Rainbow Falls downstream to Lake Champlain;
Saranac River from Kents Falls downstream to Lake Champlain;
Raquette River from Lower Falls downstream to the boat ramp off Rtes 3 & 30 (in the Town of Harrietstown);
Sacandaga River from the dam at the campground just north of the West Branch confluence downstream to Great Sacandaga Lake;
West Stony Creek from the State Forest Preserve boundary downstream to the Sacandaga River;
Sacandaga Lake outlet (to Lake Pleasant) in its entirety;
Batten Kill from the NY/VT border downstream to Center Falls.



8. Prohibition Period for In-water Work All in-water work, as well as any work that may result in the suspension of sediment, is prohibited during the trout and salmon spawning and incubation period commencing October 1 and ending April 30, unless prior project-specific approval is granted by the Department. Such approval shall be requested by checking "YES" following the question on the Authorization Form, and by providing written justification with submittal of the Form to the Regional Permit Administrator.

9. Precautions Against Contamination of Waters All necessary precautions shall be taken to preclude contamination of any wetland or waterway by suspended solids, sediments, fuels, solvents, lubricants, epoxy coatings, paints, concrete, leachate or any other environmentally deleterious materials associated with the project.

10. Creosote, Penta and CCA Use Prohibited The use of wood treated with creosote, Pentachlorophenol or CCA (Chromated Copper Arsenate) is prohibited for in-water and above-water use.

11. No Interference With Navigation There shall be no unreasonable interference with navigation by the work herein authorized.

12. Install and Maintain Erosion Controls Staked straw bales, silt fence or other DEC-approved erosion control measures are to be installed on the downslope edge of any disturbed areas. This barrier to sediments is to be put in place before any disturbance of the ground occurs and is to be maintained in a functional condition until all disturbed ground is heavily vegetated or otherwise stabilized. All erosion control measures intended to stabilize the work site shall be completed by October 1st of any calendar year. If work authorized by this permit cannot be completed by October 1st, interim stabilization measures consisting of erosion control matting or mulching shall be installed by October 1st and maintained in an effective condition until such time as authorized work resumes in the spring. Upon completion of work and satisfactory stabilization of disturbed areas, all erosion controls shall be entirely removed immediately.

13. Silt Screen If turbidity may be created as a result of this project, a silt screen curtain (maximum opening of U.S. Sieve No. 70) continually weighted across the bottom and suspended on floats or staked upright must be positioned to surround the work site. The curtain must remain in place for at least 12 hours after completion of the project or longer, if necessary.

14. No Impedance to Aquatic Organisms Structures must not impede upstream and downstream migration of aquatic organisms.

15. Return Stranded Fish Any fish remaining in the dewatered area shall be returned to the stream, lake or wetland.

16. Siltation Prevention Measures Siltation prevention measures, such as silt fencing, sediment traps or settling basins, shall be installed and maintained during the project, to prevent movement of silt and turbid waters from the project site into any watercourse, stream, water body or wetland.

17. Clearing of Vegetation and Snags Clearing of natural vegetation shall be limited to that material which poses a hazard or a hindrance to the authorized construction activity. Snags which provide shelter in streams for fish shall not be disturbed unless they cause serious obstructions, scouring or erosion. Trees shall not be felled onto the immediate banks or into any lake, stream or wetland.



18. Turbid Discharges Visibly turbid discharges from land clearing, grading or excavation activities, or de-watering operations shall not enter the stream, navigable water, or wetland. Prior to entry into stream, navigable water or wetland, any such discharge shall be retained in an appropriately maintained upland settling basin; filtered through crushed stone, sand, straw bales, silt screening (maximum opening size of U.S. Sieve Number 20), etc.; or directed to a grassy upland area a sufficient distance from the stream to prevent change in turbidity of the receiving water.

CONSTRUCTION REQUIREMENTS

19. Install Culvert in the Dry All culverts shall be installed in the dry. This may require constructing a cofferdam and/or pumping or piping the stream flow around the work area.

20. Cofferdam Specifications Any temporary cofferdam shall be constructed of materials such as sheet piling, sandbags or clean #1 or larger stone that will not contribute to turbidity or siltation of the waterbody. Sandbags shall be of the filter fabric type, double bagged and individually tied to prevent sand leakage. They shall be placed and removed manually to prevent spillage. Only clean sand free of debris, silt, fine particles, or other foreign substances shall be used to fill the bags. The cofferdam shall be entirely removed immediately upon completion of work.

21. Temporary Diversion Channel Any temporary diversion channel, culvert or pump-around shall be constructed to prevent running water in the work area. If a diversion channel is used, its sides and bottom shall be protected by rock riprap or other suitable non-erodible materials to prevent scour and erosion. The area of temporary diversion must be restored to its original condition following completion of the work.

22. Excavation for Authorized Structure Placement Only that excavation minimally necessary for proper placement of the permitted structure is authorized. Excavation or, including but not limited to, dredging of waterway or freshwater wetland bottom sediments, for any purpose other than those authorized by this GP is expressly prohibited.

23. Concrete Leachate No wet or fresh concrete or leachate shall be allowed to escape into any wetlands or waters of New York State, nor shall washings from ready-mixed concrete trucks, mixers, or other devices be allowed to enter any wetland or waters. Only watertight or waterproof forms shall be used. Wet concrete shall not be poured to displace water within the forms.

24. Bridge and Culvert Size For new or replacement bridges and culverts, the minimum bridge span (abutment to abutment) and culvert diameter or span shall be equal to or greater than 1.25 times the channel bed width. The channel bed width shall be an average width measured at the project location and straight sections of stream upstream and downstream, which are not influenced by structures or representative of unusual channel characteristics. If this condition cannot be met, an individual permit will be required. Notwithstanding the aforementioned, all such bridges and culverts must be designed to meet appropriate hydraulic capacity and structural integrity criteria.

25. Culvert Slope For streams which have a slope of three percent (3%) or less at the project area, the embedded culvert shall be installed with a zero percent (0%) slope. For streams which have a slope of more than 3% at the project area, a bottomless culvert or bridge must be installed. An individual permit is required for projects which deviate from this condition.



26. Embed Culverts All culverts with bottoms, including round culverts, must be installed so that at least 20% of the culvert's vertical height is embedded below the existing stream bed at the outlet end of the culvert. The streambed material that was excavated to accommodate culvert placement shall then be spread evenly throughout the bottom of the new culvert. If it is not practical to spread streambed material throughout the entire bottom of the new culvert, material must be spread in the culvert at the inlet and outlet ends gradually up to streambed elevation to promote natural deposition. Culverts with bottoms, including round culverts, shall not be installed if the placement is on bedrock.

27. Maintain Channel Geometry The stream channel bed width, depth and bank height immediately upstream and downstream of the project site shall be consistent with the average channel bed width of the stream. There shall be no widening or constriction of the stream channel bed through the road crossing, and no berms shall be constructed on the stream or river banks.

28. Maintain Water Flow During Work During periods of work activity, flow immediately downstream of the work site shall equal flow immediately upstream of the work site.

29. Riprap Placement Specifications All stone riprap shall be placed rather than dumped. Riprap shall be installed at a 1 vertical to 2 horizontal slope or flatter. During the bank sloping operation, soil shall not be pushed or placed into the stream bed or the flowing water, and shall not result in flow constriction. The stone riprap shall be placed on a layer of filter material such as gravel, small rock and/or woven filter cloth to provide positive drainage and soil stability. The placement of riprap shall not impede the movement of aquatic life. Riprap may not be consolidated with concrete or by any other means.

30. No Machinery in Waterbody or Wetland Machinery shall not be operated in or from any protected waterbody or in any portion of a regulated Freshwater Wetland without project-specific approval from the Department. However, with backhoes and similar heavy equipment, the bucket may enter the water or wetland, and is not considered operation in the water. Approval to operate machinery in or from the water shall be requested by checking "YES" following the question on the Authorization Form, and by providing written justification with submittal of the Form to the Regional Permit Administrator.

31. Fill and Riprap at Culvert Only compacted, clean earthen fill shall be used as backfill and fill around the culvert to minimize water infiltration around the culvert. Both ends of the culvert shall be adequately riprapped to prevent erosion and culvert failure during periods of high water flow.

32. Materials Disposed at Upland Site Any demolition debris, excess construction materials, and/or excess excavated materials shall be immediately and completely disposed of on an upland site more than 100 feet from any waterbody, including freshwater wetlands. These materials shall be suitably stabilized so as not to re-enter any water body, wetland, or wetland adjacent area.



33. Stabilize Disturbed Areas All disturbed stream banks **below** the normal high water elevation must be graded no steeper than 1 vertical to 2 horizontal slope, and adequately stabilized with stone riprap (native stone preferred). All other areas of soil disturbance **above** the ordinary high water elevation, or elsewhere, shall be seeded with a native perennial grass seed and mulched with straw within two (2) days of final grading. Mulch shall be maintained until suitable vegetative cover is established. Destroyed bank vegetation shall be replaced with shrub willow or silky dogwood plantings, for example, unless the natural growth disturbed consisted of species which immediately regenerate by "suckering."

34. Protect Stream, Wetland and Buffer From Road Runoff Roads, driveways and/or parking areas shall be graded to direct runoff away from streams, freshwater wetlands and/or adjacent areas where possible. The road banks within 50 feet of the stream shall be adequately protected with riprap or seeded and mulched within 2 days of completion of the crossing. If the protection consists of seeding and mulching, growth of vegetative cover must become successfully established. If vegetation fails to successfully establish, the area must be replanted until successful vegetation establishment is achieved.

35. State Not Liable for Damage The State of New York shall in no case be liable for any damage or injury to the structure or work herein authorized which may be caused by or result from future operations undertaken by the State for the conservation or improvement of navigation, or for other purposes, and no claim or right to compensation shall accrue from any such damage.

36. State May Order Removal or Alteration of Work If future operations by the State of New York require an alteration in the position of the structure or work herein authorized, or if, in the opinion of the Department of Environmental Conservation it shall cause unreasonable obstruction to the free navigation of said waters or flood flows or endanger the health, safety or welfare of the people of the State, or cause loss or destruction of the natural resources of the State, the owner may be ordered by the Department to remove or alter the structural work, obstructions, or hazards caused thereby without expense to the State, and if, upon the expiration or revocation of this permit, the structure, fill, excavation, or other modification of the watercourse hereby authorized shall not be completed, the owners, shall, without expense to the State, and to such extent and in such time and manner as the Department of Environmental Conservation may require, remove all or any portion of the uncompleted structure or fill and restore to its former condition the navigable and flood capacity of the watercourse. No claim shall be made against the State of New York on account of any such removal or alteration.

37. State May Require Site Restoration If upon the expiration or revocation of this permit, the project hereby authorized has not been completed, the applicant shall, without expense to the State, and to such extent and in such time and manner as the Department of Environmental Conservation may lawfully require, remove all or any portion of the uncompleted structure or fill and restore the site to its former condition. No claim shall be made against the State of New York on account of any such removal or alteration.

WATER QUALITY CERTIFICATION SPECIFIC CONDITIONS

1. Water Quality Certification The NYS Department of Environmental Conservation hereby certifies that the subject project will not contravene effluent limitations or other limitations or standards under Sections 301, 302, 303, 306 and 307 of the Clean Water Act of 1977 (PL 95-217) provided that all of the conditions listed herein are met.



GENERAL CONDITIONS - Apply to ALL Authorized Permits:

1. Facility Inspection by The Department The permitted site or facility, including relevant records, is subject to inspection at reasonable hours and intervals by an authorized representative of the Department of Environmental Conservation (the Department) to determine whether the permittee is complying with this permit and the ECL. Such representative may order the work suspended pursuant to ECL 71- 0301 and SAPA 401(3).

The permittee shall provide a person to accompany the Department's representative during an inspection to the permit area when requested by the Department.

A copy of this permit, including all referenced maps, drawings and special conditions, must be available for inspection by the Department at all times at the project site or facility. Failure to produce a copy of the permit upon request by a Department representative is a violation of this permit.

2. Relationship of this Permit to Other Department Orders and Determinations Unless expressly provided for by the Department, issuance of this permit does not modify, supersede or rescind any order or determination previously issued by the Department or any of the terms, conditions or requirements contained in such order or determination.

3. Applications For Permit Renewals, Modifications or Transfers The permittee must submit a separate written application to the Department for permit renewal, modification or transfer of this permit. Such application must include any forms or supplemental information the Department requires. Any renewal, modification or transfer granted by the Department must be in writing. Submission of applications for permit renewal, modification or transfer are to be submitted to:

Regional Permit Administrator

4. Submission of Renewal Application The permittee must submit a renewal application at least 30 days before permit expiration for the following permit authorizations: Excavation & Fill in Navigable Waters, Freshwater Wetlands, Stream Disturbance, Water Quality Certification.

5. Permit Modifications, Suspensions and Revocations by the Department The Department reserves the right to exercise all available authority to modify, suspend or revoke this permit. The grounds for modification, suspension or revocation include:

- a. materially false or inaccurate statements in the permit application or supporting papers;
- b. failure by the permittee to comply with any terms or conditions of the permit;
- c. exceeding the scope of the project as described in the permit application;



- d. newly discovered material information or a material change in environmental conditions, relevant technology or applicable law or regulations since the issuance of the existing permit;
- e. noncompliance with previously issued permit conditions, orders of the commissioner, any provisions of the Environmental Conservation Law or regulations of the Department related to the permitted activity.

6. Permit Transfer Permits are transferrable unless specifically prohibited by statute, regulation or another permit condition. Applications for permit transfer should be submitted prior to actual transfer of ownership.

NOTIFICATION OF OTHER PERMITTEE OBLIGATIONS

Item A: Permittee Accepts Legal Responsibility and Agrees to Indemnification

The permittee, excepting state or federal agencies, expressly agrees to indemnify and hold harmless the Department of Environmental Conservation of the State of New York, its representatives, employees, and agents ("DEC") for all claims, suits, actions, and damages, to the extent attributable to the permittee's acts or omissions in connection with the permittee's undertaking of activities in connection with, or operation and maintenance of, the facility or facilities authorized by the permit whether in compliance or not in compliance with the terms and conditions of the permit. This indemnification does not extend to any claims, suits, actions, or damages to the extent attributable to DEC's own negligent or intentional acts or omissions, or to any claims, suits, or actions naming the DEC and arising under Article 78 of the New York Civil Practice Laws and Rules or any citizen suit or civil rights provision under federal or state laws.

Item B: Permittee's Contractors to Comply with Permit

The permittee is responsible for informing its independent contractors, employees, agents and assigns of their responsibility to comply with this permit, including all special conditions while acting as the permittee's agent with respect to the permitted activities, and such persons shall be subject to the same sanctions for violations of the Environmental Conservation Law as those prescribed for the permittee.

Item C: Permittee Responsible for Obtaining Other Required Permits

The permittee is responsible for obtaining any other permits, approvals, lands, easements and rights-of-way that may be required to carry out the activities that are authorized by this permit.

Item D: No Right to Trespass or Interfere with Riparian Rights

This permit does not convey to the permittee any right to trespass upon the lands or interfere with the riparian rights of others in order to perform the permitted work nor does it authorize the impairment of any rights, title, or interest in real or personal property held or vested in a person not a party to the permit.

ESSEX COUNTY PURCHASING
7551 COURT STREET – PO BOX 217
ELIZABETHTOWN, NY 12932

NON-BIDDER RESPONSE

Bid/RFP Name: _____

The Essex County Purchasing Department is interested in the reasons why bidders fail to submit bids. Please indicate your reason(s) by checking all appropriate item(s) below and returning this form to the above address.

- Could not meet specifications or Scope of Services.
- Items or materials requested not manufactured by us or not available to our company.
- Insurance Requirements are too restricting.
- Bond requirements are too restricting.
- Specifications or Scope of Services not clearly understood or applicable (too vague, too rigid, etc.)
- Project not suited to firm,
- Quantities too small.
- Insufficient time allowed for preparation of bid.
- Other reasons; please state and define:

Vendor Name: _____

Contact Person: _____

Vendor Address: _____

Vendor Telephone: _____

Appendix A
Utility Work Agreements

(This page intentionally left blank)

FEDERAL AID – LOCAL PROJECTS
UTILITY WORK AGREEMENT

Since the construction, reconstruction, or maintenance of the transportation project described below, identified as:

Capital Project Identification No. 1760.68

F.A. Project No. 1760.68

ROW Declaration No. _____

Map Nos. _____

Parcel Nos. _____

County of Essex

Contract No. _____

Project Description: Campsite Road over the Hudson River

necessitates the adjustment of utility facilities as hereinafter described, the owner, NYSEG, of said facilities herewith agrees with the Local Sponsor that this agreement shall apply to the accommodation of these utility facilities. Any adjustment of said facilities will be accomplished under the terms of this agreement, in accordance with the Rules and Regulations Governing the Accommodation of Utilities within the State Highway Right-of-Way, in compliance with the attached Special Notes and in accordance with the contract plans, specifications, proposal, amendment(s) or change order(s).

I. Existing Facilities (describe type, size, capacity, location, etc.)

The existing structure does not carry any utilities. The overhead electric utilities and communication lines on Campsite Road cross the Hudson River parallel to the south fascia of the bridge. The utilities are presently located on Essex County and Town of Newcomb Right-of-Way as shown on the plans for the proposed transportation project. The utilities are to be adjusted as follows:

NYSEG to permanently relocate two (2) utility poles, one on each bridge approach south of the bridge, to the north side of the bridge. NYSEG is to install an additional pole along the southwest side of Campsite Road west of the bridge to span between utility poles and prevent unnecessary tree removal. NYSEG shall relocate the electric lines, components and existing light system to the new utility poles. NYSEG to remove the existing two (2) utility poles. If deem necessary for construction by the contractor, NYSEG shall de-energize the overhead electric lines for up to a maximum duration of four (4) hours. Contractor shall notify NYSEG a minimum of three (3) weeks prior to desired de-energized date, as stated in the attached special note. See attached Disposition of Utilities Worksheet and General Plan. The work shall be completed within three (3) weeks from formal notification to proceed.

for an estimated \$0.00.

II. Financial Responsibility in Accordance with Section 81 of the Highway Law (check appropriate boxes):

- A. The facilities to be adjusted under the terms of this agreement are subject to Section 52 of the State Highway Law, and the cost of this adjustment is the sole responsibility of the owner.
- B. Subdivision 24 of Section 10 of the State Highway Law enables the Local sponsor to provide at the expense of the State, for adjustment to a municipally owned utility when such work is necessary as a result of State highway work.
- C. Subdivision 24-b of Section 10 of the State Highway Law enables the Local Sponsor to participate in the necessary expenses incurred for adjustment of privately, publicly or cooperatively owned facilities, municipal utility facilities, or facilities of a corporation organized pursuant to the State Transportation Corporation's law.
- D. The owner will develop and keep a record of costs in accordance with the New York State Department of Transportation (NYSDOT) Utility Reimbursement Procedure Manual, and with the Federal Highway Administration (FHWA) Federal Aid Policy Guide, Part 645, or as indicated below:

III. Physical Adjustment Method (check appropriate boxes):

The actual adjustment or design engineering will be performed by the following method(s):

- 1) Contract let by the Local Sponsor _____
- 2) Contract let by the Owner (check applicable statement):
 - a. Best Interests of Local Sponsor
 - b. Owner not sufficiently staffed or equipped.
- 3) By the Owner's forces _____

IV. Betterment, Salvage, and Depreciation Credits Due the Project (check appropriate boxes):

- 1) There will be no extension of service life, improved capacity or any other betterment of the facility (as defined by the Utility Reimbursement Procedure Manual and by FHWA Federal Aid Policy Guide Part 645) as a result of the adjustments made pursuant to this agreement.
- 2) There is betterment described as follows:

- 3) The owner will not claim reimbursement for that betterment portion of the work, but will duly account for it as required by applicable NYSDOT and FHWA procedures.
- 4) The owner agrees to comply with the requirements of the NYSDOT Utility Reimbursement Procedure and FHWA Federal Aid Policy Guide Part 645 with the respect to salvage and depreciation credits when applicable.

V. General Covenants

The owner hereby agrees to accept full title and responsibility for the adjusted facility in writing upon satisfactory completion of the work. Such acceptance will acknowledge the owner's responsibility to maintain the facility in accordance with all applicable codes, standards and regulations, including his obligation, where applicable, to remove any or all of the facility from the highway all in accordance with the Rules and Regulations Governing the Accommodation of Utilities within the State Highway Right-of-Way. All compensable claims covered by this agreement will be included in one of the following:

1. A Privately Owned Property Agreement executed prior to the performance of the work.
2. A Municipal Agreement executed prior to performance of the work.
3. Such other agreement as approved by NYSDOT Office of Legal Affairs

VI. References

The following documents are herewith incorporated in this agreement by reference (check appropriate boxes):

- A. Federal Highway Administration's Federal Aid Policy Guide Part 645.
- B. Contract Documents: Contract number _____
Capital PIN 1760.68
Plan sheets No. GP-1 & ST-1
- C. Owner's Plan Sheets _____
- D. Owner's estimate sheets form No. _____
- E. Resolution Dated _____ by _____
- Granting the Local Sponsor authority to perform the adjustment for the owner.
- Agreeing to maintain facilities adjusted via Local-let contract.
- F. Certification by the owner or his agent that he has the legal authority to enter into this agreement

<i>Kim Marie Dickey</i>	<i>Kim Marie Dickey</i>	Supervisor	2/13/19
(Print/Type Name - Owner or Agent)	Signature	Title	Date
<i>Christa He</i>	<i>Christa He</i>	Superintendent	2-13-19
For Local Sponsor	Signature	Title	Date

For NYSDOT Commissioner of Transportation	Title	Date
---	-------	------

(This page intentionally left blank)

DISPOSITION OF UTILITIES

Campsite Road over Hudson River

TOWN OF NEWCOMB, ESSEX COUNTY, NEW YORK

Date: January 17, 2019

UTILITY REFERENCE NUMBER OR DESCRIPTION	LOCATION BY CENTERLINE STATION	OFFSET FROM CENTERLINE		UTILITIES AFFECTED							PROPOSED DESIGN CONFLICT WITH EXISTING UTILITIES	RELOCATION REQUIRED		PRESENT LOCATION		DISTANCE OF ROW FROM EXISTING CL		DISTANCE FROM EXISTING CL TO TOP OR TOE OF SLOPE		MINIMUM DISTANCE UTILITIES MUST BE MOVED	REMARKS
		LEFT	RIGHT	POWER	TELEPHONE	CABLE	GAS	WATER	SEWER	OTHER (FIBER)		YES	NO	EXISTING ROW	PRIVATE	LT	RT	LT	RT		
Campsite Road over the Hudson River																					
P.P. W/LIGHT E12 L1103	02+83	26.3 ft		X	X	X				X	Overhead line will interfere with constr.	X		X		36.5 ft	32.8 ft	36.5 ft (TOE)	32.8 ft (TOP)	Opposite side of road within the ROW	Existing pole to be removed by NYSEG, new pole to be installed by NYSEG
P.P. E12A	05+08	20.0 ft		X	X	X				X	Overhead line will interfere with constr.	X		X		29.9 ft	35.1 ft	29.9 ft (TOE)	28.8 ft (TOE)	Opposite side of road within the ROW	Existing pole to be removed by NYSEG, new pole to be installed by NYSEG
P.P. X	N/A		N/A								Utility preferred to add an additional pole	N/A	N/A	N/A	N/A		N/A			N/A	Proposed pole to be installed by NYSEG to reduce current span length and prevent additional tree removal.

(This page intentionally left blank)

SPECIAL NOTE

COORDINATION WITH THE UTILITY SCHEDULE

In addition to requirements and/or explanations contained in Sections 102-02, 102-03, 103-05, 105-06 and 107-05 of the Standard Specifications dated January 1, 2019, Section 100-Phase 5A, the Contractor is advised of the following:

All known public, private or municipal utility lines within or adjacent to the site of the work, are shown in the existing approximate locations on the project plans. The Contractor is cautioned that these locations are not guaranteed; nor is there a guarantee that all such lines in existence have been shown on the plans.

The Contractor shall conduct his operations as to prevent damage to such facilities. He shall make such explorations as may be necessary to determine the dimensions and locations of lines that may be subject to damage. Notification to the various owners of facilities shall be given in accordance with New York State Industrial Code 753.

The Contractor shall conduct his operations in accordance with all OSHA rules and regulations and in accordance with New York State Labor Law, Section 202-h, "The High Voltage Proximity Act".

The Contractor shall satisfy himself as to the exact location of utility lines and shall protect and support in a suitable manner all utilities encountered in his work. The Contractor shall make good any damage to those utilities caused by his operations. If the nature of the damage is such as to endanger the satisfactory operations of the utilities, and the necessary repairs are not immediately made by the Contractor, the work may be done by the respective owning companies and the cost thereof charged against the Contractor.

The Contractor specifically agrees that he has included in his unit prices and lump sum prices, bid for the various items of the contract, any additional cost of doing the work under this contract because of the fact that he might not have a clear site for the work and because of interference of the roadway use by the utilities and the necessity or desirability of opening certain sections of pavement to traffic before the entire work is completed.

The Contractor must coordinate his schedule of operations with the various Utility owners and/or municipalities involved with the project and shall verify utility information found in the contract documents. Utility revisions required by the various Utility owners in connection with this project include:

New York State Electric and Gas (NYSEG)

NYSEG will relocate the overhead electric lines along the south side of the bridge to the north side. This will involve relocating poles E12-L1103 and E12A to the locations consistent with the disposition of utilities worksheet and with the contract plans. In addition a new pole will be placed by NYSEG on the southwest side of the road approximately 231 ft west of the existing bridge joint. NYSEG shall be required to complete their work within three (3) weeks after receipt of the notification indicating that the site is prepared and accessible for NYSEG to start working. If determined necessary for erection of steel girder the contractor may request the utility lines to be de-energized for a maximum duration of four (4) hours. Contractor shall coordinate with NYSEG a minimum of three (3) weeks prior to the requested de-energized date.

In addition to the above itemized revisions, other additions may become necessary during the construction phase as a result of more precise location data or other changes that might develop. Suitable time frames for these additions shall be coordinated between the Contractor and the utility companies. Such time frames are not to be included within previously established time frames.

The contact at NYSEG is Paul Blakelock, 4125 Route 22, Plattsburgh, NY 12901. He may be contacted at (518) 484-3798.

Frontier Communications

Frontier Communications will relocate their overhead communication lines to the new poles installed by NYSEG as outlined in the *Disposition of Utilities Worksheet* and consistent with the contract plans. Frontier Communications shall be required to complete their work within three (3) weeks after NYSEG has relocated the poles. If a request to de-energized the electric lines has been made to NYSEG the contractor shall also notify Frontier.

In addition to the above itemized revisions, other additions may become necessary during the construction phase as a result of more precise location data or other changes that might develop. Suitable time frames for these additions shall be coordinated between the Contractor and the utility companies. Such time frames are not to be included within previously established time frames.

The contact at Frontier Communications is Dan McDermott, 137 Harrison St, Gloversville, NY 12078. He may be contacted at (518) 773-6112.

FILE NAME = N:\Proj\p1214\2017\117-050\Campsite\cadd\dgr\117-050-cpb.gmn_01.dgn
 DATE/TIME = 1/17/2019
 USER = ABrown

DESIGN SUPERVISOR C. TUTUNJIAN JOB MANAGER C. TUTUNJIAN DESIGN L. SHORT DRAFTING K. DETRICK CHECK A. BROWN CHECK A. BROWN PROJECT MANAGER C. TUTUNJIAN

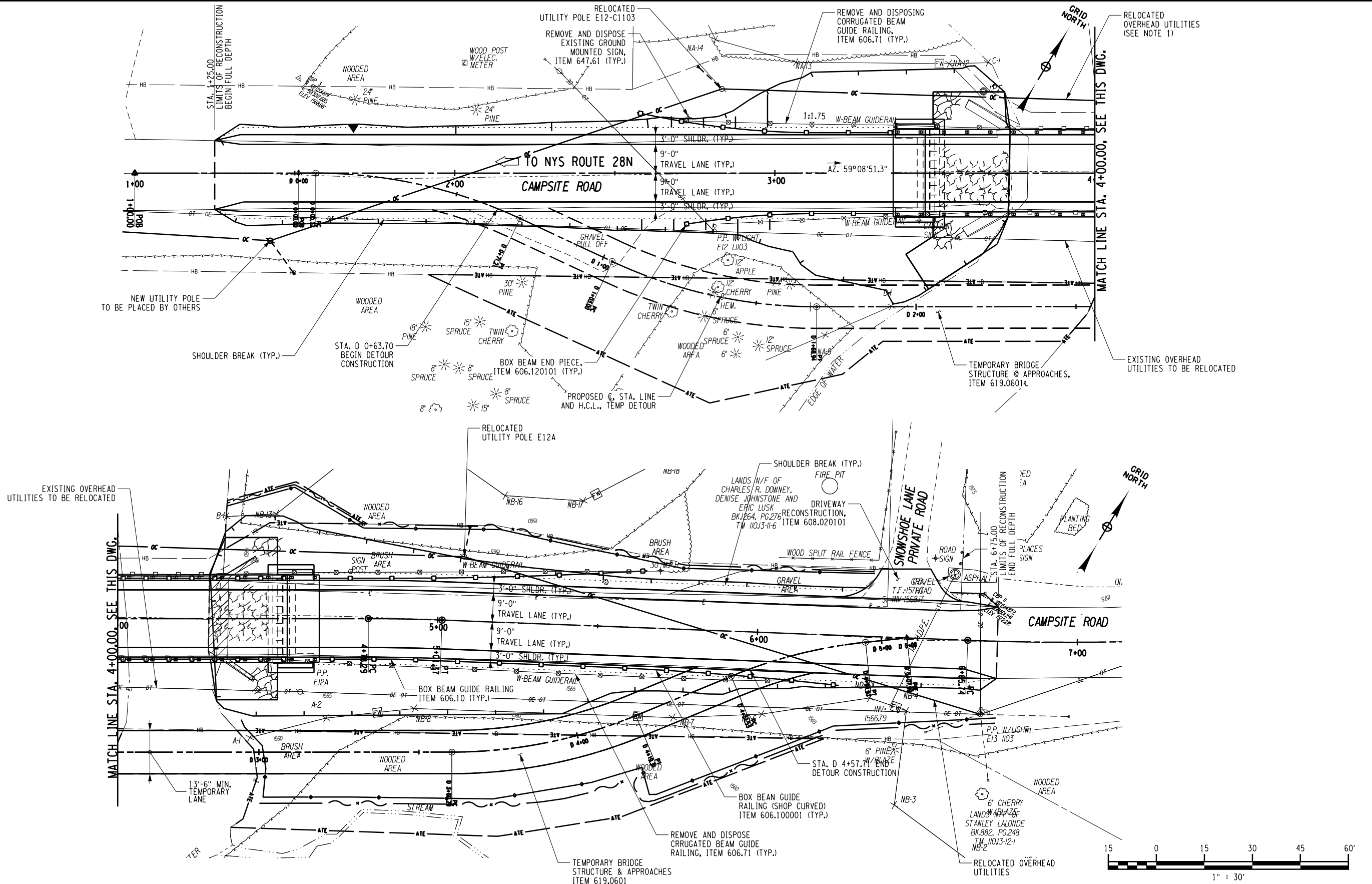

NOTES:

- UTILITIES TO BE RELOCATED BY OTHERS. CONTRACTOR TO COORDINATE WITH UTILITY COMPANIES. SEE UTILITY COORDINATION SPECIAL NOTE.

AS-BUILT REVISIONS DESCRIPTION OF ALTERATIONS:	CAMPSITE ROAD OVER HUDSON RIVER	PIN 1760.68	BRIDGES BIN 3302040	CULVERTS	ALL DIMENSIONS IN FT UNLESS OTHERWISE NOTED	CONTRACT NUMBER
	BRIDGE REPLACEMENT PROJECT					
	TOWN OF NEWCOMB COUNTY: ESSEX REGION: 1					
HIGHWAY GENERAL PLAN					DRAWING NO. GP-1 SHEET NO. 11 OF 38	

IT IS A VIOLATION OF LAW FOR ANY PERSON, UNLESS THEY ARE ACTING UNDER THE DIRECTION OF A LICENSED PROFESSIONAL ENGINEER, ARCHITECT, LANDSCAPE ARCHITECT, OR LAND SURVEYOR, TO ALTER AN ITEM IN ANY WAY. IF AN ITEM BEARING THE STAMP OF A LICENSED PROFESSIONAL IS ALTERED, THE ALTERING ENGINEER, ARCHITECT, LANDSCAPE ARCHITECT, OR LAND SURVEYOR SHALL STAMP THE DOCUMENT AND INCLUDE THE NOTATION "ALTERED BY" FOLLOWED BY THEIR SIGNATURE, THE DATE OF SUCH ALTERATION, AND A SPECIFIC DESCRIPTION OF THE ALTERATION.

PROJECT MANAGER C. TUTUNJIAN
 CHECK A. BROWN
 DRAFTING K. DETRICK
 CHECK A. BROWN
 DESIGN L. SHORT
 JOB MANAGER C. TUTUNJIAN
 FILE NAME = N:\Proj\6214\2017\117-050\Campsite\cadd\dgr\117-050-cpb.gmn_02.dgn
 DATE/TIME = 1/17/2019
 USER = ABrown

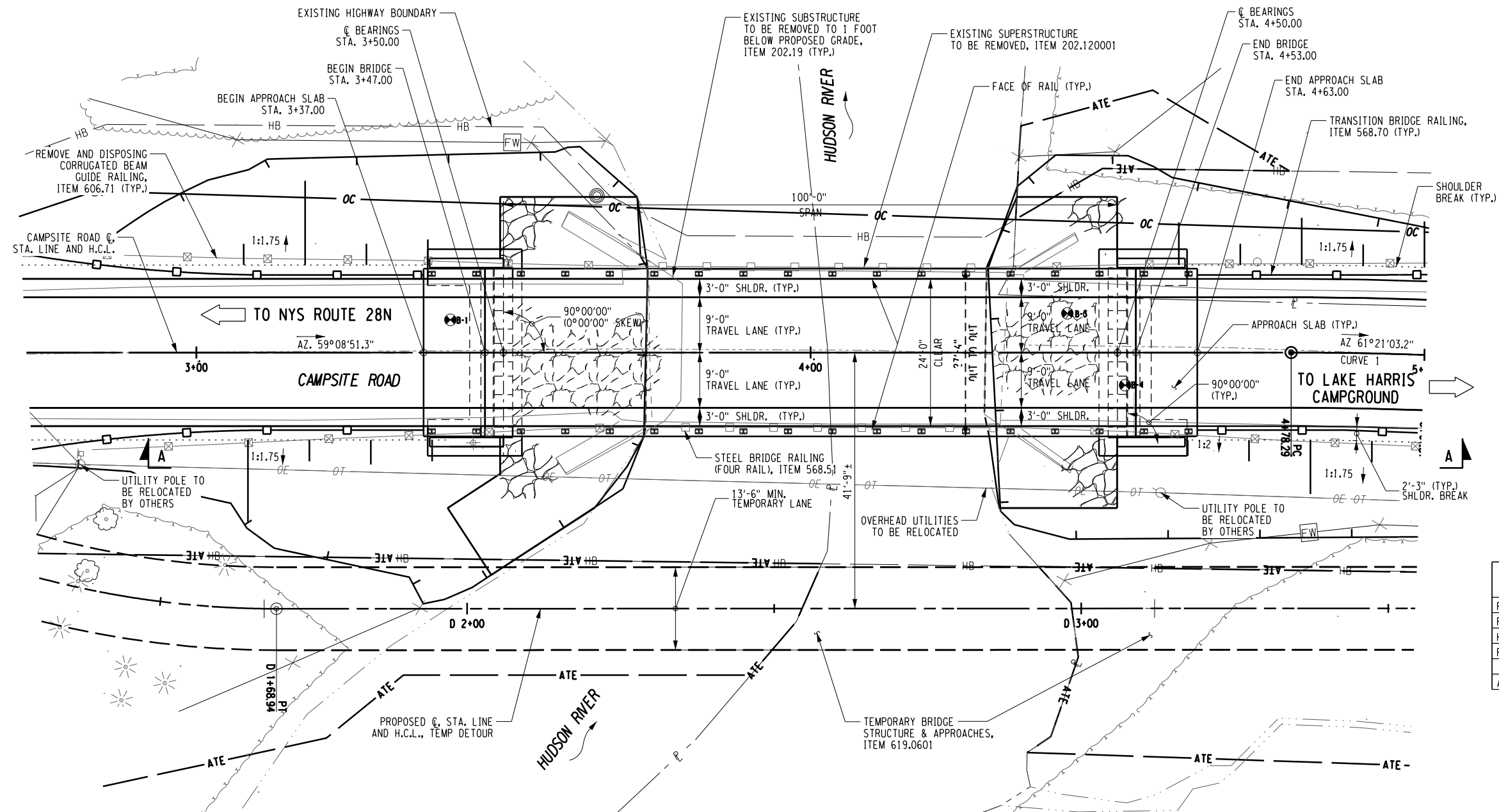

HYDRAULIC DATA		BASE FLOOD	DESIGN FLOOD
DRAINAGE AREA = 116 SQ. MI.			
FREQUENCY INTERVALS (YEARS)		100	50
PEAK DISCHARGE (CFS)		7680	6780
HIGH WATER ELEV. (FT)		1563.4	1562.7
FREEBOARD PROVIDED (FT)		EXIST 0.1	0.7
		PROP. 1.3	2.0
AVG. VELOCITY @ STRUCTURE (FT/S)		9.92	8.85

LOAD RATING (LOAD FACTOR)		
INVENTORY	MS	TONS
OPERATING	MS	TONS

- TEMPORARY STRUCTURE NOTE**
- THE PROPOSED TEMPORARY STRUCTURE SHALL PROVIDE A MINIMUM CLEAR OPENING OF 78 FT. PERPENDICULAR TO THE FLOW WITH A MINIMUM ACCEPTABLE LOW BEAM ELEVATION OF 1562.42. A MINIMUM CLEAR WATERWAY AREA OF 646.5 SF IS REQUIRED BELOW THE MINIMUM LOW BEAM ELEVATION.
 - FOR PURPOSES OF THIS STRUCTURE, MULTIPLE PIPES OR CELLS WILL NOT BE ACCEPTABLE.

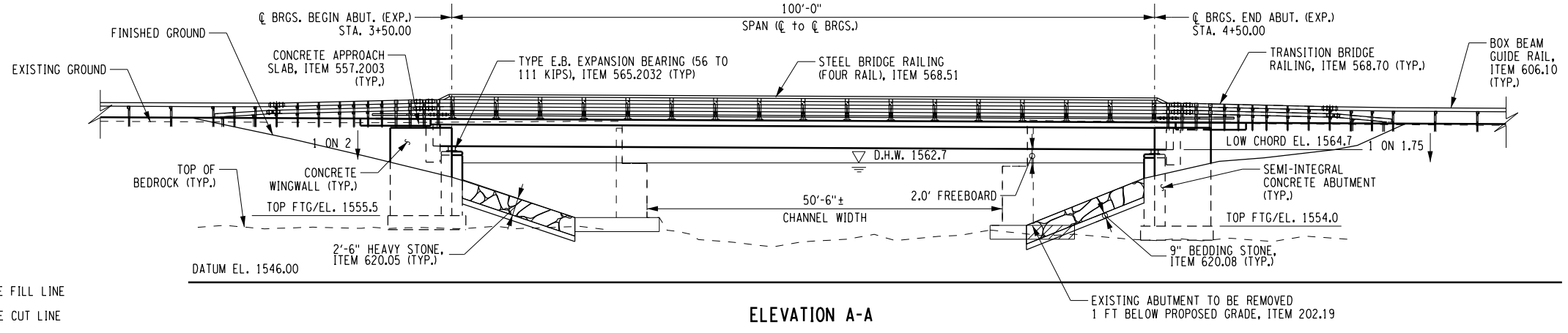

CURVE 1	
PC = STA. 4+78.29	
PT = STA. 5+01.37	
Δ = 2°12'11.92"	
R = 600.00'	
Dc = 9°32'57.47"	
L = 23.07'	
T = 11.54'	

LEGEND:

- APPROXIMATE FILL LINE
- APPROXIMATE CUT LINE
- BORING LOCATION & DESIGNATION
- HEAVY STONE FILLING, ITEM 620.05

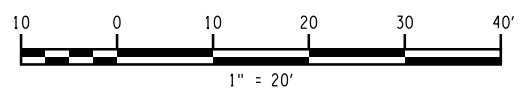

AS-BUILT REVISIONS DESCRIPTION OF ALTERATIONS:	CAMPSITE ROAD OVER HUDSON RIVER	PIN 1760.68	BRIDGES	CULVERTS	ALL DIMENSIONS IN FT UNLESS OTHERWISE NOTED	CONTRACT NUMBER
	BRIDGE REPLACEMENT PROJECT		BIN 3302040			GENERAL PLAN & ELEVATION
	TOWN OF NEWCOMB	REGION: 1				SHEET NO. 13 OF 38

IT IS A VIOLATION OF LAW FOR ANY PERSON, UNLESS THEY ARE ACTING UNDER THE DIRECTION OF A LICENSED PROFESSIONAL ENGINEER, ARCHITECT, LANDSCAPE ARCHITECT, OR LAND SURVEYOR, TO ALTER AN ITEM IN ANY WAY. IF AN ITEM BEARING THE STAMP OF A LICENSED PROFESSIONAL IS ALTERED, THE ALTERING ENGINEER, ARCHITECT, LANDSCAPE ARCHITECT, OR LAND SURVEYOR SHALL STAMP THE DOCUMENT AND INCLUDE THE NOTATION "ALTERED BY" FOLLOWED BY THEIR SIGNATURE, THE DATE OF SUCH ALTERATION, AND A SPECIFIC DESCRIPTION OF THE ALTERATION.

FEDERAL AID – LOCAL PROJECTS
UTILITY WORK AGREEMENT

Since the construction, reconstruction, or maintenance of the transportation project described below, identified as:

Capital Project Identification No. 1760.68 F.A. Project No. 1760.68
ROW Declaration No. _____ Map Nos. _____
Parcel Nos. _____ County of Essex
Contract No. _____

Project Description: Campsite Road over the Hudson River

necessitates the adjustment of utility facilities as hereinafter described, the owner, FRONTIER COMMUNICATIONS, of said facilities herewith agrees with the Local Sponsor that this agreement shall apply to the accommodation of these utility facilities. Any adjustment of said facilities will be accomplished under the terms of this agreement, in accordance with the Rules and Regulations Governing the Accommodation of Utilities within the State Highway Right-of-Way, in compliance with the attached Special Notes and in accordance with the contract plans, specifications, proposal, amendment(s) or change order(s).

I. Existing Facilities (describe type, size, capacity, location, etc.)

The existing structure does not carry any utilities. The overhead electric utilities and communication lines on Campsite Road cross the Hudson River parallel to the south fascia of the bridge. The utilities are presently located on Essex County and Town of Newcomb Right-of-Way as shown on the plans for the proposed transportation project. The utilities are to be adjusted as follows:

NYSEG to permanently relocate two (2) utility poles, one on each bridge approach south of the bridge, to the north side of the bridge. NYSEG is to install an additional pole along the southwest side of Campsite Road west of the bridge to span between utility poles and prevent unnecessary tree removal. Once new poles are in place Frontier Communication shall relocate the communication lines to the new utility poles. See attached Disposition of Utilities Worksheet and General Plan. The work shall be completed within three (3) weeks from the pole relocation by NYSEG.

for an estimated \$0.00.

II. Financial Responsibility in Accordance with Section 81 of the Highway Law (check appropriate boxes):

- A. The facilities to be adjusted under the terms of this agreement are subject to Section 52 of the State Highway Law, and the cost of this adjustment is the sole responsibility of the owner.

- B. Subdivision 24 of Section 10 of the State Highway Law enables the Local sponsor to provide at the expense of the State, for adjustment to a municipally owned utility when such work is necessary as a result of State highway work.
- C. Subdivision 24-b of Section 10 of the State Highway Law enables the Local Sponsor to participate in the necessary expenses incurred for adjustment of privately, publicly or cooperatively owned facilities, municipal utility facilities, or facilities of a corporation organized pursuant to the State Transportation Corporation's law.
- D. The owner will develop and keep a record of costs in accordance with the New York State Department of Transportation (NYSDOT) Utility Reimbursement Procedure Manual, and with the Federal Highway Administration (FHWA) Federal Aid Policy Guide, Part 645, or as indicated below:

III. Physical Adjustment Method (check appropriate boxes):

The actual adjustment or design engineering will be performed by the following method(s):

- 1) Contract let by the Local Sponsor _____
- 2) Contract let by the Owner (check applicable statement):
 - a. Best Interests of Local Sponsor
 - b. Owner not sufficiently staffed or equipped.
- 3) By the Owner's forces _____

IV. Betterment, Salvage, and Depreciation Credits Due the Project (check appropriate boxes):

- 1) There will be no extension of service life, improved capacity or any other betterment of the facility (as defined by the Utility Reimbursement Procedure Manual and by FHWA Federal Aid Policy Guide Part 645) as a result of the adjustments made pursuant to this agreement.
- 2) There is betterment described as follows:

- 3) The owner will not claim reimbursement for that betterment portion of the work, but will duly account for it as required by applicable NYSDOT and FHWA procedures.
- 4) The owner agrees to comply with the requirements of the NYSDOT Utility Reimbursement Procedure and FHWA Federal Aid Policy Guide Part 645 with the respect to salvage and depreciation credits when applicable.

V. General Covenants

The owner hereby agrees to accept full title and responsibility for the adjusted facility in writing upon satisfactory completion of the work. Such acceptance will acknowledge the owner's responsibility to maintain the facility in accordance with all applicable codes, standards and regulations, including his obligation, where applicable, to remove any or all of the facility from the highway all in accordance with the Rules and Regulations Governing the Accommodation of Utilities within the State Highway Right-of-Way. All compensable claims covered by this agreement will be included in one of the following:

- 1. A Privately Owned Property Agreement executed prior to the performance of the work.
- 2. A Municipal Agreement executed prior to performance of the work.
- 3. Such other agreement as approved by NYSDOT Office of Legal Affairs

VI. References

The following documents are herewith incorporated in this agreement by reference (check appropriate boxes):

- A. Federal Highway Administration's Federal Aid Policy Guide Part 645.
- B. Contract Documents: Contract number _____
Capital PIN 1760.68
Plan sheets No. GP-1 & ST-1
- C. Owner's Plan Sheets _____
- D. Owner's estimate sheets form No. _____
- E. Resolution Dated _____ by _____
- Granting the Local Sponsor authority to perform the adjustment for the owner.
- Agreeing to maintain facilities adjusted via Local-let contract.
- F. Certification by the owner or his agent that he has the legal authority to enter into this agreement

Daniel J. McDermott Daniel J. McDermott - ^{FRONTIER COMM} Network Engr. 1/30/19
 (Print/Type Name - Owner or Agent) Signature Title Date

Christina Heu _____ 2-13-19
 For Local Sponsor Title Date

 For NYSDOT Commissioner of Transportation Title Date

(This page intentionally left blank)

DISPOSITION OF UTILITIES

Campsite Road over Hudson River

TOWN OF NEWCOMB, ESSEX COUNTY, NEW YORK

Date: January 17, 2019

UTILITY REFERENCE NUMBER OR DESCRIPTION	LOCATION BY CENTERLINE STATION	OFFSET FROM CENTERLINE		UTILITIES AFFECTED							PROPOSED DESIGN CONFLICT WITH EXISTING UTILITIES	RELOCATION REQUIRED		PRESENT LOCATION		DISTANCE OF ROW FROM EXISTING CL		DISTANCE FROM EXISTING CL TO TOP OR TOE OF SLOPE		MINIMUM DISTANCE UTILITIES MUST BE MOVED	REMARKS
		LEFT	RIGHT	POWER	TELEPHONE	CABLE	GAS	WATER	SEWER	OTHER (FIBER)		YES	NO	EXISTING ROW	PRIVATE	LT	RT	LT	RT		
Campsite Road over the Hudson River																					
P.P. W/LIGHT E12 L1103	02+83	26.3 ft		X	X	X				X	Overhead line will interfere with constr.	X		X		36.5 ft	32.8 ft	36.5 ft (TOE)	32.8 ft (TOP)	Opposite side of road within the ROW	Existing pole to be removed by NYSEG, new pole to be installed by NYSEG
P.P. E12A	05+08	20.0 ft		X	X	X				X	Overhead line will interfere with constr.	X		X		29.9 ft	35.1 ft	29.9 ft (TOE)	28.8 ft (TOE)	Opposite side of road within the ROW	Existing pole to be removed by NYSEG, new pole to be installed by NYSEG
P.P. X	N/A		N/A								Utility preferred to add an additional pole	N/A	N/A	N/A	N/A		N/A			N/A	Proposed pole to be installed by NYSEG to reduce current span length and prevent additional tree removal.

(This page intentionally left blank)

SPECIAL NOTE

COORDINATION WITH THE UTILITY SCHEDULE

In addition to requirements and/or explanations contained in Sections 102-02, 102-03, 103-05, 105-06 and 107-05 of the Standard Specifications dated January 1, 2019, Section 100-Phase 5A, the Contractor is advised of the following:

All known public, private or municipal utility lines within or adjacent to the site of the work, are shown in the existing approximate locations on the project plans. The Contractor is cautioned that these locations are not guaranteed; nor is there a guarantee that all such lines in existence have been shown on the plans.

The Contractor shall conduct his operations as to prevent damage to such facilities. He shall make such explorations as may be necessary to determine the dimensions and locations of lines that may be subject to damage. Notification to the various owners of facilities shall be given in accordance with New York State Industrial Code 753.

The Contractor shall conduct his operations in accordance with all OSHA rules and regulations and in accordance with New York State Labor Law, Section 202-h, "The High Voltage Proximity Act".

The Contractor shall satisfy himself as to the exact location of utility lines and shall protect and support in a suitable manner all utilities encountered in his work. The Contractor shall make good any damage to those utilities caused by his operations. If the nature of the damage is such as to endanger the satisfactory operations of the utilities, and the necessary repairs are not immediately made by the Contractor, the work may be done by the respective owning companies and the cost thereof charged against the Contractor.

The Contractor specifically agrees that he has included in his unit prices and lump sum prices, bid for the various items of the contract, any additional cost of doing the work under this contract because of the fact that he might not have a clear site for the work and because of interference of the roadway use by the utilities and the necessity or desirability of opening certain sections of pavement to traffic before the entire work is completed.

The Contractor must coordinate his schedule of operations with the various Utility owners and/or municipalities involved with the project and shall verify utility information found in the contract documents. Utility revisions required by the various Utility owners in connection with this project include:

New York State Electric and Gas (NYSEG)

NYSEG will relocate the overhead electric lines along the south side of the bridge to the north side. This will involve relocating poles E12-L1103 and E12A to the locations consistent with the disposition of utilities worksheet and with the contract plans. In addition a new pole will be placed by NYSEG on the southwest side of the road approximately 231 ft west of the existing bridge joint. NYSEG shall be required to complete their work within three (3) weeks after receipt of the notification indicating that the site is prepared and accessible for NYSEG to start working. If determined necessary for erection of steel girder the contractor may request the utility lines to be de-energized for a maximum duration of four (4) hours. Contractor shall coordinate with NYSEG a minimum of three (3) weeks prior to the requested de-energized date.

In addition to the above itemized revisions, other additions may become necessary during the construction phase as a result of more precise location data or other changes that might develop. Suitable time frames for these additions shall be coordinated between the Contractor and the utility companies. Such time frames are not to be included within previously established time frames.

The contact at NYSEG is Paul Blakelock, 4125 Route 22, Plattsburgh, NY 12901. He may be contacted at (518) 484-3798.

Frontier Communications

Frontier Communications will relocate their overhead communication lines to the new poles installed by NYSEG as outlined in the *Disposition of Utilities Worksheet* and consistent with the contract plans. Frontier Communications shall be required to complete their work within three (3) weeks after NYSEG has relocated the poles. If a request to de-energized the electric lines has been made to NYSEG the contractor shall also notify Frontier.

In addition to the above itemized revisions, other additions may become necessary during the construction phase as a result of more precise location data or other changes that might develop. Suitable time frames for these additions shall be coordinated between the Contractor and the utility companies. Such time frames are not to be included within previously established time frames.

The contact at Frontier Communications is Dan McDermott, 137 Harrison St, Gloversville, NY 12078. He may be contacted at (518) 773-6112.

FILE NAME = N:\Proj\p1214\2017\117-050\Campsite\cadd\dgr\117-050-cpb.gmn_01.dgn
 DATE/TIME = 1/17/2019
 USER = ABrown

DESIGN SUPERVISOR C. TUTUNJIAN JOB MANAGER C. TUTUNJIAN DESIGN L. SHORT DRAFTING K. DETRICK CHECK A. BROWN CHECK A. BROWN PROJECT MANAGER C. TUTUNJIAN

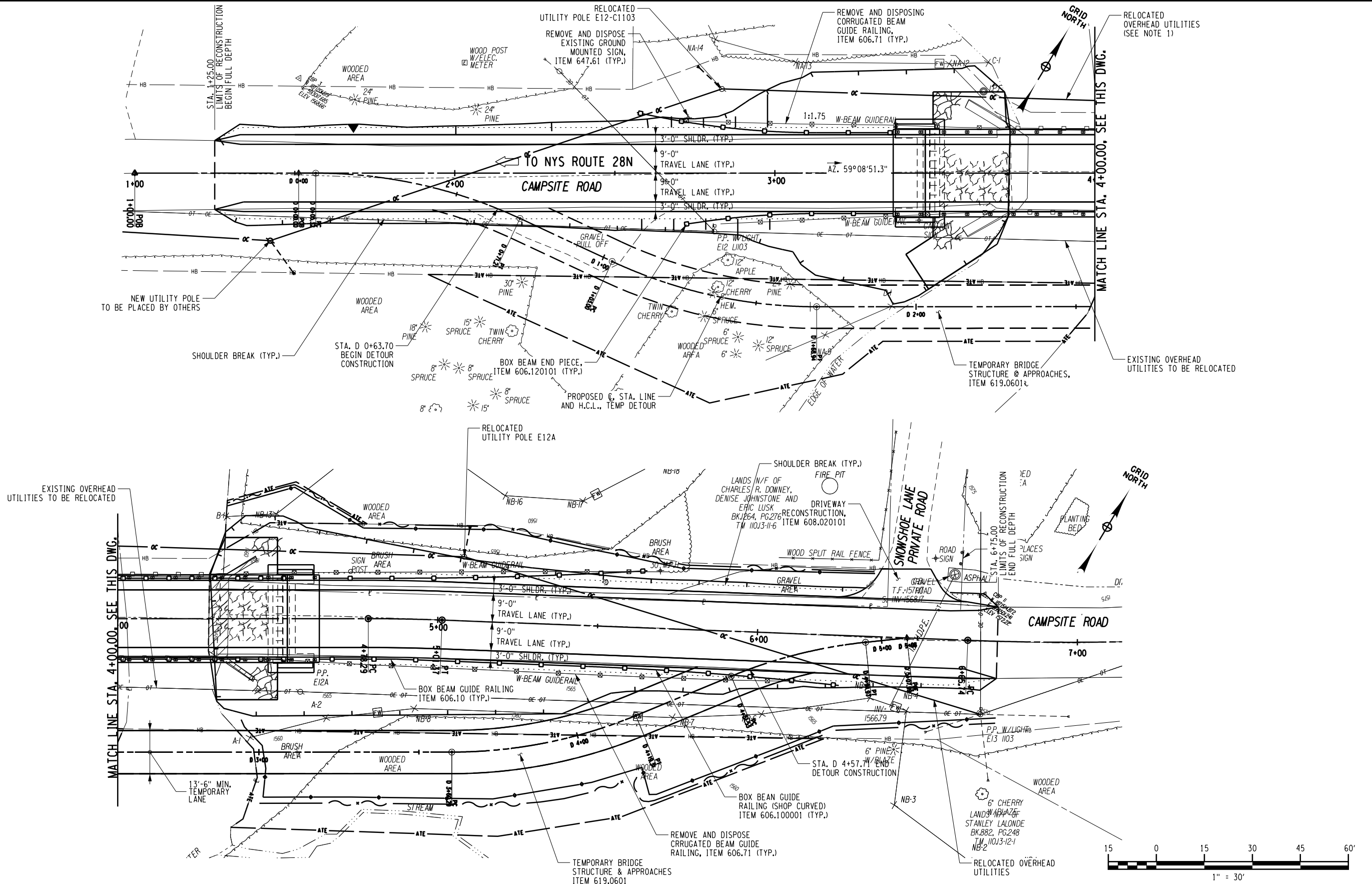

NOTES:

- UTILITIES TO BE RELOCATED BY OTHERS. CONTRACTOR TO COORDINATE WITH UTILITY COMPANIES. SEE UTILITY COORDINATION SPECIAL NOTE.

AS-BUILT REVISIONS DESCRIPTION OF ALTERATIONS:	CAMPSITE ROAD OVER HUDSON RIVER	PIN 1760.68	BRIDGES	CULVERTS	ALL DIMENSIONS IN FT UNLESS OTHERWISE NOTED	CONTRACT NUMBER
	BRIDGE REPLACEMENT PROJECT		BIN 3302040			
	TOWN OF NEWCOMB COUNTY: ESSEX	REGION: 1				HIGHWAY GENERAL PLAN

IT IS A VIOLATION OF LAW FOR ANY PERSON, UNLESS THEY ARE ACTING UNDER THE DIRECTION OF A LICENSED PROFESSIONAL ENGINEER, ARCHITECT, LANDSCAPE ARCHITECT, OR LAND SURVEYOR, TO ALTER AN ITEM IN ANY WAY. IF AN ITEM BEARING THE STAMP OF A LICENSED PROFESSIONAL IS ALTERED, THE ALTERING ENGINEER, ARCHITECT, LANDSCAPE ARCHITECT, OR LAND SURVEYOR SHALL STAMP THE DOCUMENT AND INCLUDE THE NOTATION "ALTERED BY" FOLLOWED BY THEIR SIGNATURE, THE DATE OF SUCH ALTERATION, AND A SPECIFIC DESCRIPTION OF THE ALTERATION.

PROJECT MANAGER: C. TUTUNJIAN
 CHECK: A. BROWN
 DRAFTING: K. DETRICK
 CHECK: A. BROWN
 DESIGN: L. SHORT
 JOB MANAGER: C. TUTUNJIAN
 FILE NAME: N:\Proj\mcs\2017\117-050\Campsite\cadd\dgr\117-050-cpb.gmn_02.dgn
 DATE/TIME: 1/17/2019
 USER: ABrown

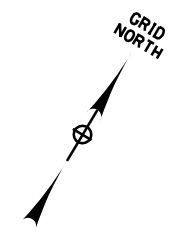
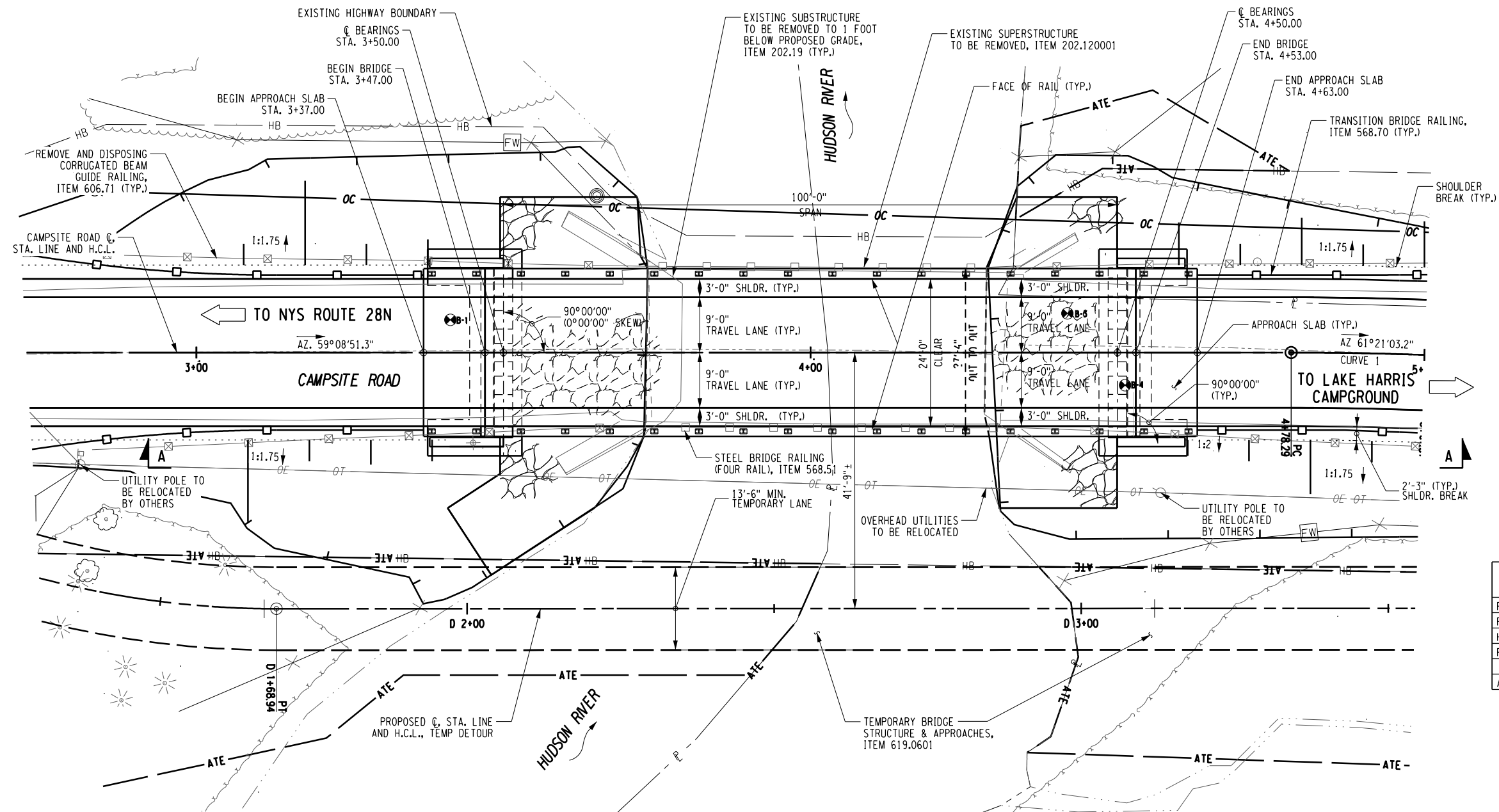

HYDRAULIC DATA		BASE FLOOD	DESIGN FLOOD
DRAINAGE AREA = 116 SQ. MI.			
FREQUENCY INTERVALS (YEARS)		100	50
PEAK DISCHARGE (CFS)		7680	6780
HIGH WATER ELEV. (FT)		1563.4	1562.7
FREEBOARD PROVIDED (FT)		EXIST 0.1	0.7
		PROP. 1.3	2.0
AVG. VELOCITY @ STRUCTURE (FT/S)		9.92	8.85

LOAD RATING (LOAD FACTOR)		
INVENTORY	MS	TONS
OPERATING	MS	TONS

TEMPORARY STRUCTURE NOTE

1. THE PROPOSED TEMPORARY STRUCTURE SHALL PROVIDE A MINIMUM CLEAR OPENING OF 78 FT. PERPENDICULAR TO THE FLOW WITH A MINIMUM ACCEPTABLE LOW BEAM ELEVATION OF 1562.42. A MINIMUM CLEAR WATERWAY AREA OF 646.5 SF IS REQUIRED BELOW THE MINIMUM LOW BEAM ELEVATION.
2. FOR PURPOSES OF THIS STRUCTURE, MULTIPLE PIPES OR CELLS WILL NOT BE ACCEPTABLE.

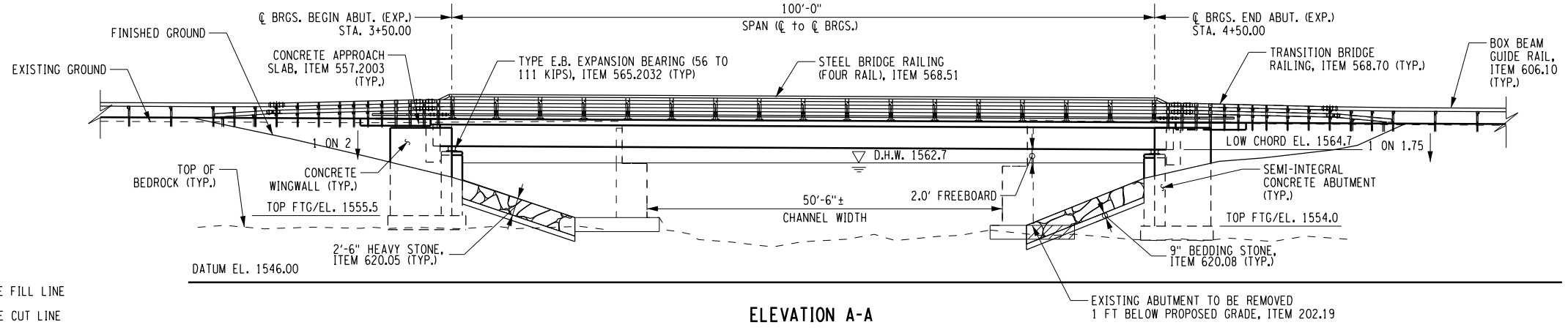

CURVE 1	
PC =	STA. 4+78.29
PT =	STA. 5+01.37
Δ =	2°12'11.92"
R =	600.00'
Dc =	9°32'57.47"
L =	23.07
T =	11.54'

LEGEND:

- APPROXIMATE FILL LINE
- APPROXIMATE CUT LINE
- BORING LOCATION & DESIGNATION
- HEAVY STONE FILLING, ITEM 620.05

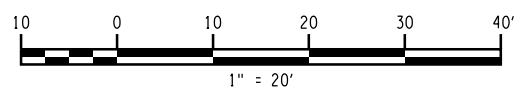

AS-BUILT REVISIONS DESCRIPTION OF ALTERATIONS:	CAMPSITE ROAD OVER HUDSON RIVER	PIN 1760.68	BRIDGES	CULVERTS	ALL DIMENSIONS IN FT UNLESS OTHERWISE NOTED	CONTRACT NUMBER
	BRIDGE REPLACEMENT PROJECT		BIN 3302040			GENERAL PLAN & ELEVATION
	TOWN OF NEWCOMB	REGION: 1				SHEET NO. 13 OF 38

IT IS A VIOLATION OF LAW FOR ANY PERSON, UNLESS THEY ARE ACTING UNDER THE DIRECTION OF A LICENSED PROFESSIONAL ENGINEER, ARCHITECT, LANDSCAPE ARCHITECT, OR LAND SURVEYOR, TO ALTER AN ITEM IN ANY WAY. IF AN ITEM BEARING THE STAMP OF A LICENSED PROFESSIONAL IS ALTERED, THE ALTERING ENGINEER, ARCHITECT, LANDSCAPE ARCHITECT, OR LAND SURVEYOR SHALL STAMP THE DOCUMENT AND INCLUDE THE NOTATION "ALTERED BY" FOLLOWED BY THEIR SIGNATURE, THE DATE OF SUCH ALTERATION, AND A SPECIFIC DESCRIPTION OF THE ALTERATION.

Appendix B
Right-Of-Way Clearance Certificate

(This page intentionally left blank)

RIGHT OF WAY CLEARANCE CERTIFICATE

To: Regional Real Estate Officer, Region 1 Date: 2/12/19 Design Approval Date: 7/11/2018

From: Chris Garrow Sponsor: Essex County DPW
P.I.N: 1760.68 Project: Campsite Rd. Over Hudson River Bridge Replacemer
Sponsor ID #: N/A Acquiring Agency: RK Hite

I certify that; the right-of-way has been or will be acquired in accordance with the Highway Law, the Eminent Domain Procedure Law (when applicable), Uniform Relocation Assistance Real Property Acquisition Policies Act of 1970 as amended, and Title 23 of the Code of Federal Regulations, Part 635, Section 309 and that the status of the right-of-way is as follows:

Select: a, b, c or d

(a) No right of way (including clearance of encroachments conflicting with the project construction within the existing right of way) is required for the project.

(b) All of the necessary rights of way, including control of access rights have been acquired (legal and physical possession). All payments/deposits are completed. If applicable, "Statement of Donations" attached. There are no improvements existing that need to be removed or demolished and/or all occupants have vacated the land and/or improvements and the acquiring agency has the physical possession and the right to remove.

(c) All the necessary rights of way, including control of access rights have not been completed, however, the acquisitions are being progressed and all legal and physical possession will be completed prior to advertisement of the contract (see attached ROW 9-15ALL "Acquisition and Clearance Status Report" for completion schedule).

(d) Acquisition of one or more remaining properties has not been completed and will not be completed prior to project advertisement for bids. All eligible occupants of the residences, if any, on such properties have had replacement housing made available to them in accordance with 49 CFR 24.204. (See attached ROW 9-15ALL "Acquisition and Clearance Status Report" for completion schedule and ROW 9-16ALL "Special Note – Availability of ROW"). The completion schedule will be included in the contract plans, engineering substantiation and a report of the quantity and quality of relocation assistance. A note designating the lack of availability shall appear on the specific plan sheet of each indicated property. FHWA approval of this (these) projection(s) is required.

(Reasons property may not be available include acquisitions of properties in bankruptcy, acquisitions from cemeteries, acquisitions from the federal/state government, and relocations.)

Project description:

No. of maps required for project	<u>3</u>
No. of Claimants	<u>3</u>
No. of maps not requiring payment	<u>3</u>
No. of Relocations required	<u>0</u>
No. of Relocations completed	<u>0</u>
No. of maps paid to date	<u>0</u>
No. of maps deposited to date	<u>0</u>

Completed Project Checklist and Property Checklist must be attached.

Responsible Local Official Date: 2/12/19
Name and Title: Chris Garrow, Superintendent of Public Works

NYSDOT Real Estate Officer Date: _____

(This page intentionally left blank)

Appendix C
Environmental Permits

(This page intentionally left blank)



**Adirondack
Park Agency**

APA General Permit
2002G-3AAR

Permit Number:
2018-0126

P.O. Box 99 · Ray Brook, New York
12977 (518) 891-4050 ·
(518) 891-3938
www.apa.ny.gov

Application and Certification for Certain Minor
Regulated Activities in APA-jurisdictional Freshwater
Wetlands

Instructions: Please answer all of the questions in each section and complete the required attachments. Submit this form with the required attachments in person or by mail to the Deputy Director, Regulatory Programs, Adirondack Park Agency at the above address. A site visit by Agency staff is required. You may not begin regulated activities at the project site until you have received this certification signed by Agency staff.

Section A

Name of Project Sponsor: **Essex County** Authorized Representative: **Creighton Manning**

Mailing Address: **2 Winners Cir Albany NY 12205** **Engineering**

Telephone Number (daytime): **518-689-1823** FAX: **518-446-0397**

Prior Agency Contact:

Have you had any previous discussions with Agency staff regarding the proposed activities involving wetlands or has any Agency staff visited the project site with you or your representative?

No
 Yes, staff person's name: **Ms. Tracy Darrah, Jurisdictional Inquiry J2018-0027**
Date of Contact: **February 02, 2018**

Has the project site been the subject of a past Agency action (i.e., project permit, order, variance, jurisdictional inquiry, enforcement case or wetland flagging)?

No
 Do not know
 Yes, If known, provide the following number and date:

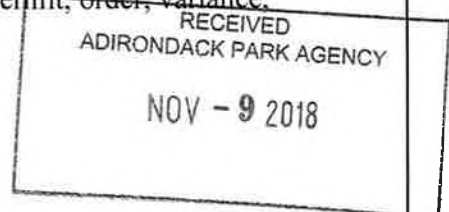

Past Project Permit, Order or Variance Number: _____
Jurisdictional Inquiry Number: **J2018-0027**
Enforcement Case Number: _____
Wetland Boundary Flagging : _____

Contractor (if any, doing the proposed work in wetlands): **TBD**

Name of Company: _____ Authorized Representative: _____

Mailing Address: _____

Telephone No: _____ FAX: _____

Project Site Location:

Town(s): Newcomb Village: N/A County (ies): Essex

Nearby Road(s): Route 28N Nearby Waterbody: Lake Harris/Hudson River

Tax Map Number (s): (list all involved parcels): 3 temporary easements required outside the project ROW limits

Section 110 Block 1 Parcel 27.100 Section 110.13 Block 12 Parcel 1
 " " 110.13 " " 11 " " 6

Brief Project Description:

This project proposes to replace the existing structure with a new 100 ft single span bridge on Campsite Road in the Town of Newcomb. The new structure will be set with a longer span to improve the hydraulics at the bridge. The bridge will be built on the existing horizontal alignment to minimize impacts to the surrounding land resources. Construction of the new bridge will require the accommodation of traffic on site since Campsite Road is a dead end. This will be accomplished by utilizing a temporary bridge located adjacent to the new bridge to the south. Wetlands are present on all quadrants of the bridge as shown on the attached map. This project anticipates only temporary impacts to the surrounding wetlands for the construction of the temporary detour road. This section of the Hudson River is also on the Recreational Rivers list.

By signing this permit application, the project sponsors agree to strictly comply with the terms and conditions of this application and certification.

X *Annika Palmer*
 Signature of Project sponsor

X N/A Same as sponsor
 Signature of Project Site Landowner(s)

X *Alexander Brown*
 Signature of Authorized Representative(s) (if designated above)

Section B

Certain Regulated Activities in Wetlands

- Applicability:**
1. This general permit only applies where the sole basis of Agency permit jurisdiction over the project activity in question is due to involvement of wetlands pursuant to Section 810(1) of the APA Act or where the activity constitutes a "regulated activity" pursuant to 9 NYCRR 578.3 in or significantly impairing wetlands.
 2. This general permit may not be used if the wetland activity in question also requires Agency approval due to involvement of a larger project, such as a subdivision or new land use or development under Sections 810 or 814 of the Adirondack Park Agency Act or for "rivers projects" under the New York State Wild, Scenic and Recreational Rivers System Act and 9 NYCRR Part 577 or requires a variance under Section 806 shoreline restrictions.

Field Visit Requirements: (to be completed by the project project sponsor prior to the field visit by Agency staff unless otherwise agreed to in advance by Agency staff)

1. Field delineate with stakes the centerline of any driveways, roads, underground or overhead utilities, utility poles, culverts or other structures to be located within wetlands.
2. Field delineate with stakes or colored flagging (except blue) the approximate location of all property lines that are located within 100 feet of the edge of any proposed work area.
3. Identify with colored flagging (except blue) or stakes the limits of the proposed temporary and/or permanent fill in wetlands.
4. Field delineate with stakes any new power poles to be located in wetlands.

Required Attachments: (your application will not be processed without all required attachments)

1. Attach a copy of current deed of record for the project site.
2. Attach a Property Boundary Map which may be either a labeled and scaled copy of a survey map, deed plot or current real property tax map clearly showing the property boundaries and labeled with the tax map number(s).
3. Attach a site plan map scaled at 1" = 40' (one inch equals forty feet) for each work site involving or affecting wetlands. Showing existing site conditions and the proposed development activities, including all existing and proposed roads, driveways, buildings, utility poles, lines and anchors, and drainage structures, temporary and permanent easements, areas of existing vegetation labeled as to covertime, limits of proposed vegetative clearing, existing wetland boundaries, limits of wetland disturbance or filling, and proposed mitigation, including wetland replacement areas, if any. The map should clearly show the date and name and title of the person who prepared the map.
4. Provide scaled sketches of the proposed work areas and activities, including plan view and cross sections through the area of wetland fill, plans and details of any temporary or permanent structures to be placed in or affecting wetlands, and temporary and permanent erosion and sediment control practices to be employed.
5. Attach a written explanation describing all of the following:
 - a) The purpose and need for the proposed activity involving or affecting existing wetlands,
 - b) why there is no practicable alternative to avoid working in the wetlands,
 - c) how impacts to the wetlands have been avoided and minimized to the greatest extent practicable,
 - d) the quantity in square feet of temporary excavation or fill and permanent excavation or fill,
 - e) all temporary and permanent erosion and sediment control practices to be used to protect the wetlands during and after construction,

- f) final site stabilization and restoration methods (e.g., topsoiling and seeding, planting of trees and shrubs), including plant names and sizes,
- g) all other proposed compensatory mitigation measures, including constructing replacement wetlands, if any, and construction activities sequence of work and proposed start date and estimated completion date.

Section C

CONDITIONS

1. The activities in or affecting existing APA-jurisdictional wetlands described in this application and in the required attachments may not be undertaken unless or until this application and certification is signed by authorized Agency staff.
2. Failure to comply with this general permit and approved attached site plan is a violation and may subject the project sponsor, successors and assigns to civil penalties and other legal proceedings, including modification, suspension or revocation of the permit.
3. By signing the application and certification, the permittee(s) and their contractor(s), if any, accept full legal responsibility for all damages, direct or indirect, of whatever nature and by whomever suffered, arising out of the project.
4. The Agency may conduct on-site investigations, examinations and evaluations as it deems necessary to ensure compliance with the terms and conditions of this permit. Such activities shall take place at reasonable times and upon advance notice where possible.
5. At the written request of the Agency, the permittee shall report in writing the status of the project, including details of compliance with any terms and conditions of this permit.
6. The permittee shall notify the Agency in writing of the project completion within five working days after the work authorized by the approved permit has been successfully completed.
7. All mobilization of equipment and materials shall occur prior to undertaking the work involving or affecting wetlands and shall be completed in the shortest necessary time span.
8. This permit does not grant the permittee any right to trespass upon the lands of, or interfere with the riparian rights of others in order to perform the permitted work, nor does it authorize the impairment of any rights, title, or interest in real or personal property held or vested in a person not a party to the permit.
9. The permittee shall require that any agent, contractor, project engineer, or other person responsible for the overall supervision of this project read and understand this permit and approved plans and all terms and conditions prior to undertaking the project. Copies of the signed permit and approved plans shall be kept at the project site during all construction activities.
10. Any deviation from the type of project authorized by this permit or failure to comply precisely with all the terms and conditions of this permit and approved plans must be expressly approved in writing and in advance by authorized staff of the Agency.
11. The work shall be scheduled and conducted during drier periods (not during major storm events,

- shall be kept at the project site during all construction activities.
10. Any deviation from the type of project authorized by this permit or failure to comply precisely with all the terms and conditions of this permit and approved plans must be expressly approved in writing and in advance by authorized staff of the Agency.
 11. The work shall be scheduled and conducted during drier periods (not during major storm events, spring runoff, and thawing conditions) to avoid and minimize erosion of soils and to prevent silting and muddying of wetlands or surface waterbodies.
 12. Prior to construction, including clearing and grubbing, silt fence, as shown on the approved plans, shall be properly installed with the bottom buried at least four inches. Silt fence and all other erosion control measures shall be installed and maintained as specified in and shown on the approved plans.
 13. No mechanized equipment shall be driven in wetlands unless expressly authorized herein. Every effort shall be made to work from upland areas and to minimize disturbances to areas adjacent to wetlands. Only tracked equipment shall be used in wetlands.
 14. Any cutting of vegetation along the shorelines of navigable waterbodies shall be in conformance with the Shoreline Restrictions of Section 806 of the Adirondack Park Agency Act. (A copy of the Shoreline Restrictions or the Citizen's Guide is available upon request).
 15. No waste disposal, material or excavation stockpiling, or dewatering discharge shall occur in or within 50 feet of wetlands unless specifically authorized in the project plans.
 16. All equipment, including but not limited to trucks, excavators, earth drills and tractors, shovels, picks and rakes, to be used on the site shall be washed with high pressure hoses and hot water prior to being brought on the site. The intent of this condition is to insure invasive plant species are not spread to the construction site.
 17. The regulated wetland activities authorized herein, including site restoration activities, shall be completed by October 15, 2020.

SPECIAL CONDITIONS BY ACTIVITY

Underground utility line installation, repair or replacement

18. The installation or repair of underground utility lines shall not result in significant change in the preconstruction contours, flow or watertable characteristics of the wetland.
19. The area of wetland disturbance shall be limited to the minimum necessary to construct the utility line. Clearing of existing vegetation shall be limited to that material which poses an immediate hazard or hindrance to construction activities. Grading and grubbing of the wetland shall be minimized to the greatest extent practicable.
20. Where trenching for the installation or repair of underground utilities in wetlands, the top 12 inches of wetland soil shall be first removed and temporarily placed onto a geo-textile blanket running parallel to the trench. Sub-grade soils dug from the trench shall be sidecast on the opposite side of the trench

soil should be left 3 to 6 inches above the surrounding undisturbed wetland surface to allow for settling. All excess material must be removed to upland areas and stabilized immediately upon completion of construction. The geo-textile blanket can be utilized for the next trench section or rolled up and taken offsite after the work is completed.

Culvert repairs, replacements, and extensions or new installations in wetlands

22. Existing pipe and box culverts shall be replaced at their existing location. Replacement culverts shall be installed so as to preserve the pre-construction water levels and flows and shall not inhibit the natural movement of fish. If the activity involves a DEC classified stream, also obtain and comply with an ECL Article 15 permit.
23. New culverts shall be installed so as to preserve the preconstruction water levels and flows and shall not inhibit the natural movement of fish.

Temporary access or detour drives, work pads or water control structures in wetlands

24. Any fills required for temporary construction access, detour and work pad facilities shall be of clean, heavy stone fill or other non-erodible material placed on geo-textile fabric up to the ordinary high water elevation.
25. Temporary construction access, detour and work pad facilities (including necessary fills) shall be located so as to avoid or minimize disturbance of the wetland, and appropriate temporary drainage measures must be taken to maintain preconstruction water flows and watertable characteristics.
26. Temporary water control structures (i.e. cofferdams) shall be of the type and size, and shall be placed in such a manner, so as to not impair surface water flow into or out of the wetland.
27. Temporary water control structures (i.e. cofferdams) shall be constructed of non-erodible materials, and located in such a manner, so as to prevent its dispersion or movement by normal or high water flows.
28. Temporary construction access, detour and work pad facilities (including necessary fills) shall be entirely removed following completion of construction activities, and the affected and adjacent area successfully restored to its preconstruction condition, including replacement planting of native trees and shrubs.

Widening or improvements to existing roads, driveways, or trails

29. Any permanent fill associated with widening or improvements to a pre-August 1, 1973 road, driveway or trail shall not exceed 300 square feet of permanent wetland excavation or fill per wetland complex. Compensatory mitigation shall be addressed as approved by Agency staff.
30. The placement of earthen fill for widening of pre-August 1, 1973 highways, bridges, driveways or trails shall be limited to the minimum necessary to bring the facility into

compliance with current State design, safety and capacity standards and shall only be allowed as long as the proposed activity or improvement does not change the historic use of the facility and the property or the character of the setting.

31. Stabilize road fill with native seed and straw or wood fiber mulch or rip rap, as approved, within 3 days of completion of fill activities.

Temporary access in wetlands for survey and exploratory activities

32. Any fills required for temporary access facilities shall be of clean, heavy stone fill or other non-erodible material placed on geo-textile fabric up to the ordinary high water elevation.
33. All test wells, test pits and bore holes located in wetlands shall be backfilled to the fullest extent possible with soil excavated from the well, pit or hole, with the upper 12 inches of wetland soil returned to the top of the hole. All excess material shall be immediately removed from the wetland and adjacent area and stabilized immediately upon completion of the activity.
34. The area of wetland disturbance shall be limited to the minimum necessary to perform the survey and/or exploratory activity. Cutting of existing vegetation shall be limited to that material which poses an immediate hazard or hindrance to the necessary activity. All cut vegetation shall be immediately removed from the wetland and adjacent area upon completion of the activity. Grubbing of stumps and roots shall be avoided.
35. Temporary access facilities (including necessary fills) shall be located so as to avoid or minimize disturbance of the wetland, and appropriate measures shall be taken to maintain preconstruction water flows and watertable characteristics.
36. Temporary access facilities (including necessary fills) shall be entirely removed following completion of the necessary activity, and the affected wetland and adjacent area shall be graded, seeded and restored to replicate preconstruction conditions (except that the planting of replacement trees and shrubs is not required).
37. All slurries, dusts, and liquids and other materials brought to the surface during drilling activities will be carried or pumped into an upland location and treated in such manner so that they or any effluent derived from them are not deposited into the wetland.

Overhead Utility Pole and Line Repair or Replacement

38. The area of wetland disturbance shall be limited to the minimum necessary to repair, replace or construct the utility pole and line. Clearing of existing vegetation shall be limited to that material which poses an immediate hazard or hindrance to construction activities. Grading and grubbing of the wetland shall be minimized to the greatest extent practicable.
39. When pole replacements occur in wetlands, the existing poles to be replaced shall be removed

Overhead Utility Pole and Line Repair or Replacement

38. The area of wetland disturbance shall be limited to the minimum necessary to repair, replace or construct the utility pole and line. Clearing of existing vegetation shall be limited to that material which poses an immediate hazard or hindrance to construction activities. Grading and grubbing of the wetland shall be minimized to the greatest extent practicable.
39. When pole replacements occur in wetlands, the existing poles to be replaced shall be removed completely from the wetland, including that portion of the pole that was buried.
40. Whenever practicable, access through wetlands shall be done on frozen ground or with the use of wide-tracked vehicles. If temporary access or work pads are required, they shall be governed by the Conditions 22 thru 26 listed above.
41. No hay bales shall be allowed on the project site and only straw bales that meet the requirements of NYSDOT material specification 713-19- straw, shall be allowed on the project site.
42. This permit authorizes the construction of the temporary access roads and bridge and the replacement bridge in the location shown and as depicted on the "Wetland Restoration Plan, Sheet 1 of 6" (dated November 9, 2018), "General Plan and Elevation, Sheet 2 of 6" and sheets 3, 4, 5 and 6 (Sections and Profiles) of the final plans prepared by Creighton Manning and dated November 7, 2018. Any change to the location, dimensions, or other aspect of the bridge replacement project shall require a new or amended permit or prior written Agency authorization.
43. Pursuant to Section 809(2)(a) of the Adirondack Park Agency Act/9 NYCRR §577.4, the undertaking of any new land use or development not authorized herein on the project site within one-quarter mile of the Hudson River on Rural use lands will require a new or amended permit. The undertaking of any regulated activity involving wetlands, not authorized herein, also requires a new or amended permit.

X 

Signature of APA Environmental Program Specialist ~~or Wetlands Biologist~~
(Required before regulated activity can be started)

Date: 12/14/18

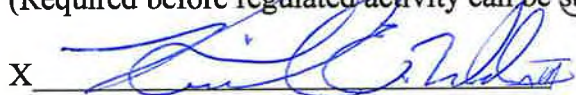
X 

Signature of Deputy Director, Regulatory Programs (or designee)
(Required before regulated activity can be started)

Date: 12/17/18

P.I.N. 1760.68

TURF ESTABLISHMENT - SEED MIX AS SPECIFIED

ITEM 610.16XXNN24 - TURF ESTABLISHMENT - SEED MIX AS SPECIFIED

610-1 Description			
-1.02 Establishing Turf			
Station to Station	Side	Quantity	Remarks
Contract Limits	Lt & Rt	272y ²	Establishing turf will be as shown on the plans, details, typical sections, tables, Contract Documents and as ordered by the Engineer. (A.O.B.E.).
Total square yard		272y ²	
610-2 Materials			
-2.02 Seeding Material			
Seeds:		713-04 and as indicated in detail specifications table	
Fertilizer		713-03 Type No. 3 (1-1-1, 50% N/FU)	
Mulch:		713-19 Straw	
Mulch Anchorage:		713-12 Mulch Anchorage, Type A	
610-3 Construction Details			
-3.02 A. Rates:			
Seed		See specific seed mix for rate.	
Fertilizer		90 grams of nitrogen / m ²	
Mulch:		Straw Mulch Only; 0.5 kg/m ² Firm seed bed prior to mulch	
Mulch Anchorage:		As per the manufacturer's recommendation	
Limestone:		3g/ 26.35 sm (25 lb/ 1000 sq. ft.)	
-3.02 D. Ground Preparation and Seeding:			
As per the Standard Specifications.			
Method No. 2 shall be used to establish turf in front of all areas near residential or commercial buildings			
Method No. 1 shall be used in all other areas.			
In those areas where topsoil is not specified, the areas to be seeded shall be scarified or tilled to a minimum depth of 150mm immediately before seeding, unless otherwise directed by the Engineer.			

FINAL
ADIRONDACK PARK AGENCY
FILE # 2018-0126

>>>DETAIL SPECIFICATIONS FOR SEEDS <<<
SEE BELOW

Seed Mix "A" – Native Roadside Seed Mix

A= Approx. % by Seed Count

Species	Variety	A
Virgina Wild Rye (<i>Elymus virginicus</i>)	Commercial	5.00%
Panicledleaf Tick Trefoil (<i>Desmodium paniculatum</i>)	Commercial	0.56%
Little Bluestem (<i>Schizachyrium scoparium</i>)	Commercial	11.67%
Big Bluestem (<i>Andropogon gerardii</i>)	Commercial	7.78%
Creeping Red Fescue (<i>Festuca rubra</i>)	Commercial	23.89%
Indian Grass (<i>Sorghastrum nutans</i>)	Commercial	7.78%
Switch Grass (<i>Panicum virgatum</i>)	Commercial	5.59%
Staghorn Sumac (<i>Rhus typhina</i>)	Commercial	0.56%
Grey Dogwood (<i>Cornus racemosa</i>)	Commercial	0.00%
Silky Dogwood (<i>Cornus amomum</i>)	Commercial	0.00%
Evening Primrose (<i>Oenothera biennis</i>)	Commercial	15.56%
Butterfly Milkweed (<i>Asclepias tuberosa</i>)	Commercial	0.56%

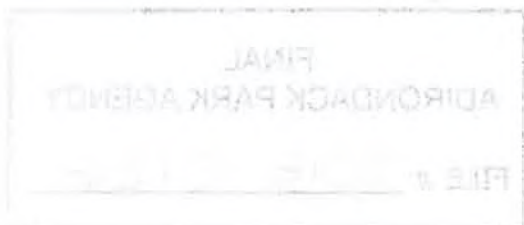

Black Eyed Susan (<i>Rudbeckia hirta</i>)	Commercial	13.89%
Partridge Pea (<i>Chamaecrista fasciculata</i>)	Commercial	0.56%
Hollow-Stem Joe Pye Weed (<i>Eupatorium fistulosum</i>) (<i>Eutrochium fistulosum</i>)	Commercial	6.67%

FINAL
ADIRONDACK PARK AGENCY
FILE # 2018-0126

(This page intentionally left blank)

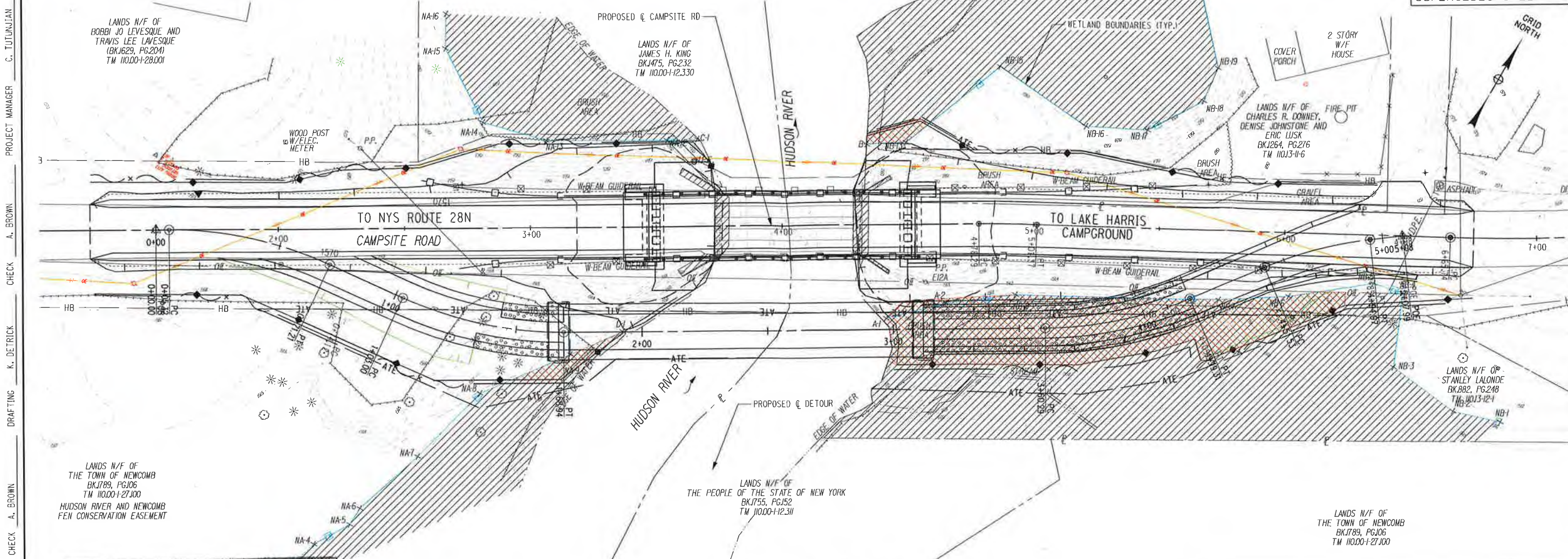

FINAL
ADIRONDACK PARK AGENCY
FILE # 2018-0126

- LEGEND:**
- TEMPORARY WETLAND IMPACTS
 - PERMANENT WETLANDS
 - APA REGULATED WETLAND
 - APA REGULATED WETLAND BOUNDARY
 - TEMPORARY PLASTIC FENCE
 - TEMPORARY SILT FENCE
 - APPROXIMATE FINAL FILL LINE
 - APPROXIMATE FINAL CUT LINE
 - TEMPORARY DETOUR FILL LINE
 - BRIDGE EXCAVATION LIMITS
 - WETLAND FLAG LOCATION AND IDENTIFICATION

- NOTES:**
- IN WETLAND LOCATIONS THAT REQUIRE EXCAVATION (SUCH AS EXCAVATION FOR THE PROPOSED DETOUR ABUTMENTS), CONTRACTOR SHALL REMOVE AND STOCKPILE TOP 12" OF EXISTING SOILS IN TEMPORARY WETLAND IMPACT AREA FOR LATER USE IN RESTORATION.
 - PRIOR TO PLACING THE GEOTEXTILE SEPARATION FOR THE DETOUR EMBANKMENT, THE EXISTING WETLAND PLANTS SHALL BE CUT FLUSH WITH THE GROUND.
 - WETLAND RESTORATION AREA SHALL BE REESTABLISHED PER SPECIAL SPECIFICATION 203.01920007. ALL WETLAND AREAS TO BE RESTORED SHALL BE SEEDED WITH WETLAND SEED MIX B ONLY AS SPECIFIED IN SPECIAL SPECIFICATION. NO SOD MIX WILL BE ALLOWED IN WETLAND AREAS.
 - ALL STOCKPILED WETLAND SOILS SHALL BE PROTECTED BY PERIMETER EROSION CONTROL MATERIALS AND PAID FOR UNDER ITEM 209.13, TEMPORARY SEDIMENT CONTROL FENCE.
 - SILT FENCE, ITEM 209.13, SHALL BE PLACED AROUND THE CONTRACTOR STAGING AREA.
 - AS SHOWN IN THE TYPICAL DETOUR SECTION ON DWG. ST-5, THE WETLAND AREA SHALL BE FLUSH CUT AND OVERLAIN WITH GEOTEXTILE SEPARATION, ITEM 207.21. SINCE WETLAND RESTORATION, ITEM 203.01920007, IS BASED ON A CUBIC YARD MEASUREMENT, THE PAYMENT TO THE CONTRACTOR SHALL BE BASED ON THE AREAS SHOWN ON THIS PLAN AND A DEPTH OF 1 FT IN ALL AREAS, INCLUDING WHERE EXCAVATION DOES NOT OCCUR.

- WETLAND RESTORATION/PROTECTION NOTES:**
- PRIOR TO THE START OF CLEARING AND GRUBBING AND/OR ANY CONSTRUCTION ADJACENT TO THE WETLANDS, THE ENGINEER-IN-CHARGE SHALL VERIFY THE LOCATION(S) OF THE AREA(S) TO BE PRESERVED, AND THE TREES TO BE SAVED. NO DISTURBANCE SHALL BE ALLOWED WITHIN THE BOUNDARIES OF THE WETLAND AREAS TO BE PRESERVED AS SHOWN ON THE PLANS AND AS DELINEATED WITH TEMPORARY PLASTIC BARRIER FENCE AND/OR SILT FENCE.
 - EROSION CONTROL MEASURES AS INDICATED ON THE PLANS SHALL BE PLACED AS CLOSE AS POSSIBLE TO THE EDGE OF THE EXISTING WETLANDS TO BE PRESERVED WITHOUT INTERFERING WITH GRADING OPERATIONS.
 - ALL TEMPORARY WETLAND IMPACT AREAS SHALL HAVE ALL VEGETATION FLUSH CUT TO EXISTING GRADE. A GEOTEXTILE SEPARATION BARRIER SHALL BE PLACED BETWEEN EXISTING GRADE AND TEMPORARY FILL. THESE AREAS SHALL BE SEEDED WITH WETLAND SEED MIX B UPON REMOVAL OF FILL AND GEOTEXTILE.
 - IN ORDER TO PROMOTE THE EARLY DEVELOPMENT OF PLANT MATERIAL WITHIN THE WETLANDS TO BE RECONSTRUCTED, THE CONTRACTOR SHALL RECONSTRUCT THE WETLAND AS EARLY IN THE CONSTRUCTION SEQUENCE AS POSSIBLE. IF RECONSTRUCTION OF THE WETLANDS IS DELAYED AT ANY TIME, AN APPROVED TEMPORARY EROSION CONTROL MEASURE SHALL BE APPLIED UNTIL RECONSTRUCTION IS CONTINUED.
 - PRIOR TO FINISH GRADING OF THE WETLAND AREAS, THE ENGINEER-IN-CHARGE SHALL BE NOTIFIED TO VERIFY THE FINAL SHAPE OF THE WETLAND AREA.
 - THE WETLAND RESTORATION SHALL BE SUPERVISED BY QUALIFIED PERSONNEL PROVIDED BY ESSEX COUNTY.

AREA	PERMANENT WETLAND IMPACTS	TEMPORARY WETLAND * IMPACTS	TEMPORARY FILL WETLAND * IMPACTS	TEMPORARY EXCAVATION WETLAND ** IMPACTS
SW	0.0 +/- SF 0.0 +/- AC.	190.0 +/- SF 0.0044 +/- AC.	178.3 +/- SF 0.0041 +/- AC.	11.7 +/- SF 0.0003 +/- AC.
NW	0.0 +/- SF 0.0 +/- AC.	0.0 +/- SF 0.0 +/- AC.	0.0 +/- SF 0.0 +/- AC.	0.0 +/- SF 0.0 +/- AC.
SE	0.0 +/- SF 0.0 +/- AC.	3940.6 +/- SF 0.0905 +/- AC.	2603.2 +/- SF 0.0598 +/- AC.	1337.4 +/- SF 0.0307 +/- AC.
NE	0.0 +/- SF 0.0 +/- AC.	130.0 +/- SF 0.0030 +/- AC.	130.0 +/- SF 0.0030 +/- AC.	0.0 +/- SF 0.0 +/- AC.
TOTAL	0.0 +/- SF 0.0 +/- AC.	4260.6 +/- SF 0.0979 +/- AC.	2911.5 +/- SF 0.0669 +/- AC.	1349.1 +/- SF 0.0310 +/- AC.

** TEMPORARY EXCAVATION OF WETLANDS REQUIRED AT TEMPORARY BRIDGE FOUNDATION AND CRSS WALL AREA.
* TEMPORARY FILL REQUIRED AT ALL IMPACTED AREAS.

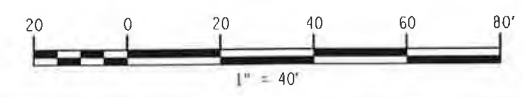

AS-BUILT REVISIONS DESCRIPTION OF ALTERATIONS:	CAMPSITE ROAD OVER HUDSON RIVER	PIN 1760.68	BRIDGES	CULVERTS	ALL DIMENSIONS IN FT UNLESS OTHERWISE NOTED	CONTRACT NUMBER
	BRIDGE REPLACEMENT PROJECT		BIN 3302040			
	TOWN OF NEWCOMB				WETLAND RESTORATION	DRAWING NO. ST-30
	COUNTY: ESSEX	REGION: 1				SHEET NO. 1 OF 6

IT IS A VIOLATION OF LAW FOR ANY PERSON, UNLESS THEY ARE ACTING UNDER THE DIRECTION OF A LICENSED PROFESSIONAL ENGINEER, ARCHITECT, LANDSCAPE ARCHITECT, OR LAND SURVEYOR, TO ALTER AN ITEM IN ANY WAY. IF AN ITEM BEARING THE STAMP OF A LICENSED PROFESSIONAL IS ALTERED, THE ALTERING ENGINEER, ARCHITECT, LANDSCAPE ARCHITECT, OR LAND SURVEYOR SHALL STAMP THE DOCUMENT AND INCLUDE THE NOTATION "ALTERED BY" FOLLOWED BY THEIR SIGNATURE, THE DATE OF SUCH ALTERATION, AND A SPECIFIC DESCRIPTION OF THE ALTERATION.



FILE NAME: N:\Projects\2017\117-650_Campsite\cadd\dwg\APP_Permit_Plan\117-650_cpb_wet_wet.gpd
 DATE/TIME: 11/2/2016 10:48:48 AM
 USER: JLB

PROJECT MANAGER: C. TUTUNJIAN
 CHECK: A. BROWN
 DRAFTING: K. DETRICK
 CHECK: A. BROWN
 DESIGN: L. SHORT
 JOB MANAGER: C. TUTUNJIAN
 DESIGN SUPERVISOR: C. TUTUNJIAN

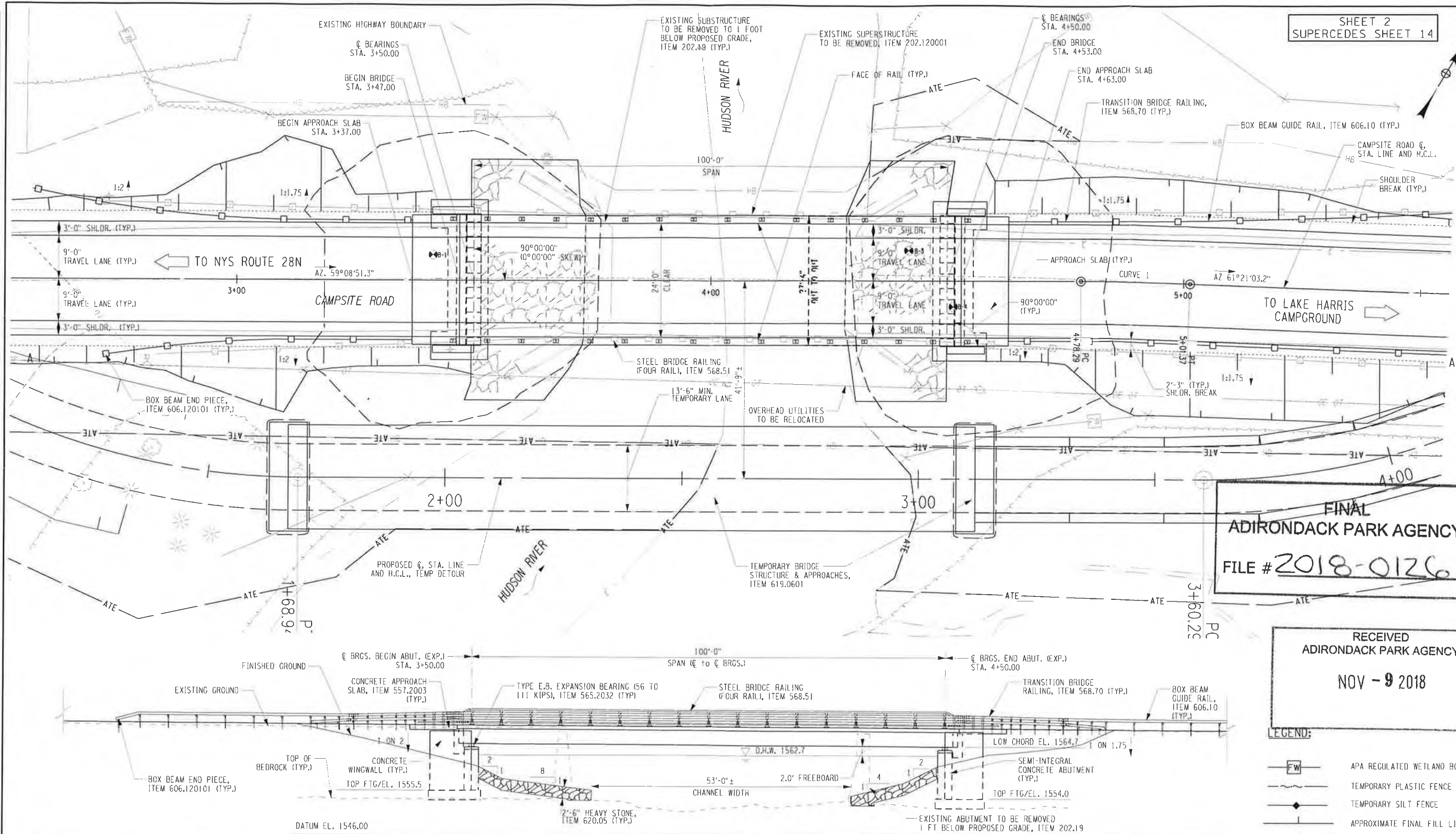

FINAL
ADIRONDACK PARK AGENCY
FILE # 2018-0126

RECEIVED
ADIRONDACK PARK AGENCY
NOV - 9 2018

- LEGEND:**
- APA REGULATED WETLAND BOUNDARY
 - TEMPORARY PLASTIC FENCE
 - TEMPORARY SILT FENCE
 - APPROXIMATE FINAL FILL LINE
 - APPROXIMATE FINAL CUT LINE
 - BORING LOCATION & DESIGNATION

HYDRAULIC DATA		BASE FLOOD	DESIGN FLOOD
DRAINAGE AREA = 116 SQ. MI.			
FREQUENCY INTERVALS (YEARS)		100	50
PEAK DISCHARGE (CFS)		7680	6780
HIGH WATER ELEV. (FT)		1563.4	1562.7
FREEBOARD PROVIDED (FT)	EXIST	0.1	0.8
	PROP.	1.8	2.5
AVG. VELOCITY @ STRUCTURE (FT/S)		9.92	8.85

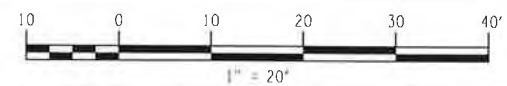

AS-BUILT REVISIONS	DESCRIPTION OF ALTERATIONS:	CAMPSITE ROAD OVER HUDSON RIVER	PIN 1760.68	BRIDGES	CULVERTS	ALL DIMENSIONS IN FT UNLESS OTHERWISE NOTED	CONTRACT NUMBER
		BRIDGE REPLACEMENT PROJECT		BIN 3302040		GENERAL PLAN & ELEVATION	DRAWING NO. ST-2
		TOWN OF NEWCOMB					SHEET NO. 2 OF 6
		COUNTY: ESSEX	REGION: 1				

IT IS A VIOLATION OF LAW FOR ANY PERSON, UNLESS THEY ARE ACTING UNDER THE DIRECTION OF A LICENSED PROFESSIONAL ENGINEER, ARCHITECT, LANDSCAPE ARCHITECT, OR LAND SURVEYOR, TO ALTER AN ITEM IN ANY WAY. IF AN ITEM BEARING THE STAMP OF A LICENSED PROFESSIONAL IS ALTERED, THE ALTERING ENGINEER, ARCHITECT, LANDSCAPE ARCHITECT, OR LAND SURVEYOR SHALL STAMP THE DOCUMENT AND INCLUDE THE NOTATION "ALTERED BY" FOLLOWED BY THEIR SIGNATURE, THE DATE OF SUCH ALTERATION, AND A SPECIFIC DESCRIPTION OF THE ALTERATION.

PROJECT MANAGER: C. TUTUNJIAN
 CHECK: A. BROWN
 K. DETRICK
 DRAWING: A. BROWN
 L. SHORT
 C. TUTUNJIAN
 C. TUTUNJIAN
 C. TUTUNJIAN

C. HUTTENBACH
PROJECT MANAGER
A. BROBIN
CHECK
R. BETHUNE
DRAWING
A. BROBIN
CHECK
L. SHURT
DESIGN
D. TUTTENBACH
JOB MANAGER

GENERAL NOTES:

LIVE LOAD: AASHTO HL-93
DESIGN SPECIFICATIONS: NYS DOT LRFD BRIDGE DESIGN SPECIFICATIONS WITH ALL PROVISIONS IN EFFECT AS OF DECEMBER 2018 (FOR DESIGN PURPOSES, COMPRESSIVE STRENGTH OF CONCRETE FOR SUBSTRUCTURES AND DECK SLABS AT 28 DAYS: $f'_c = 3000$ psi)
CONSTRUCTION AND MATERIAL SPECIFICATIONS, CONSTRUCTION AND MATERIALS, NEW YORK STATE DEPARTMENT OF TRANSPORTATION, OFFICE OF ENGINEERING, DATED JANUARY 1, 2019 WITH CURRENT ADDITIONS AND MODIFICATIONS.
ALL SHOP DRAWINGS SUBMITTED FOR THIS PROJECT SHALL BE IN ENGLISH UNITS. ERECTION DRAWINGS ARE TO BE PREPARED IN ENGLISH UNITS.
THE COST OF ALL JOINT MATERIAL SHALL BE INCLUDED IN THE UNIT PRICES BID FOR THE VARIOUS ITEMS OF THE CONTRACT, UNLESS OTHERWISE SPECIFIED ON THE PLANS.
THE TEMPORARY STRUCTURE SHALL BE DESIGNED IN ACCORDANCE WITH THE CURRENT NYS DOT LOAD AND RESISTANCE FACTOR (DESIGN LRFD) BRIDGE DESIGN SPECIFICATIONS FOR A DESIGN LIVE LOAD OF HL-93. ALTERNATIVELY, THE TEMPORARY STRUCTURE MAY BE DESIGNED IN CONFORMANCE WITH THE STANDARD SPECIFICATIONS FOR HIGHWAY BRIDGES FOR A DESIGN LOAD OF HS20.
THIS BRIDGE SHALL BE MAINTAINED IN ACCORDANCE WITH THE GUIDELINES CONTAINED IN THE CURRENT EDITION OF THE AASHTO MAINTENANCE MANUAL FOR ROADWAYS AND BRIDGES.
THE LOAD RATINGS ARE IN ACCORDANCE WITH THE AASHTO MANUAL FOR BRIDGE EVALUATION.

FOUNDATION NOTES:

ALL PLACEMENTS OF SELECT STRUCTURE FILL, ITEM 203.21, SHALL BE COMPACTED TO 95 PERCENT OF STANDARD PROCTOR MAXIMUM DENSITY.
HIGHWAY EMBANKMENT MATERIAL (FROM HIGHWAY ESTIMATE OR FROM STRUCTURE EXCAVATION BACKFILL) AND SELECT STRUCTURE FILL, ITEM 203.21, SHALL BE PLACED SIMULTANEOUSLY, IN CONTACT, ON BOTH SIDES OF THE VERTICAL PAYMENT LINE.
THE COST OF WATER USED FOR COMPACTION OF SELECT FILL ITEMS SHALL BE INCLUDED IN THE UNIT PRICE BID FOR ITEM 203.21 SELECT STRUCTURE FILL.

SUBSTRUCTURE NOTES:

TOP OF BACKWALLS SHALL BE SLEET TROWEL FINISHED. TWO SHEETS OF SHEET GASKET (TREATED BOTH SIDES), 12#-06, SHALL BE PLACED ON THE TOP OF THE BACKWALLS OF FIXED AND EXPANSION ABUTMENTS. PAYMENT SHALL BE INCLUDED IN THE UNIT PRICE BID FOR THE APPROACH SLAB ITEM.
THE PROVISIONS OF SECTION 555-3.11, CORRECTIVE FINISHING, WITH REGARD TO REMOVING RUST STAINS FROM CONCRETE EXPOSED TO VIEW ARE WAIVED. RUST STAINS SHALL NOT BE REMOVED FROM THE SUBSTRUCTURE ON THIS BRIDGE.
THE CONTRACTOR, WITH THE PERMISSION OF THE E.I.C., MAY ELECT TO INTRODUCE CONSTRUCTION JOINTS IN THE ABUTMENTS AT LOCATIONS NOT SHOWN ON THE PLANS. THESE CONSTRUCTION JOINTS SHALL BE PROVIDED WITH SHEAR KEYS AND WATERSTOPS. VERTICAL CONSTRUCTION JOINTS INTRODUCED IN THE BACKWALL SHOULD, PREFERABLY BE PLACED MIDWAY BETWEEN THE PEDESTALS.
THE COST OF ALL MATERIAL AT EACH CONSTRUCTION JOINT, CONSTRUCTION JOINT AND CONCRETE EXPANSION JOINT SHALL BE INCLUDED IN THE UNIT PRICES BID FOR THE VARIOUS ITEMS OF THE CONTRACT, UNLESS OTHERWISE SPECIFIED ON THE PLANS.

COFFERDAM AND PROTECTION NOTES:

IF THE CONTRACTOR ELECTS TO LAY BACK A PORTION OF THE EXCAVATION SHALL BE FINISHED TO THE EXISTING EARTH ADJACENT COFFERDAM NECESSARY TO KEEP AT NO COST TO THE STATE.
WHERE A COFFERDAM IS USED, THE COST OF DEWATERING THE ENTIRE EXCAVATION, REGARDLESS OF THE SOURCE OF WATER, SHALL BE INCLUDED IN THE UNIT PRICE BID FOR THE COFFERDAM ITEM.
DEWATERING OF THE COFFERDAM SHALL BE ACCOMPLISHED BY PUMPING THE WATER TO AN APPROVED UPLAND VEGETATED AREA OUTSIDE OF THE STREAM BED AS SHOWN ON THE PLANS AND/OR APPROVED BY THE E.I.C.
DEWATERING OF THE COFFERDAM SHALL BE ACCOMPLISHED BY PUMPING THE WATER TO AN APPROVED UPLAND VEGETATED AREA OUTSIDE OF THE STREAM BED AS SHOWN ON THE PLANS AND/OR APPROVED BY THE E.I.C.
THE CONTRACTOR SHALL ESTABLISH ALL RIGHT-OF-WAY AND EASEMENT LIMITS IN ACCORDANCE WITH ITEM 625.01 SURVEY OPERATIONS. THE RIGHT-OF-WAY AND EASEMENT BOUNDARY POINTS SHALL BE MAINTAINED THROUGHOUT THE DURATION OF CONSTRUCTION.
HORIZONTAL COORDINATES AND ELEVATIONS ARE REPORTED IN SURVEY FEET ON AN ASSUMED COORDINATE SYSTEM.

SURVEY:

THE CONTRACTOR SHALL ESTABLISH ALL RIGHT-OF-WAY AND EASEMENT LIMITS IN ACCORDANCE WITH ITEM 625.01 SURVEY OPERATIONS. THE RIGHT-OF-WAY AND EASEMENT BOUNDARY POINTS SHALL BE MAINTAINED THROUGHOUT THE DURATION OF CONSTRUCTION.
HORIZONTAL COORDINATES AND ELEVATIONS ARE REPORTED IN SURVEY FEET ON AN ASSUMED COORDINATE SYSTEM.

UPON COMPLETION AND ACCEPTANCE OF THIS CONTRACT, THE HIGHWAY AND BRIDGE WILL BE MAINTAINED BY THE STATE DEPARTMENT OF TRANSPORTATION PRIOR TO THIS CONTRACT.

CONTROL OF INVASIVE SPECIES NOTES:

CONTROLLER SPRINGS WOODPECKER AND BARN SWALLOW SHALL BE NATIVE TO NON-WOODS STATE. SEED ED CANARY-GRASS SHALL BE PLACED ON THE PROJECT SITE.
CONTRACTOR SHALL BE RESPONSIBLE FOR MONITORING AND REMOVING INVASIVE SPECIES FROM THE PROJECT SITE. SEED ED CANARY-GRASS SHALL BE PLACED ON THE PROJECT SITE.
SPILLS SHALL BE REPORTED AS REQUIRED BY REGULATION.
ALL WASTE MATERIAL (RUBBLE, SAND BLASTING AND CHIPPING WASTES AND RESIDUES, ETC.) RESULTING FROM CONSTRUCTION MUST BE COLLECTED AND MOVED TO AN APPROVED DISPOSAL AREA. NO MATERIAL SHALL BE ALLOWED TO ENTER EITHER DIRECTLY OR INDIRECTLY INTO ANY STREAM OR ANY FRESHWATER WETLAND.
ALL DISTURBED PORTIONS OF THE WORK AREA AND STREAM BANKS MUST BE GRADED TO EITHER RIP-RAPPED OR PLANTED WITH SUITABLE GRASSES, SHRUBS OR LEGUMES, AND/OR CONSERVATION TYPE GRASS MIXTURE AND MULCHES. MULCH SHALL BE MAINTAINED UNTIL COVER HAS BEEN ESTABLISHED. LIME AND FERTILIZER SHALL BE USED AS REQUIRED.

DISPOSAL OF CONSTRUCTION AND DEMOLITION DEBRIS:

THERE ARE NO AREAS WITHIN THE CONTRACT LIMITS AVAILABLE FOR DISPOSAL OF DEBRIS. THE CONTRACTOR SHALL USE CARE SO AS NOT TO REMOVE OR DAMAGE EXISTING TREES THAT ARE NOTED TO BE REMOVED OR DAMAGED. TREES BEYOND THE LIMITS OF WORK SHOULD REMOVAL OR DAMAGE OCCUR TO ANY TREE, THE CONTRACTOR SHALL BE RESPONSIBLE FOR REPLACING OR MAINTAINING THEM TO REMAIN. THEY SHALL BE REPLACED IN KIND BY THE CONTRACTOR, AT NO ADDITIONAL COST TO THE COUNTY.

SUPERSTRUCTURE NOTES:

ALL STRUCTURAL STEEL SHALL CONFORM TO ASTM A709 GRADE 50.
A. IN THE FABRICATION SHOP, GUIDES SHALL BE USED TO CONTROL DIMENSIONS AND TO PREVENT DISTORTION OF THE STEEL. ALL DIMENSIONS SHALL BE MEASURED TO THE CENTERLINE OF THE MEMBER.
B. FABRICATION SHOP, THE CONTRACTOR SHALL BE RESPONSIBLE FOR MONITORING AND REMOVING INVASIVE SPECIES FROM THE PROJECT SITE. SEED ED CANARY-GRASS SHALL BE PLACED ON THE PROJECT SITE.
THE CONTRACTOR SHALL BE RESPONSIBLE FOR MONITORING AND REMOVING INVASIVE SPECIES FROM THE PROJECT SITE. SEED ED CANARY-GRASS SHALL BE PLACED ON THE PROJECT SITE.

SUPERSTRUCTURE NOTES CONT'D:

DIAPHRAGMS SHALL BE FABRICATED TO FIT GIRDERS ERECTED WITH THEIR WEBS PLUMB FOR THE STEEL DEAD LOAD CONDITION, ALSO KNOWN AS STEEL DEAD LOAD FIT (SDFL).
STEEL ERECTION NOTES:
DESIGN OF THIS STRUCTURE ASSUMES THAT THE STRUCTURAL STEEL IS TO BE ERECTED IN ACCORDANCE WITH THE AISC MANUAL.
DESIGN OF THIS STRUCTURE ASSUMES THAT THE STRUCTURAL STEEL IS TO BE ERECTED IN ACCORDANCE WITH THE AISC MANUAL.
DESIGN OF THIS STRUCTURE ASSUMES THAT THE STRUCTURAL STEEL IS TO BE ERECTED IN ACCORDANCE WITH THE AISC MANUAL.

SUPERSTRUCTURE SLAB NOTES:

THE CONTRACTOR'S ATTENTION IS DIRECTED TO THE PROVISIONS OF THE CURRENT SPECIFICATIONS FOR SUPERSTRUCTURE SLABS, WHICH ALLOW THE OPTION OF 3 FORMING SYSTEMS FOR THE UNDERSIDE OF THE METAL AND REMOVABLE WOODEN FORMS.
NO DEVIATIONS FROM THE MAUNCH DETAILS SHOWN ON THESE PLANS MAY BE MADE WITHOUT THE PERMISSION OF THE E.I.C.
TOP SURFACES OF NEW BRIDGE DECKS AND APPROACH SLABS SHALL BE SEALED ACCORDING TO ITEM 203.02.18. THE CONTRACTOR SHALL BE RESPONSIBLE FOR MONITORING AND REMOVING INVASIVE SPECIES FROM THE PROJECT SITE. SEED ED CANARY-GRASS SHALL BE PLACED ON THE PROJECT SITE.

THE CONTRACTOR'S ATTENTION IS DIRECTED TO THE FACT THAT, DUE TO THE NATURE OF RECONSTRUCTION PROJECTS, THE EXACT FIELD CONDITIONS MAY REQUIRE MODIFICATIONS TO CONSTRUCTION DETAILS AND WORK QUANTITIES. THE CONTRACTOR SHALL PERFORM WORK IN ACCORDANCE WITH FIELD CONDITIONS.
THE CONTRACTOR SHALL BE RESPONSIBLE FOR MONITORING AND REMOVING INVASIVE SPECIES FROM THE PROJECT SITE. SEED ED CANARY-GRASS SHALL BE PLACED ON THE PROJECT SITE.

WHENEVER WORK UNDER THE CONTRACT REQUIRES MATERIALS TO BE REMOVED AND DISPOSED OF, THE COST OF SUPPLYING A DISPOSAL AREA AND TRANSPORTATION TO THAT AREA SHALL BE INCLUDED IN THE UNIT PRICES BID FOR THOSE ITEMS.
DURING THE AREA OF CONSTRUCTION, THE CONTRACTOR SHALL NOT BE ALLOWED TO DROP WASTE CONCRETE, DEBRIS AND OTHER MATERIAL TO THE AREA OF CONSTRUCTION OR BRIDGE EXCEPT WHERE THE PLANS SPECIFICALLY PERMIT THE DROPPING OF MATERIAL. PLATFORMS, NETS, SCREENS OR OTHER DEVICES SHALL BE USED TO CATCH THE MATERIAL. IF THE ENGINEER DETERMINES THAT ADEQUATE PROTECTIVE DEVICES ARE NOT BEING EMPLOYED, THE WORK SHALL BE SUSPENDED UNTIL ADEQUATE PROTECTION IS PROVIDED.
ALL MATERIAL FALLING ON THE AREA BELOW AND ADJACENT TO THE BRIDGE SHALL BE REMOVED AND DISPOSED OF BY THE CONTRACTOR AT NO COST TO THE COUNTY.
THE COST OF FURNISHING, INSTALLING, MAINTAINING, REMOVING AND DISPOSING OF ALL PLATFORMS, NETS, SCREENS OR OTHER PROTECTIVE DEVICES SHALL BE INCLUDED IN THE UNIT PRICES BID FOR THE APPROPRIATE ITEMS OF THE CONTRACT.

STREAM PROTECTION NOTES:

STREAM PROTECTION SHALL BE PROVIDED DURING THE PERIOD BETWEEN JUNE 15 AND SEPTEMBER 30. COFFERDAMS IN THE STREAM CHANNELS SHALL BE DESIGNED AND CONSTRUCTED TO ALLOW THE FLOW OF WATER TO PASS THROUGH THEM WITHOUT PROMPTER SPECIAL PERMITS FROM THE NEW YORK STATE DEPARTMENT OF ENVIRONMENTAL CONSERVATION. COFFERDAMS AND STREAM DIVERSIONS SHALL BE SIZED WITH REGARD TO THE SEASONAL FLOW OF THE STREAM EXPECTED FOR THE TIME THEY ARE TO BE IN USE.
ALL WORK SHALL BE DONE IN ACCORDANCE WITH THE REQUIREMENTS OF THE APA ACODE PERMIT XXX-NAN-XXX-XXX AND THE NYSDEC GENERAL PERMIT FOR CONSTRUCTION OF STREAM PROTECTION.
DURING MINIMUM EQUIPMENT COST 0 ANY SERIALS SHALL CONDUCT OPERATIONS IN SUCH A MANNER AS TO PREVENT OR REDUCE TO A DEBRIS, SEDIMENT, OR OTHER FOREIGN MATERIAL, OR FROM MANIPULATION OF

AS-BUILT REVISIONS DESCRIPTION OF ALTERATIONS:	CAMPBELL ROAD OVER HUDSON RIVER BRIDGE REPLACEMENT PROJECT TOWN OF NEWCOMB REGION: I	PIN 1760.68	BIN BRIDGES 3302040	CULVERTS	ALL DIMENSIONS IN FT UNLESS OTHERWISE NOTED	CONTRACT NUMBER
	COUNTY: ESSEX					
IT IS A VIOLATION OF LAW FOR ANY PERSON UNLESS THEY ARE ACTING UNDER THE DIRECTION OF A LICENSED PROFESSIONAL ENGINEER, ARCHITECT, LANDSCAPE ARCHITECT, OR LAND SURVEYOR TO ALTER AN ITEM IN ANY WAY. IF AN ITEM BEARING THE STAMP OF A LICENSED PROFESSIONAL IS ALTERED, THE ALTERING ENGINEER, ARCHITECT, LANDSCAPE ARCHITECT, OR LAND SURVEYOR SHALL STAMP THE DOCUMENT AND INCLUDE THE NOTATION "ALTERED BY" FOLLOWED BY THEIR SIGNATURE, THE DATE OF SUCH ALTERATION, AND A SPECIFIC DESCRIPTION OF THE ALTERATION.						

ADIRONDACK FINAL
K PARK AGENCY

FILE # 2018-0126

NEW YORK STATE DEPARTMENT OF ENVIRONMENTAL CONSERVATION

Division of Environmental Permits, Region 5
1115 State Route 86, PO Box 296, Ray Brook, NY 12977-0296
P: (518) 897-1234 | F: (518) 897-1394
www.dec.ny.gov

February 6, 2019

Essex County DPW
Attn: Chris Garrow
8065 NYS RTE 9
Elizabethtown, NY 12932

Re: Campsite Road Bridge
DEC #5-1538-00034/00004
Newcomb (T) Essex County

Dear Mr. Garrow:

Enclosed is your permit which was issued in accordance with the applicable provisions of the Environmental Conservation Law. Questions regarding the terms of the permit should be directed to Thomas Shanahan at (518) 897-1291. Should your plans change, please contact this office to determine whether modifications of the permit are required.

Please note that it is the responsibility of the permittee and his agents to read and comply with all permit conditions. Carefully review the project sketches attached to this permit. Minor changes may have been made in the location or dimensions of your project, or additional materials (i.e. filter fabric or rock rip-rap) may have been included in the plans. Further, the permit is valid only for the activity expressly authorized. Work beyond the scope of the permit shall be considered as work without a permit. Any failure to comply with these terms may be treated as a violation of the Environmental Conservation Law. Work done under this permit is subject to inspection by Forest Rangers and Environmental Conservation Officers.

This permit does not eliminate the need to obtain approvals from other local or state agencies, or from the U.S. Army Corps of Engineers (USACOE). If your project is located within the Adirondack Park, approvals may be required from the Adirondack Park Agency (APA).

Sincerely,



Erin L. Burns
Deputy Regional Permit Administrator

cc: Thomas Shanahan, DEC
USACOE, NAN-2018-01542-UPO
Devan Korn, APA 2018-0126
Alex Brown, Creighton Manning
Joan Ducharme, OPP
ECO Lt. Mike Phelps



Department of
Environmental
Conservation



PERMIT
Under the Environmental Conservation Law (ECL)

Permittee and Facility Information

Permit Issued To:
ESSEX COUNTY

7551 COURT ST

PO BOX 217
ELIZABETHTOWN, NY 12932-0217
(518) 873-3353

Facility:

CAMPSITE RD BRIDGE OVER HUDSON
RIVER
CAMPSITE RD OVER HUDSON RIVER\N OF
ST RTE 28N
NEWCOMB, NY 12852

Facility Location: in NEWCOMB in ESSEX COUNTY

Facility Principal Reference Point: NYTM-E: 570.929 NYTM-N: 4868.808
Latitude: 43°58'08.3" Longitude: 74°06'56.8"

Authorized Activity: Removal of existing 58' bridge and replacement with an approximately 100' span bridge over the Hudson River. Rip rap will be placed in the stream as scour protection along the new abutments. All work shall be done in accordance with approved plans attached to and made part of this permit.

Permit Authorizations

Excavation & Fill in Navigable Waters - Under Article 15, Title 5

Permit ID 5-1538-00034/00004

New Permit Effective Date: 2/6/2019 Expiration Date: 10/1/2021

Water Quality Certification - Under Section 401 - Clean Water Act

Permit ID 5-1538-00034/00005

New Permit Effective Date: 2/6/2019 Expiration Date: 10/1/2021

Stream Disturbance - Under Article 15, Title 5

Permit ID 5-1538-00034/00006

New Permit Effective Date: 2/6/2019 Expiration Date: 10/1/2021



NYSDEC Approval

By acceptance of this permit, the permittee agrees that the permit is contingent upon strict compliance with the ECL, all applicable regulations, and all conditions included as part of this permit.

Permit Administrator: ERIN L BURNS, Deputy Regional Permit Administrator
Address: NYSDEC Region 5 Headquarters
1115 NYS ROUTE 86
PO BOX 296
RAY BROOK, NY 12977 -0296

Authorized Signature: Erin L. Burns Date 2/6/19

Permit Components

- NATURAL RESOURCE PERMIT CONDITIONS
- WATER QUALITY CERTIFICATION SPECIFIC CONDITION
- GENERAL CONDITIONS, APPLY TO ALL AUTHORIZED PERMITS
- NOTIFICATION OF OTHER PERMITTEE OBLIGATIONS

NATURAL RESOURCE PERMIT CONDITIONS - Apply to the Following Permits: EXCAVATION & FILL IN NAVIGABLE WATERS; WATER QUALITY CERTIFICATION; STREAM DISTURBANCE

- 1. Contact DEC If Permit Is Unclear** If any portion of this permit is unclear or should you have any questions about the special permit conditions incorporated in this permit, please contact the Division of Environmental Permits. Calls can be made on weekdays (excluding holidays) between 8:30 a.m. and 4:30 p.m.
- 2. Floodplain Regulations** The project must meet all local and federal floodplain regulations and, if applicable, a written approval from the floodplain administrator must be kept on file.
- 3. Other Agency Approvals** This permit does not eliminate the need to obtain approvals from other local, state or federal agencies such as the Adirondack Park Agency (APA) for projects located within the Adirondack Park, the Lake George Park Commission (LGPC) for projects located in Lake George Park, the Hudson River-Black River Regulating District (HRBRRD) for projects located on Great Sacandaga Lake or the U.S. Army Corps of Engineers (USACE) for projects which are located in federal waters or wetlands.



4. Prohibition Period for Trout All instream work, as well as any work that may result in the suspension of sediment, is prohibited during the trout spawning and incubation period commencing October 1 and ending April 30, unless project-specific authorization is granted.

5. Conformance With Plans All activities authorized by this permit must be in strict conformance with the approved plans submitted by the applicant or applicant's agent as part of the permit application. Such approved plans were prepared by Creighton Manning, received by the DEC on November 19, 2018 and January 7, 2019.

6. Notice of Intent to Commence Work The permittee shall submit a Notice of Intent to Commence Work to 48 at least Bureau of Fisheries hours in advance of the time of commencement and shall also notify them promptly in writing of the completion of work.

7. Post Permit Sign The permit sign enclosed with this permit shall be posted in a conspicuous location on the worksite and adequately protected from the weather.

WATER QUALITY

8. Precautions Against Contamination of Waters All necessary precautions shall be taken to preclude contamination of any wetland or waterway by suspended solids, sediments, fuels, solvents, lubricants, epoxy coatings, paints, concrete, leachate or any other environmentally deleterious materials associated with the project.

9. No Equipment in the Water Heavy equipment operation in the water is prohibited. With backhoes and similar heavy equipment, the bucket may enter the water.

10. Concrete Leachate During construction, no wet or fresh concrete or leachate shall be allowed to escape into any wetlands or waters of New York State, nor shall washings from ready-mixed concrete trucks, mixers, or other devices be allowed to enter any wetland or waters. Only watertight or waterproof forms shall be used. Wet concrete shall not be poured to displace water within the forms.

11. No Interference With Navigation There shall be no unreasonable interference with navigation by the work herein authorized.

12. Maintain Water Flow During Work During periods of work activity, flow immediately downstream of the work site shall equal flow immediately upstream of the work site.

13. Turbid Discharges Visibly turbid discharges from land clearing, grading or excavation activities, or de-watering operations shall not enter the stream, navigable water, or wetland. Prior to entry into stream, navigable water or wetland, any such discharge shall be:

- a. retained in an appropriately maintained upland settling basin;
- b. filtered through crushed stone, sand, straw bales, silt screening (maximum opening size of U.S. Sieve Number 20), etc.; or,
- c. directed to a grassy upland area a sufficient distance from the stream to prevent change in turbidity of the receiving water.

A handwritten signature in black ink, appearing to be 'EJB', located at the bottom right of the page.



EROSION CONTROLS

- 14. Siltation Prevention Measures** Siltation prevention measures, such as silt fencing, sediment traps or settling basins, shall be installed and maintained during the project, to prevent movement of silt and turbid waters from the project site into any watercourse, stream, water body or wetland.
- 15. Clearing of Vegetation** Clearing of natural vegetation shall be limited to that material which poses a hazard or a hindrance to the construction activity.
- 16. Install and Maintain Erosion Controls** Staked hay or straw bales or other DEC-approved erosion control measures are to be installed on the downslope edge of any disturbed areas. This barrier to sediments is to be put in place before any disturbance of the ground occurs and is to be maintained in a functional condition until all disturbed land is heavily vegetated.
- 17. Materials Removed from Bed and Banks** Any debris or excess materials from construction of this project shall be immediately and completely removed from the bed and banks of all water areas to an appropriate upland area for disposal.
- 18. Seed, Mulch Disturbed Areas** All areas of soil disturbance resulting from this project shall be seeded with an appropriate perennial grass, and mulched with straw immediately upon completion of the project, within two days of final grading, or by the expiration of the permit, whichever is first.
- 19. Temporary Mulch, Final Seeding** If seeding is impracticable due to the time of year, a temporary mulch shall be applied and final seeding shall be performed at the earliest opportunity when weather conditions favor germination and growth but not more than six months after project completion.

PRE-CONSTRUCTION REQUIREMENTS

- 20. Filter Fabric Curtain Around Work Area** A filter fabric (turbidity) curtain weighted across the bottom and suspended at the top by floats shall be positioned to enclose the work site before commencing operations. The curtain shall remain in place and in functional condition during all phases of the operations and remain in place until turbidity inside the curtain no longer exceeds ambient levels.
- 21. Sandbags** Sandbags shall be of the filter fabric type, double bagged and individually tied to prevent sand leakage. They shall be placed and removed manually to prevent spillage. Only clean sand, free of debris, silt, fine particles, or other foreign substances shall be used to fill the bags. All bags shall be filled at an upland site where spillage will not enter the water, and all sand stored on-site shall be surrounded by straw bales or covered with a tarp to prevent erosion of the sand into the water.
- 22. Dewatering Within Cofferdam** Dewatering within the coffer(s) shall be performed so as to minimize siltation and turbidity. Water taken from the coffered area will be passed through settling basins, filter material or other accepted devices to prevent the discharge of turbid water into the receiving waterbody. All fish trapped within the cofferdam during the dewatering process shall be returned, alive and unharmed, to the water outside the confines of the cofferdam.
- 23. Settling of Sediments Within Cofferdam** The cofferdam shall remain in place until the water clarity in the coffered area matches the open water.



CONSTRUCTION REQUIREMENTS

- 24. Clean Fill Only** All fill shall consist of clean soil, sand and/or gravel that is free of the following substances: asphalt, slag, flyash, broken concrete, demolition debris, garbage, household refuse, tires, woody materials including tree or landscape debris, and metal objects. The introduction of materials toxic to aquatic life is expressly prohibited.
- 25. No Rock From Stream/Lake** No rock for use in construction is to come from the stream or lake bed.
- 26. Contain Backfill Behind Breakwall** Material used as backfill shall be sized to prevent the escape of such material from any openings in the breakwall. A non-biodegradable ground stabilization fabric or filter fabric may be employed to provide containment for such backfill material.
- 27. Installation of Riprap** The stone riprap (revetment) installed must contain no more than one cubic yard of rock per running foot below mean high water. The revetment shall be placed on a layer of filter material such as gravel, small rock and/or woven filter cloth to provide positive drainage and better stability. The revetment toe stone must be keyed to a depth of at least one foot below the soil/waterbody interface, below the Mean High Water Elevation or be adequately fixed to bedrock. The face of the revetment must be sloped no steeper than one foot vertical to one and one-half feet horizontal (1:1.5).
- 28. Consolidation of Armor Stone Prohibited** Armor stone may not be consolidated with concrete or by any other means.
- 29. Maintain Channel Geometry** The stream channel bed width, depth and bank height immediately upstream and downstream of the project site shall be consistent with the average channel bed width of the stream. There shall be no widening or constriction of the stream channel bed through the road crossing, and no berms shall be constructed on the stream or river banks.
- 30. Temporary Crossing to Be Removed and Restored** Immediately following project completion or by the expiration of the permit, whichever comes first, any temporary crossing is to be completely removed, and the stream bed and banks are to be returned to pre- project conditions and are to be stabilized by seeding and mulching with straw.

AREA RESTRICTIONS

- 31. State May Require Site Restoration** If upon the expiration or revocation of this permit, the project hereby authorized has not been completed, the applicant shall, without expense to the State, and to such extent and in such time and manner as the Department of Environmental Conservation may lawfully require, remove all or any portion of the uncompleted structure or fill and restore the site to its former condition. No claim shall be made against the State of New York on account of any such removal or alteration.

ESB



32. State May Order Removal or Alteration of Work If future operations by the State of New York require an alteration in the position of the structure or work herein authorized, or if, in the opinion of the Department of Environmental Conservation it shall cause unreasonable obstruction to the free navigation of said waters or flood flows or endanger the health, safety or welfare of the people of the State, or cause loss or destruction of the natural resources of the State, the owner may be ordered by the Department to remove or alter the structural work, obstructions, or hazards caused thereby without expense to the State, and if, upon the expiration or revocation of this permit, the structure, fill, excavation, or other modification of the watercourse hereby authorized shall not be completed, the owners, shall, without expense to the State, and to such extent and in such time and manner as the Department of Environmental Conservation may require, remove all or any portion of the uncompleted structure or fill and restore to its former condition the navigable and flood capacity of the watercourse. No claim shall be made against the State of New York on account of any such removal or alteration.

33. State Not Liable for Damage The State of New York shall in no case be liable for any damage or injury to the structure or work herein authorized which may be caused by or result from future operations undertaken by the State for the conservation or improvement of navigation, or for other purposes, and no claim or right to compensation shall accrue from any such damage.

WATER QUALITY CERTIFICATION SPECIFIC CONDITIONS

1. Water Quality Certification The authorized project, as conditioned pursuant to the Certificate, complies with Section 301, 302, 303, 306, and 307 of the Federal Water Pollution Control Act, as amended and as implemented by the limitations, standards, and criteria of state statutory and regulatory requirements set forth in 6 NYCRR Section 608.9(a). The authorized project, as conditioned, will also comply with applicable New York State water quality standards, including but not limited to effluent limitations, best usages and thermal discharge criteria, as applicable, as set forth in 6 NYCRR Parts 701, 702, 703, and 704.

GENERAL CONDITIONS - Apply to ALL Authorized Permits:

1. Facility Inspection by The Department The permitted site or facility, including relevant records, is subject to inspection at reasonable hours and intervals by an authorized representative of the Department of Environmental Conservation (the Department) to determine whether the permittee is complying with this permit and the ECL. Such representative may order the work suspended pursuant to ECL 71- 0301 and SAPA 401(3).

The permittee shall provide a person to accompany the Department's representative during an inspection to the permit area when requested by the Department.

A copy of this permit, including all referenced maps, drawings and special conditions, must be available for inspection by the Department at all times at the project site or facility. Failure to produce a copy of the permit upon request by a Department representative is a violation of this permit.

EJB



2. Relationship of this Permit to Other Department Orders and Determinations Unless expressly provided for by the Department, issuance of this permit does not modify, supersede or rescind any order or determination previously issued by the Department or any of the terms, conditions or requirements contained in such order or determination.

3. Applications For Permit Renewals, Modifications or Transfers The permittee must submit a separate written application to the Department for permit renewal, modification or transfer of this permit. Such application must include any forms or supplemental information the Department requires. Any renewal, modification or transfer granted by the Department must be in writing. Submission of applications for permit renewal, modification or transfer are to be submitted to:

Regional Permit Administrator
NYSDEC Region 5 Headquarters
1115 NYS ROUTE 86
PO BOX 296
RAY BROOK, NY 12977 -0296

4. Submission of Renewal Application The permittee must submit a renewal application at least 30 days before permit expiration for the following permit authorizations: Excavation & Fill in Navigable Waters, Stream Disturbance, Water Quality Certification.

5. Permit Modifications, Suspensions and Revocations by the Department The Department reserves the right to exercise all available authority to modify, suspend or revoke this permit. The grounds for modification, suspension or revocation include:

- a. materially false or inaccurate statements in the permit application or supporting papers;
- b. failure by the permittee to comply with any terms or conditions of the permit;
- c. exceeding the scope of the project as described in the permit application;
- d. newly discovered material information or a material change in environmental conditions, relevant technology or applicable law or regulations since the issuance of the existing permit;
- e. noncompliance with previously issued permit conditions, orders of the commissioner, any provisions of the Environmental Conservation Law or regulations of the Department related to the permitted activity.

6. Permit Transfer Permits are transferrable unless specifically prohibited by statute, regulation or another permit condition. Applications for permit transfer should be submitted prior to actual transfer of ownership.



NOTIFICATION OF OTHER PERMITTEE OBLIGATIONS

Item A: Permittee Accepts Legal Responsibility and Agrees to Indemnification

The permittee, excepting state or federal agencies, expressly agrees to indemnify and hold harmless the Department of Environmental Conservation of the State of New York, its representatives, employees, and agents ("DEC") for all claims, suits, actions, and damages, to the extent attributable to the permittee's acts or omissions in connection with the permittee's undertaking of activities in connection with, or operation and maintenance of, the facility or facilities authorized by the permit whether in compliance or not in compliance with the terms and conditions of the permit. This indemnification does not extend to any claims, suits, actions, or damages to the extent attributable to DEC's own negligent or intentional acts or omissions, or to any claims, suits, or actions naming the DEC and arising under Article 78 of the New York Civil Practice Laws and Rules or any citizen suit or civil rights provision under federal or state laws.

Item B: Permittee's Contractors to Comply with Permit

The permittee is responsible for informing its independent contractors, employees, agents and assigns of their responsibility to comply with this permit, including all special conditions while acting as the permittee's agent with respect to the permitted activities, and such persons shall be subject to the same sanctions for violations of the Environmental Conservation Law as those prescribed for the permittee.

Item C: Permittee Responsible for Obtaining Other Required Permits

The permittee is responsible for obtaining any other permits, approvals, lands, easements and rights-of-way that may be required to carry out the activities that are authorized by this permit.

Item D: No Right to Trespass or Interfere with Riparian Rights

This permit does not convey to the permittee any right to trespass upon the lands or interfere with the riparian rights of others in order to perform the permitted work nor does it authorize the impairment of any rights, title, or interest in real or personal property held or vested in a person not a party to the permit.

New York State
Department of Environmental Conservation

 NOTICE 

The Department of Environmental Conservation (DEC) has issued permit(s) pursuant to the Environmental Conservation Law for work being conducted at this site. For further information regarding the nature and extent of work approved and any Departmental conditions on it, contact the Regional Permit Administrator listed below. Please refer to the permit number shown when contacting the DEC.

Regional Permit Administrator

Permit Number 5-1538-00034/00004

Expiration Date October 1, 2021

Erin L. Burns
Deputy Regional Permit Administrator

NOTE: This notice is NOT a permit



NOTICE OF INTENT TO INITIATE PROJECT CONSTRUCTION

NOTE: This notice must be mailed or faxed to the appropriate Department of Environmental Conservation Office listed below. Notice must be received by the Department at least 48 hours prior to initiation of construction activities.

The following information is to be filled out by DEC:

DEC Permit #: 5-1538-00034/00004
Permittee Name: Essex County
Address: 7551 Court Street
Elizabethtown, NY 12932

Telephone Number: (518) 873-3353

The following information must be completed by the Permittee:

I plan on initiating work on my project on _____
month/day/year

My contractor is: _____

Address: _____

Telephone: _____

Please mail or FAX this form prior to initiating project to:

NYSDEC
Natural Resources Office
PO Box 296, Route 86
Ray Brook, NY 12977-0296
(518) 897-1291
(518) 897-1370 FAX

NYSDEC
Natural Resources Office
232 Golf Course Road
Warrensburg, NY 12885-0220
(518) 623-1240
(518) 623-3603 FAX

PROJECT MANAGER: C. TUTUNJIAN
 CHECK: A. BROWN
 DRAINING: K. DETRICK
 CHECK: A. BROWN
 DESIGN: L. SHORT
 JOB MANAGER: C. TUTUNJIAN
 DESIGN SUPERVISOR: C. TUTUNJIAN

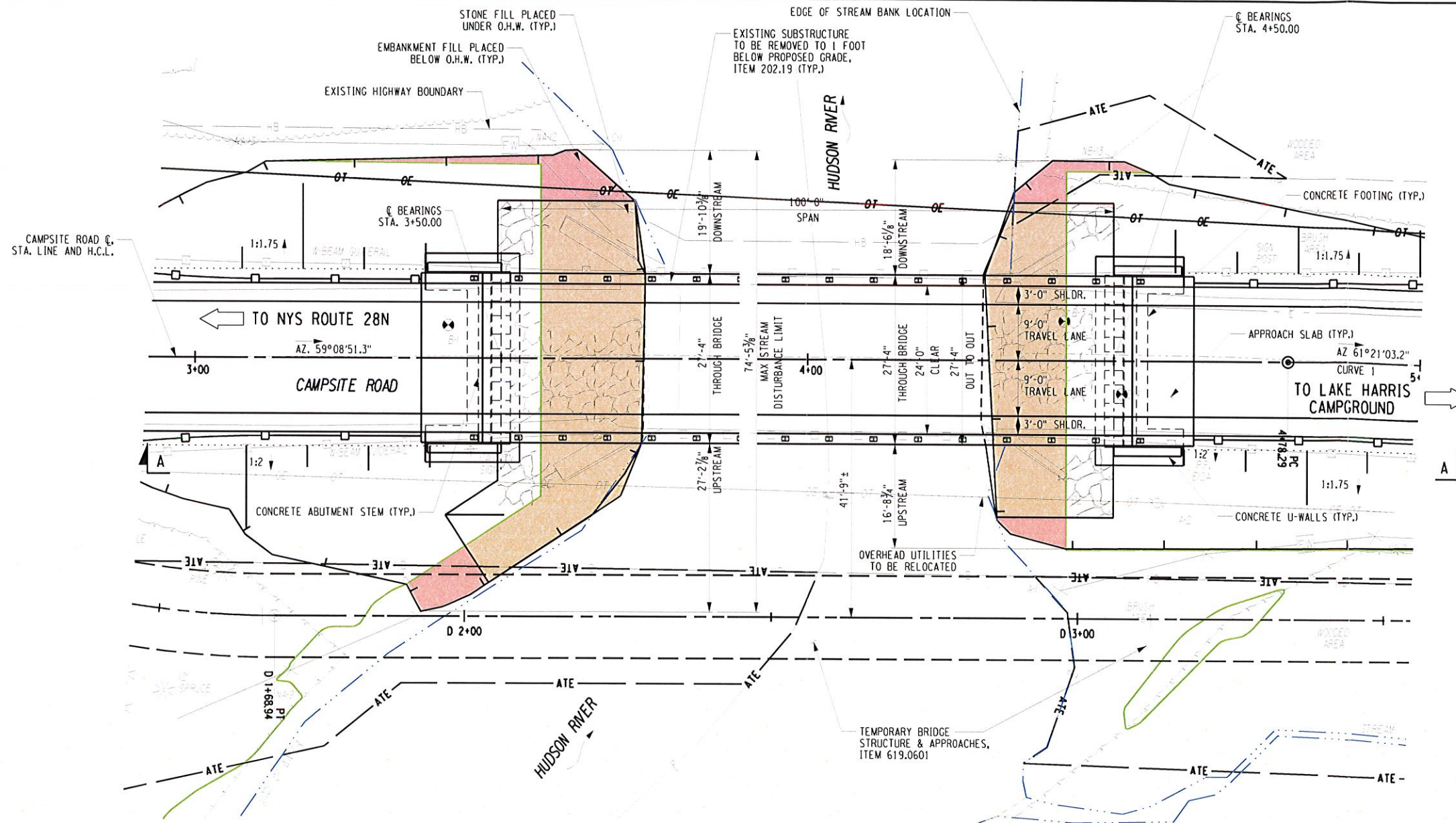

RECEIVED
 ENVIRONMENTAL PERMITS
 JAN 07 2019
 NYSDEC - REGION 5
 RAY BROOK

HYDRAULIC DATA		BASE FLOOD	DESIGN FLOOD
DRAINAGE AREA = 116 SQ. MI.			
FREQUENCY INTERVALS (YEARS)		100	50
PEAK DISCHARGE (CFS)		7680	6780
HIGH WATER ELEV. (FT)		1563.4	1562.7
FREEBOARD PROVIDED (FT)		EXIST 0.1 PROP. 1.3	0.7 2.0
AVG. VELOCITY @ STRUCTURE (FT/S)		9.92	8.85

LOAD RATING (LOAD FACTOR)		
INVENTORY	MS	TONS
OPERATING	MS	TONS

- TEMPORARY STRUCTURE NOTE**
- THE PROPOSED TEMPORARY STRUCTURE SHALL PROVIDE A MINIMUM CLEAR OPENING OF 78 FT. PERPENDICULAR TO THE FLOW WITH A MINIMUM ACCEPTABLE LOW BEAM ELEVATION OF 6465. A MINIMUM CLEAR WATERWAY AREA OF 1562.42 SF IS REQUIRED BELOW THE MINIMUM LOW BEAM ELEVATION.
 - FOR PURPOSES OF THIS STRUCTURE, MULTIPLE PIPES OR CELLS WILL NOT BE ACCEPTABLE.

- LEGEND:**
- EMBANKMENT AREA PLACED UNDER THE O.H.W. ELEV. OF 1560
 - HEAVY STONE FILLING AREA PLACED UNDER THE O.H.W. ELEV. OF 1560
 - O.H.W. 1560.00
 - APPROXIMATE FILL LINE
 - APPROXIMATE CUT LINE
 - BORING LOCATION & DESIGNATION
 - HEAVY STONE FILLING, ITEM 620.05

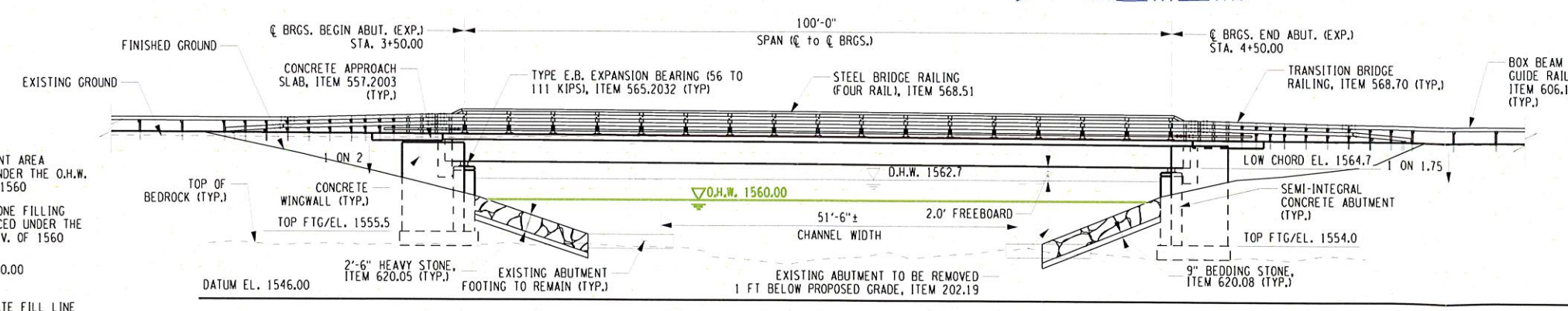
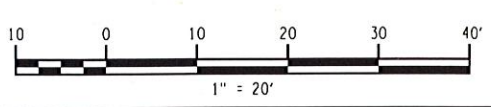

CURVE 1
 PC = STA. 4+78.29
 PT = STA. 5+01.37
 Δ = 2°12'11.92"
 R = 600.00'
 Dc = 9°32'57.47"
 L = 23.07
 T = 11.54'

AS-BUILT REVISIONS DESCRIPTION OF ALTERATIONS:	CAMPSITE ROAD OVER HUDSON RIVER BRIDGE REPLACEMENT PROJECT PIN 1760.68 BRIDGES BIN 3302040 TOWN OF NEWCOMB COUNTY: ESSEX REGION: 1	ALL DIMENSIONS IN FT UNLESS OTHERWISE NOTED	CONTRACT NUMBER DRAWING NO. ST-1 SHEET NO. 13 OF 38
GENERAL PLAN & ELEVATION		Department of Transportation	

IT IS A VIOLATION OF LAW FOR ANY PERSON, UNLESS THEY ARE ACTING UNDER THE DIRECTION OF A LICENSED PROFESSIONAL ENGINEER, ARCHITECT, LANDSCAPE ARCHITECT, OR LAND SURVEYOR, TO ALTER AN ITEM IN ANY WAY. IF AN ITEM BEARING THE STAMP OF A LICENSED PROFESSIONAL IS ALTERED, THE ALTERING ENGINEER, ARCHITECT, LANDSCAPE ARCHITECT, OR LAND SURVEYOR SHALL STAMP THE DOCUMENT AND INCLUDE THE NOTATION "ALTERED BY" FOLLOWED BY THEIR SIGNATURE, THE DATE OF SUCH ALTERATION, AND A SPECIFIC DESCRIPTION OF THE ALTERATION.



DEPARTMENT OF THE ARMY
U.S. Army Corps of Engineers, ATTN: CENAN-OP-RU
Upstate Regulatory Field Office
1 Buffington St., Building 10, 3rd Fl. North
Watervliet, New York 12189-4000

FEB 04 2019

Upstate New York Section

SUBJECT: Permit Application No. NAN-2018-01542-UDE
by Essex County Department of Public Works
Town of Newcomb, Essex County, New York

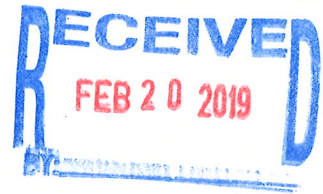

Chris Garrow, Superintendent
Essex County Department of Public Works
8053 U.S. Route 9
Elizabethtown, New York 12932

Dear Mr. Garrow:

This office has reviewed your Joint Application Form dated November 13, 2018, its attachments, and the additional information you provided on December 28, 2018, and January 18, 2019, including the drawings prepared by Creighton Manning Engineering, LLP, and the New York State Department of Transportation entitled "Campsite Road Over Hudson River, Bridge Replacement Project", with Drawing Nos. ST-1, ST-7, ST-8 and ST-26 dated January 18, 2019, and Drawing Nos. ST-3, ST-4 and ST-5 dated November 13, 2018. The submitted information describes a proposal that would consist of the following:

The discharge of fill material into waters of the United States to facilitate the replacement of a bridge carrying Campsite Road over the Hudson River. The existing bridge would be replaced on the same horizontal alignment with a bridge having a span of approximately 100 feet and an out to out width of 27'4".
Approximately 180 cubic yards of rock would be discharged into the river to provide scour protection at the new bridge. An on-site detour, which would result in temporary impacts to approximately 0.09 acre of wetlands, would be provided to maintain traffic during construction. Temporary cofferdams would be used to facilitate the accomplishment of the in-water work. All tree cutting and removal necessary to accomplish the authorized work shall only occur during the period from October 1 through March 31 in any year this verification is in effect.
Additional authorization shall be obtained to relocate the overhead utility lines in the project area.

Based upon the information provided, it appears that your proposed work may be authorized under Department of the Army nationwide general permit number: 3. The nationwide permits are prescribed as a Reissuance of Nationwide Permits in the Federal Register dated January 6, 2017 (82 FR 1860).

The work may be performed without further authorization from this office provided the activity complies with the terms and conditions of the Nationwide Permits

PLEASE USE THE ABOVE 18-CHARACTER FILE NUMBER ON ALL CORRESPONDENCE WITH THIS OFFICE

(NWP) and the permit conditions listed in Section B, No. 3, Section C, any applicable New York District regional conditions, and any applicable regional conditions added by the State of New York. Please note that NWP General Condition No. 12 requires the installation and maintenance of proper soil erosion and sediment controls during construction.

The 2017 Nationwide Permits, including their final regional conditions, water quality certifications, and coastal zone concurrence statements are available at:

<http://www.nan.usace.army.mil/Missions/Regulatory/Nationwide-Permits/>

Please review and familiarize yourself with all relevant terms and conditions of the nationwide permit prior to proceeding with your project, and subsequently ensure you adhere to all conditions through the duration of the project. If you do not have internet access and require a specific paper copy, please contact the undersigned to request one be mailed to you. Please be sure to have your permit application number readily available when you call.

This verification is valid until March 18, 2022, unless the nationwide permit is modified, reissued, or revoked. This verification will remain valid until March 18, 2022, if the activity complies with the terms of any subsequent modifications of the nationwide permit authorization. If the nationwide permits are suspended, revoked, or modified in such a way that the activity would no longer comply with the terms and conditions of a nationwide permit, and the proposed activity has commenced, or is under contract to commence, the permittee shall have 12 months from the date of such action to complete the activity.

Please note that this determination does not eliminate the need to obtain any other Federal, State, or local authorizations required by law for the above described work, including any required permit from the NYSDEC.

In order for us to better serve you, please complete our Customer Service Survey located at:

<http://www.nan.usace.army.mil/Missions/Regulatory/CustomerSurvey.aspx>

Any inquiries can be directed to the undersigned at (518) 266-6354.

Sincerely,

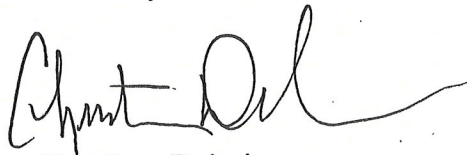

Christine Delorier
Senior Project Manager
Upstate New York Section

Enclosures

Cf: NYSDEC Region 5, Ray Brook (DEC #5-1538-00034/00004)
Town of Newcomb
A. Brown – Creighton Manning Engineering, LLP
P. Blakelock – NYSEG
D. McDermott – Frontier Communications

(This page intentionally left blank)

Appendix D
Soil Boring Logs

(This page intentionally left blank)

PROJECT: Bridge Replacement

DATE

START: 1/29/18

FINISH: 1/30/18

LOCATION: Campsite Road - Newcomb, NY

METHODS: Flush-Joint Steel Casing with

CLIENT: Creighton Manning Engineering

with ASTM D1586 and D2113 Sampling

JOB NUMBER: JB-17-5-557

SURFACE ELEVATION:

DRILL TYPE: CME 55 ATV Mounted Rig

CLASSIFICATION: E. Gravelle, PE

SAMPLE		BLOWS ON SAMPLER					CLASSIFICATION / OBSERVATIONS
DEPTH	#	6"	12"	18"	24"	N	
	1	19	20				±10" ASPHALT over FILL: Gray Crusher-Run STONE (MOIST, COMPACT)
				14	17	34	
5'	2	9	4				FILL: Brown Fine to Medium SAND, Little Gravel, trace coarse sand and silt, Cobble and Boulders noted to 9.5' depth (MOIST, LOOSE)
				4	5	8	
10'	3	15	5				Black Organic SILT and Fine SAND to Brown Fine SAND, trace silt (VERY MOIST TO WET, LOOSE)
				3	2	8	
15'	4	50/.0'				REF	Rock Surface at ±15.1' Depth Gray GRANITE, Very Hard, Sound, Bedded Becomes Thick Bedded to Massive
20'		Rock Core Run #1 16.0' to 20.4' Recovery = 98% RQD = 91%					
		Rock Core Run #2 20.4' to 25.4' Recovery = 96% RQD = 96%					
25'							Boring Ended at 25.4' Water in casing at 12.0' below grade in hour after completion of coring.

PROJECT: Bridge Replacement

DATE

START: 1/15/18

FINISH: 1/15/18

LOCATION: Campsite Road - Newcomb, NY

METHODS: 3-1/4" I.D. Hollow Stem Augers

CLIENT: Creighton Manning Engineering

with ASTM D1586 Sampling

JOB NUMBER: JB-17-5-557

SURFACE ELEVATION:

DRILL TYPE: CME 45 Trailer Mounted Rig

CLASSIFICATION: E. Gravelle, PE

SAMPLE		BLOWS ON SAMPLER					CLASSIFICATION / OBSERVATIONS	
DEPTH	#	6"	12"	18"	24"	N		
5'	1	21	50/.3'			REF	±7" ASPHALT over FILL: Gray Crusher-Run Stone to Brown Fine to Coarse SAND and GRAVEL, trace silt Black Decomposed ASPHALT Brown Fine to Coarse SAND, Some Gravel, Little Silt, Cobbles and Boulders noted Similar	
	2	50/.3'				REF		
	3	7	7					
	4	5	4		6	4		13
	5				5	12		9
10'	5	18	8				Similar	
					6	6		14
15'	6	50/.2'				REF	(MOIST, VERY COMPACT TO LOOSE) Brown Fine to Medium SAND, trace silt (WET)	
20'							Boring Ended at 16.9' with Auger Refusal Groundwater in augers at 13.1' below grade at completion of drilling and sampling.	
25'								

PROJECT: Bridge Replacement

DATE

START: 1/30/18

FINISH: 1/31/18

LOCATION: Campsite Road - Newcomb, NY

METHODS: Flush-Joint Steel Casing with

CLIENT: Creighton Manning Engineering

with ASTM D1586 and D2113 Sampling

JOB NUMBER: JB-17-5-557

SURFACE ELEVATION:

DRILL TYPE: CME 55 ATV Mounted Rig

CLASSIFICATION: E. Gravelle, PE

SAMPLE		BLOWS ON SAMPLER					CLASSIFICATION / OBSERVATIONS
DEPTH	#	6"	12"	18"	24"	N	
	1	75	65				± 8" ASPHALT over FILL: Brown Fine to Medium SAND, trace gravel and silt
	2	15	18				
5'	3	3	22				Gray Crusher-Run Stone at 3.0' to 3.5', then Brown Fine to Coarse SAND, Some Gravel, trace silt, Cobble and Boulders noted, Little Asphalt in Sample #2
				50/.4'		REF	
10'	4	7	26				(MOIST, VERY COMPACT TO COMPACT) POSSIBLE FILL: Brown Fine to Coarse SAND and GRAVEL, trace silt
				8	5	34	
15'	5	3	5				(WET, FIRM) Black Organic SILT and Fine SAND (WET) Rock Surface at ± 16.6' Depth
				7	50/.2'	12	
20'	Rock Core Run #1 17.0' to 22.0' Recovery = 96% RQD = 96%						Gray GRANITE, Very Hard, Sound, Massive to Bedded
	Rock Core Run #2 22.0' to 27.0' Recovery = 102% RQD = 58%						
25'							Becomes Thick to Thin Bedded at 25.5' becomes Highly Fractured
Boring Ended at 27.0'							Water in casing at 13.3' below grade one hour after completion of coring.